

SHIKA EXPRESS - PHYSICS

Version 2.0 TZ

HANDS-ON ACTIVITIES COMPANION GUIDE
TANZANIA

TEACHER'S GUIDE

May 6, 2018

Questions or Comments?

Thank you for using the *Shika Express - Physics* manual! If you have any questions, comments, or would like to request a copy of this manual, please use the contact information given below.

Shika na Mikono Primary Contact (shika.mikono.tz@gmail.com)

You may also contact any of the current members of the Shika na Mikono team directly using the following contact information.

Ed. 2017

Kyle Golden (kylegldn@gmail.com)
Kayla Huffman (kaylarhuffman@gmail.com)
Iain Laufer (iainlaufer360@gmail.com)
Mara McKown (marasmckown@gmail.com)
Brandi Rajala (brajala@mtu.edu)
Emily Slater (eslater6@gatech.edu)

Ed. 2016

Kalvin Croto (kmcroto@gmail.com)
Marguerite Daw (margueritedaw@gmail.com)
Katharine Kobylt (kat.kobylt@gmail.com)
Jonathan McClure (jonathanmcclure37@gmail.com)
Cailin McLaughlin (cailin_mac@yahoo.com)
Paige Van de Vuurst (paigevandevurrst29@gmail.com)

To download a digital version of this manual, please visit the [digital download page](http://pctanzania.org/shika) at the following address: <http://pctanzania.org/shika>

Feedback and requests for revisions to the content of any of the manuals can be made using the primary contact information above, or by visiting the [Shikamikonotz Project Page](https://github.com/shikamikonotz/) at GitHub: <https://github.com/shikamikonotz/>

Contents

I	Laboratory Development	4
1	Starting School Laboratories	5
2	Specific Technical Needs of a School Physics Laboratory	6
3	Improving an Existing School Laboratory	7
4	Salvaging Old Equipment - Voltmeters, Ammeters, Galvanometers	9
II	Laboratory Safety	10
5	Guidelines for Laboratory Safety	11
6	First Aid	15
7	Dangerous Techniques	17
III	Laboratory Management	18
8	Classroom Management in the Laboratory	19
9	Routine Cleanup and Upkeep	21
	Hands-On Activities	22
10	Physics Activities for Form I	23
10.1	Introduction to Physics	23
10.2	Introduction to Laboratory Practice	26
10.3	Measurement and Density/Relative Density	31
10.4	Force	35
10.5	Archimedes' Principle and the Law of Flotation	37
10.6	Structure and Properties of Matter	40
10.7	Pressure	47
10.8	Work, Energy and Power	52
10.9	Light	54
11	Physics Activities for Form II	58
11.1	Static Electricity	58
11.2	Current Electricity	61
11.3	Magnetism	64
11.4	Forces in Equilibrium	66
11.5	Simple Machines	69
11.6	Motion in a Straight Line	73
11.7	Newton's Laws of Motion	75
11.8	Temperature	79
11.9	Sustainable Energy Sources	80
12	Physics Activities for Form III	81
12.1	Friction	81
12.2	Light	84
12.3	Optical Instruments	90
12.4	Thermal Expansion	91
12.5	Transfer of Thermal Energy	96
12.6	Measurement of Thermal Energy	100

12.7 Vapour and Humidity	104
12.8 Current Electricity	105
13 Physics Activities for Form IV	109
13.1 Waves	109
13.2 Electromagnetism	119
13.3 Electronics	123
13.4 Elementary Astronomy	125
Materials and Equipment	127
14 Local Materials List	128
15 Low Tech Microscopy	139
16 Storage of Materials	142
17 Pastes and Modeling Materials	143
Appendix	145
A Activity Template	145

Part I

Laboratory Development

Starting School Laboratories

A science laboratory is any place where students learn science with their hands. It might be a room, or just a box. The goal is to develop a space that facilitates hands-on learning.

1.1 Benefits of a School Laboratory

There are many benefits of having a laboratory:

- Students learn more and better science
- Students get more excited about science class
- Students have to go to the lab for class, thus eliminating those too lazy to walk over
- Practical exams are easier than the alternative-to-practical exams
- Everyone thinks practicals are important, and that science without practicals is silly.

1.2 Challenges of a School Laboratory

There are some challenges with having a laboratory:

- They are places where people can get hurt
This is true. Please see the sections on [Classroom Management in the Laboratory](#) (p. 19) and [Laboratory Safety](#) (p. 11) to mitigate this risk.
- Many teachers do not know how to use a laboratory
Then use the lab to teach them how to use it, thus spreading skills.
- Laboratories are far too expensive for poor schools to build and stock
This is simply incorrect. Any room will work for a lab, and any school can afford the materials required to stock it. The rest of this book is dedicated to this point.

So you want to build a laboratory?

1.3 Step one: Location

A permanent location is obviously preferable. If your school has an extra classroom, great. The only requirements of a potential room are that it be well ventilated (have windows that either open or lack glass altogether) and be secure: bars in the windows, a sturdy door, and a lock. If you plan to put fancy equipment in your lab, remember that hack saw blades are cheap and that the latch through which many pad locks pass can be cut quickly regardless of the lock it holds. But if you are just starting, there will probably not be any fancy equipment; a simple lock is enough to keep overly excited students from conducting unsupervised experiments.

If there is no extra space at all, the lab can live in a few buckets and be deployed in a classroom during class time. “There is no lab room,” is no excuse for not having a lab.

1.4 Step two: Funding

Yes, some is required. But the amount is surprisingly little – in most countries a single month of a teacher’s salary is enough to furnish a basic laboratory. Almost every school can find the amount required to get started, and if not the community certainly can. A single cow in most countries would pay for a basic laboratory many times over. A cow is valuable. So is science education.

We encourage you to resist the temptation to ask people outside of the school community or school system to pay for the lab. There is simply no need to encourage that sort of dependence; this can be done locally, and it should be.

Specific Technical Needs of a School Physics Laboratory

A basic physics laboratory should allow for the following investigations:

- Measuring volume, mass, and density of liquids and solid objects
- Measuring time, velocity, acceleration
- Gravitational acceleration, force, and friction
- Mechanical tools (levers, pulleys, etc.)
- Simple harmonic motion (pendulum, spring)
- Temperature, heat capacity, and heat transfer (conduction, convection, radiation)
- Waves (including water and sound)
- Optical experiments (reflection, refraction, diffraction)
- Electromagnetic experiments (conductivity, magnetic field lines, induction, motors, electrical generation)
- Simple circuits (including resistors, capacitors, and switches)

Key materials are:

- A low cost balance (digital)
- Tools for measuring volume
- Containers, misc. objects, bottles, etc.
- Stopwatches
- Heat sources
- Thermometers
- String, springs, wire
- Water, oil, sand, rocks
- Mirrors, lenses, glass blocks, diffracting surfaces
- Magnets
- Power supply (e.g. batteries)
- Inexpensive multimeters or locally made galvanometers
- Electrical components

Improving an Existing School Laboratory

If there is already a laboratory at your school, the immediate tasks are to see what it has, make it safe, get it organized, make repairs, and ensure smart use with sound management.

3.1 Inventory

- Making a list of what and how much of everything is in your lab is easy, if time consuming. Difficulties arise when you find apparatus you have never seen before, or containers of chemicals without labels.
- Unknown apparatus are not harmful nor useful until you know what they do. Ask around.

3.2 Organize

Have enough space

The key to organization is having enough space. Usually, this means building shelves. In the long term, find a carpenter to build good shelves. In the short term, boards and bricks, scrap materials, chairs, anything to provide sturdy and horizontal storage space. It should be possible to read the label of every chemical, and to see each piece of equipment.

Apparatus

- Arrange apparatus neatly so it is easy to find each piece.
- Put similar things together.
- Beakers can be nested like Russian dolls.

Make a map and ledger

- Once you have labeled and organized everything in a lab, draw a map.
- Sketch the layout of your laboratory and label the benches and shelves.
- In a ledger or notebook, write down what you have and the quantity. For example, Bench 6 contains 20 test tubes, 3 test tube holders, and 4 aluminum pots.

This way, when you need something specific, you can find it easily. Further, this helps other teachers – especially new ones – better use the lab. Finally, having a continuously updated inventory will let you know what materials need to be replaced or are in short supply. Proper inventories are a critical part of maintaining a laboratory, and they really simplify things around exam time.

3.3 Repair/Improve

Once the lab is organized, it is easy to find small improvements. Here are some ideas:

Build more shelves

You really cannot have too many.

Check voltage and current meters

Voltmeters, ammeters and galvanometers often get discarded or unused despite still being able to function sufficiently for use during demonstrations and practicals. Before getting rid of these meters, see the section on [Checking Voltmeters and Ammeters/Galvanometers](#) (p. 9).

Identify key apparatus needs

Sometimes a few pieces of apparatus can be very enabling, like enough measuring cylinders, for example. Buy plastic!

3.4 What next?

Once the lab is safe and organized, develop a system for keeping it that way. Consider the advice in [Routine Cleanup and Upkeep](#) (p. 21). Make sure students and other teachers in involved.

Then, start using the lab! Every class can be a lab class. That is the whole point.

Salvaging Old Equipment - Voltmeters, Ammeters, Galvanometers

4.1 Checking Voltmeters and Ammeters/Galvanometers

Needed: Meters to check, a couple wires, some resistors and a fresh battery.

Important note: There is a wrong way to hook up the meter. The needle will try to deflect down because negative and positive are swapped. If the reading is zero, make sure that you try the opposite connection to be sure.

4.1.1 Voltmeters

Hook up the voltmeter across the battery. The battery is probably 1.5 V, but do not worry if you see 1.1, 1.2, even if using a brand new battery. Try not to use a battery that reads much below 1 V on several different meters.

Unuseable Voltmeters

- Totally dead, no deflection of the needle
- Voltage reading jumps excessively. Ensure that the connections are solid and test again.
- Measured voltage is totally wrong, not close to 1.5 V

Useable Voltmeters

Read a voltage close to 1.5. If the voltage is not 1.5 exactly, the voltmeter is probably working fine, and the battery is just off a bit.

4.1.2 Ammeters

Hook up the ammeter in series with a resistor. Because you do not necessarily know the condition of the ammeter before testing, be sure to have several different resistors on hand. An ammeter may appear not to work if resistance is too high or too low. Start testing different ammeters.

Unuseable Ammeters

- Totally dead, no deflection of the needle
- Current reading jumps excessively (but check connections)
- Totally wrong, reads much different from other ammeters

Useable Ammeters

Read a current similar to other ammeters. Hard to say exactly what current, but feel free to calculate based on your resistor using $V = IR$, although do not forget that there is some internal resistance r of battery, so $V = I(R + r)$. The resistance of the resistor is usually coded on the resistor in a series in stripes – see the instructions under [Resistors](#) (p. 134).

Tip: You can hold the wires onto the battery with your fingers; the current is far too low to shock you.

Other: Now that you have tested to see if your voltmeters and ammeters work, you can feel free to check all of them for accuracy, by calculating expected values and comparing between meters. Most practicals will still work alright with “somewhat” accurate meters, and most meters are either fine, or broken.

Part II

Laboratory Safety

Guidelines for Laboratory Safety

There is no excuse for laboratory accidents. Students and teachers get hurt when they do something dangerous or when they are careless. If you do not know how to use a substance or a tool safely, do not use it. If your students do not know how to use a chemical or a tool safely, do not let them use it until they do. Adopt a zero tolerance policy towards truly unsafe behavior (running, fighting, throwing objects, etc.) – first infraction gets students kicked out of class for the day. Explain the error to everyone to make sure that it is never repeated. If the same student errs again, expel him for longer. Make it clear that you will not tolerate unsafe behavior.

Remember, the teacher is responsible for everything that happens in the lab. If a student is hurt the teacher is to blame. Either the teacher did not understand the danger present, did not adequately prepare the laboratory or the lesson, did not adequately train the student in safe behavior, or did not offer adequate supervision. As a teacher, you must know exactly the hazards of your chemicals, tools, and apparatus. Explain these hazards clearly and concisely to your students before they touch anything.

The following rules are for everyone in the lab to follow – students, teachers, and visitors alike. We recommend painting them directly on the wall as most paper signs eventually fall down.

5.1 Basic Lab Rules

1. Wear proper clothes. For every practical, wear shoes. Sandals are not acceptable lab ware. If you are pouring concentrated chemicals, you need to wear safety goggles.
2. Nothing enters the mouth in the lab. This means no eating, no drinking, and no mouth pipetting.
3. Follow the instructions from the teacher. Obey commands immediately. Only mix chemicals as instructed.
4. If you do not know how to do something or what to do, ask the teacher.

In addition to these rules, we recommend a variety of guidelines for teachers and lab managers to keep the lab a safe place.

5.2 Specific Guidelines to Reduce Risk

1. Never use the following chemicals:
 - 1.1. Organic liquids, including:
 - 1.1.1. Benzene (C_6H_6)
 - 1.1.2. Chlorobenzene (C_6H_5Cl)
 - 1.1.3. Dichloromethane (CH_2Cl_2)
 - 1.1.4. Tetrachloromethane/carbon tetrachloride (CCl_4)
 - 1.1.5. Trichloroethane (CH_3CCl_3)
 - 1.1.6. Trichloromethane/chloroform ($CHCl_3$)
 - 1.2. Anything containing mercury:
 - 1.2.1. Mercury metal (Hg)
 - 1.2.2. Mercurous/mercuric chloride ($HgCl/HgCl_2$)
 - 1.2.3. Million's Reagent ($Hg + HNO_3$)
 - 1.2.4. Nestler's Reagent ($HgCl_2 +$ others)

2. Do not make hazardous substances
 - 2.1. Chlorine gas - electrolysis of chloride salts, oxidation of chloride salts or hydrochloric acid by oxidizing agents such as bleach or potassium permanganate
 - 2.2. Chloroamines - ammonia with bleach. People have died mixing ammonia and bleach together when mixing cleaning agents.
 - 2.3. Hydrogen cyanide - cyanide salts, including ferro- and ferri-cyanide, with acids.
3. Avoid hazardous substances
 - 3.1. If you have a choice, use non-poisonous substances. To be a good teacher, the only poisons that you have to use are those required by the national exams. For all other activities, use less dangerous substances.
 - 3.2. Only give students small quantities of required poisons.
 - 3.3. For advice on handling the various required poisons, see Laboratory Management: Dangerous Chemicals.
4. Avoid explosions
 - 4.1. Never heat ammonium nitrate.
 - 4.2. Never heat nitrates in the presence of anything that burns.
 - 4.3. Never heat a closed container.
 - 4.4. If performing a distillation or other experiment with boiling or hot gases, make sure that there is always an unobstructed path for gases to escape.
5. Avoid fires
 - 5.1. Be careful!
 - 5.2. Keep all flammable materials away from flames. Never have the following very flammable chemicals in the same room as fire: propanone (acetone), ethyl ethanoate (ethyl acetate), diethyl ether.
 - 5.3. Keep stoves clean and in good working order. Do not douse stoves with water to extinguish them because the metal will corrode much faster (think kinetics). There is never a need for this. If the stove does not extinguish on its own, you should repair it so it does.
 - 5.4. Only use the appropriate fuel for a given stove. For example, never put petrol in a kerosene stove.
6. Avoid cuts
 - 6.1. Only use sharp tools when required, and design activities to minimize use of sharp tools.
 - 6.2. Keep sharp tools sharp. The only thing more dangerous than cutting with a sharp knife is cutting with a dull one.
 - 6.3. Use the right tool for cutting.
 - 6.4. Use as little glass as possible.
 - 6.5. Do not use broken glass apparatus. The last thing you want to deal with during a practical is serious bleeding. It is tempting to keep using that flask with the jagged top. Do not. Do not let anyone else use it either – break it the rest of the way.
 - 6.6. Dispose of sharp trash (glass shards, syringe needles) in a safe place, like a deep pit latrine.
7. Avoid eye injuries
 - 7.1. Students should wear goggles during any activity with a risk of eye injury. See the Materials: Apparatus section for suggestions on goggles. If you do not have the goggles necessary to make an experiment safe, do not do the experiment.
 - 7.2. Keep test tubes pointed away from people during heating or reactions. Never look down a test tube while using it.

- 7.3. Never wear contact lenses in the laboratory. They have this way of trapping harmful chemicals behind them, magnifying the damage. Besides, glasses offer decent (though incomplete) protection on their own.
8. Avoid chemical spills
 - 8.1. Teach students that if they get chemicals on their hands, they should wash them off immediately, without asking for permission first. Some students have been taught to wait for a teacher's permission before doing anything in the lab, even if concentrated acid is burning their hands. On the first day, give them permission to wash their hands if they ever spill chemicals on them.
 - 8.2. Also, teach students to tell you immediately when chemicals are spilled. Sometimes they hide chemical spills for fear of punishment. Do not punish them for spills - legitimate accidents happen. Do punish them for unsafe behavior of any kind, even if it does not result in an accident.
9. Use adequate protection with hazardous chemicals.
 - 9.1. Wear eye protection (see above). Find goggles or things that will substitute.
 - 9.2. Tie a cloth over your face when using concentrated ammonia or HCl. For the latter chemical, see below.
 - 9.3. Sulfuric Acid, H_2SO_4
 - 9.3.1. There is never any reason to ever use fully concentrated (18 M) sulfuric acid.
 - 9.3.2. For qualitative analysis, 5 M H_2SO_4 is sufficient for "concentrated sulfuric acid."
 - 9.3.3. Do not buy 18 M sulfuric acid. Battery acid will suffice for qualitative analysis and is a much safer (if still quite dangerous) source of sulfuric acid.
 - 9.3.4. If you already have 18 M sulfuric acid in your lab, just leave it. Battery acid is so cheap you can afford to get as much as you need.
 - 9.4. Hydrochloric acid, HCl
 - 9.4.1. Hydrochloric acid is never required.
 - 9.4.2. Do not buy concentrated hydrochloric acid. Use battery acid for all of its strong acid applications.
 - 9.4.3. When you need the reducing properties of HCl, for the precipitation of sulfur from thio-sulfate in kinetics experiments for example, make a solution with the proper molarity of chloride and H^+ by dissolving sodium chloride in battery acid and diluting with water.
 - 9.5. Nitric acid, HNO_3
 - 9.5.1. The only time nitric acid is required is to dissolve certain carbonates in qualitative analysis. The first time you need nitric acid, prepare a large volume of dilute acid (e.g. 2.5 L) so that you do not need to handle the concentrated acid again.
 - 9.5.2. If many schools share a single bottle of concentrated acid, they should dilute it at a central location and transport only the dilute acid.
 - 9.5.3. Teach qualitative analysis of insoluble carbonates using copper, iron, or zinc carbonate – these will dissolve in dilute sulfuric acid.
10. Avoid mouth pipetting
 - 10.1. Never do it!
 - 10.2. This is a dangerous activity prohibited in every modern science laboratory.
 - 10.3. Use rubber pipette filling bulbs or plastic syringes.
 - 10.4. For more explanation, see Mouth pipetting in [Dangerous Techniques](#) (p. 17).
11. Be prepared
 - 11.1. Set aside a bucket of water for first aid.
 - 11.2. It should not be used for anything else.
 - 11.3. Have materials to fight fires and know how to use them.

11.4. A bucket of sand will work for any lab fire, is available to every school, and can be used by anyone.

12. Use good habits

12.1. Hand washing

12.1.1. Students should wash their hands every time they leave the lab.

12.1.2. Always have water and soap available, ideally in buckets on a desk near the door.

12.1.3. Even if students do not touch any chemicals when they are in the lab, they should still wash their hands.

12.2. Clean all benches and chemicals

12.2.1. Stray chemicals and contaminated apparatus has the potential for danger.

12.2.2. Make sure students do not leave stray pieces of paper.

12.2.3. Ensure all students clean the apparatus they use immediately after use.

12.2.4. Have students to clean apparatus prior to use. It is not always possible to trust the students washed the apparatus after their last use.

12.3. Tasting chemicals

12.3.1. Students should never eat anything in the lab. Ever.

12.3.2. Barium nitrate looks just like sodium chloride. Lead carbonate looks like starch.

12.3.3. Do not bring food into the lab.

12.3.4. If you use domestic reagents (vinegar, salt, baking soda, etc.) in the lab, label them and leave them in the lab.

12.4. Smelling chemicals

12.4.1. Be aware that many chemicals give off fumes that can produce obnoxious odors or be irritating to the respiratory system.

12.4.2. Practicals involving nitrates, chlorides, ammonium compounds, and some sulphates produce harmful gases.

12.4.3. Open the lab windows to maximize airflow.

12.4.4. Kerosene stoves also produce noxious fumes - it is much better to use motopoa.

12.4.5. If students feel dizzy or sick from the fumes, let them go outside to recover.

12.4.6. Many lab reagents – ammonia, hydrochloric acid, nitric acid, ethanoic (acetic) acid – can cause serious damage if inhaled directly.

12.5. Keep bottles and other apparatus away from the edge of the table. Twenty centimeters is a good rule.

12.6. Cap reagent bottles when they are not in use.

12.7. Do not do things you do not want your students to do. They are always watching, always learning.

First Aid

In spite of taking all necessary precautions to avoid dangerous situations in the laboratory, emergencies may still arise which require the immediate use of First Aid techniques. Listed below are various types of possible emergencies, as well as some immediate treatment guidelines to follow until professional medical attention may be given to the victim.

Cuts

1. Immediately wash cuts with lots of water to minimize chemicals entering the blood stream.
2. Then wash with soap to kill any bacteria that may have entered the wound.
3. To stop bleeding, apply pressure to the cut and raise it above the heart. If the victim is unable to apply pressure him/herself, remember to put something (gloves, a plastic bag, etc.) between your skin and their blood.
4. If the cut is deep (might require stitches) seek medical attention. Make sure that the doctor sees how deep the wound really is – you might do such a good job cleaning the cut that the doctor will not understand how serious it is.

Eyes

1. If chemicals get in the eye, immediately wash with lots of water.
2. Keep washing for fifteen minutes.
3. Remind the victim that fifteen minutes is a short time compared to blindness for the rest of life. Even in the middle of a national exam.

First and Second Degree Burns

1. Skin red or blistered but no black char.
2. Immediately apply water.
3. Continue to keep the damaged skin in contact with water for 5-15 minutes, depending on the severity of the burn.

Third Degree Burns

1. Skin is charred; there may be no pain.
2. Do not apply water.
3. Do not apply oil.
4. Do not removed fused clothing.
5. Cover the burn with a clean cloth and go to a hospital.
6. Ensure that the victim drinks plenty of water (one or more liters) to prevent dehydration.

Chemical Burns

1. Treat chemical burns by neutralizing the chemical.
2. For acid burns, immediately apply a dilute solution of a weak base (e.g. sodium hydrogen carbonate).
3. For base burns, immediately apply a dilute solution of a weak acid (e.g. citric acid, ethanoic acid).
Have these solutions prepared and waiting in bottles in the lab.

Ingestion

1. If a student ingests (eats or drinks) the following, induce vomiting.
 - 1.1. Barium (chloride, hydroxide, or nitrate)
 - 1.2. Lead (carbonate, chloride, nitrate, oxide)
 - 1.3. Silver (nitrate)
 - 1.4. Potassium hexacyanoferrate (ferr[i/o]cyanide)
 - 1.5. Ammonium ethandioate (oxylate)
 - 1.6. Anything with mercury (see list above), but mercury compounds should just never be used.
2. To induce vomiting:
 - 2.1. Have the student put fingers into his/her throat
 - 2.2. Have the student drink a strong solution of salt water (use food salt, not lab chemicals)
3. Do not induce vomiting if a student ingests any organic chemical, acid, base, or strong oxidizing agent.
 - 3.1. These chemicals do most of their damage to the esophagus and the only thing worse than passing once is passing twice.
 - 3.2. Organic chemicals may be aspirated into the lungs if vomited, causing a sometimes fatal pneumonia-like condition.

Fainting

1. If a student passes out (faints), feels dizzy, has a headache, etc., move him/her outside until fully recovered.
2. Check unconscious students for breath and a pulse.
3. Perform CPR if necessary and you know how.
4. Generally, these ailments suggest that harmful gases are present in the lab – find out what is producing them and stop it. Kerosene stoves, for example, may emit enough fumes to have this effect.
5. See Sources of Heat in the Materials section for alternatives.
6. Chemicals reacting in drain pipes can also emit harmful gases. See Waste Disposal.

Electrocution

 – If someone is being electrocuted (their body is in contact with a live wire)

1. First disconnect the power source. Turn off the switch or disconnect the batteries.
2. If that is not possible, use a non-conducting object, like a wood stick or branch, to move them away from the source of electricity.
3. Unless there is a lot of water around, the sole of your shoe is non-conducting.

Seizure

1. If a student experiences a seizure, move everything away from him/her and then let the body finish moving on its own.

Dangerous Techniques

Some common laboratory techniques are actually quite dangerous. Identify practices in your school that seem likely to cause harm and devise safer alternatives. Below are some examples of techniques often performed in the laboratory that can easily bring harm and alternative methods to do the same thing more safely.

Mouth Pipetting

Many schools use pipettes for titrations. Many students use their mouths to fill these pipettes. We strongly discourage this practice. The solutions used in ordinary acid-base titrations are not particularly dangerous. A little 0.1M NaOH in the mouth does not merit a trip to the hospital. Nevertheless, there are two pressing safety issues.

1. First, there are often other solutions present on the same benches the qualitative analysis test reagents for example that can kill if consumed. It seems like it would be a rare event for a student to mix up the bottles, but in the panic of the exam anything is possible.
2. Second, safety issue applies to the best students, those that continue on to more advanced levels. High level secondary and university students must measure volumes of the size fit for pipettes for chemicals that under no circumstances should be mouth pipetted. If a student is trained in mouth pipetting, she will continue with this habit in advanced level, especially in a moment of frustration when a pipette filling bulb seems defective, or if the school has not taught her how to use them, or if they are not supplied. Students have died in many countries from mouth pipetting toxins.

Fortunately, there is no reason to ever use a pipette in secondary school, even if rubber-filling bulbs are present. *Disposable plastic syringes are in every way superior to pipettes for the needs of students.*

- They have no risk of chemical ingestion.
- They are more accurate plastic is much easier to make standard size than glass; the pipettes available generally vary from their true volume, but all the syringes of the same model and maker are exactly the same volume.
- Plastic syringes are easier to use
- They are faster to use
- They are much more durable
- When they do break they make no dangerous shards
- They are much less expensive, by about an order of magnitude

Schools all over are already substituting plastic syringes for glass pipettes.

Shaking Separatory Funnels

Separatory funnels are useful for separating immiscible liquids. They are also made of glass, very smooth, and prone to slipping out of students' hands. The liquids often used in these funnels can be quite harmful and no one wants them splashed along with glass shards on the floor. Much better is to add the mixture to a plastic water bottle, cap it tightly, and shake. After shaking, transfer the contents of the bottle into a narrow beaker. Either layer can be efficiently removed with a plastic syringe.

There are some cases where a separatory funnel remains essential. For secondary school, however, simply design experiments that use other equipment - and less harmful chemicals.

Looking Down into Test Tubes

May blind.

Part III

Laboratory Management

Classroom Management in the Laboratory

In addition to the guidelines recommended in the [Laboratory Safety](#) section, we recommend the following strategies to keep lab work safe, productive, and efficient.

Set lab rules

Before the first practical of the year, hold a short session to teach lab rules and lab first aid. Try to set a few clear, basic rules (like the four proposed in the Laboratory Safety section) instead of a long list of rules. Post these rules in the lab, and be consistent and strict in enforcing them with students and teachers.

Train students in basic techniques

For students just beginning laboratory-based education, you can probably teach each specific skill one at a time as they come up in experiments. For more advanced students, especially when they have different backgrounds in terms of laboratory experience, it is wise to spend several sessions practicing basic techniques (e.g. titrations for chemistry, using the galvanometer for physics, etc).

Have students copy the lab instructions before entering the lab

Do not let them into the lab unless they can show you their copy of the procedure, etc. Have a class dedicated to explaining the practical activity before the actual session. Bring a demo apparatus into the classroom.

Demonstrate procedures at the beginning

Do not assume that students know how to use a syringe or measure an object with calipers. If there are many new procedures, hold a special session before the practical to teach them the procedures. For titration, for example, hold a practice session in using burettes and syringes with water and food coloring. For food tests, explain and demonstrate each step to the students before holding a practical. It will save you a lot of trouble during the actual practical.

Have enough materials available

Always prepare 25-50 percent more reagent than you think you will need. Also have spare apparatus in case they fail in use. For example with physics, have extra springs, resistors, weights, etc. That said; do not make all of what you prepare immediately available to the students. As with sugar and salt, an obvious surplus increases consumption. If there is a definite scarcity of resources, it may be necessary to distribute the exact volumes necessary to each student. If you are doing this, make sure students understand that there is no more. In an exam, you might take unique objects, such as ID cards, to ensure each student receives her/his allotment only once.

Have enough bottles of reagent available

Even if only a small quantity of a reagent is needed, divide it into several bottles and put a bottle on each bench. If the volume is sufficiently small, distribute the chemical in plastic syringes. Do not use syringes for concentrated acids or bases because these chemicals can degrade the rubber in the syringe, there is a risk of the syringe jamming and the student squirting chemicals into eyes. The waiting caused by shared bottles leads to frustration and quarrels between groups. The last thing you want are students wandering around the lab and crowding to get chemicals.

Designate fetchers

If students must share a single material source, designate students to fetch materials. If a reagent needs to be shared among many students, explain this at the beginning, and have them come to the front of the room to get it rather than carrying it to their benches. This will help to avoid arguments and confusion over where the reagent is. If the students are in groups, have each group appoint one student to be in charge of fetching that chemical. However, it is much better to have the reagent available for each group at their workplace.

Teach students to clean up before they leave

This will save you a lot of time in preparing and cleaning the lab and it is just a good habit. Do not let students leave the lab until their glassware is clean and the bench is free of mystery salts and scraps of paper. If they do, consider not letting them in for the next practical. This might take assigned seats if you have many students. When they perform this clean up, make sure they follow whatever guidelines you have set for proper waste disposal.

Allow more time than you think you will need

What seems like a half hour experiment to you may take an hour for your students. Add fifteen minutes to a half hour more than you think will be necessary. If you finish early, you can have them clean up and then do a bonus demonstration.

Know the laboratory policies at the school

What is the policy on replacing broken equipment at the school? As a teacher, you need to know what you are going to do when the student drops an expensive piece of glassware. It is no fun to make up procedure while a student is in tears. What criteria will you use to determine if the student is “at fault?” Of course, this is less of an issue if you do not use glass apparatus.

Routine Cleanup and Upkeep

Like gardens and children, laboratories require constant attention. The Second Law of Thermodynamics does not sleep. The following advice should keep you on the winning side of the struggle against entropy.

Things to do immediately

- Remove broken glass from the floor. Use tools, like pieces of cardboard, not fingers!
- Neutralize and wash up chemical spills
- Replace chemical labels that have fallen off

The person who made the mess should clean it up. Make sure they know how before they are in a position to make a mess. If they are unable (e.g. hurt), have someone else do it. Review the incident with everyone present focusing on how to prevent similar accidents in the future. Avoid blaming other people – as the supervisor the accident is your fault; either you did not train someone well enough or your supervision of their behavior/technique was inadequate.

Things to do right after every lab use

- Return stock containers of chemicals to the store area. Only teachers should move glass bottles of corrosive or toxic chemicals. Remember to carry these with two hands!
- Transfer waste, including chemicals to be reused, into suitable storage containers
- Return apparatus to their proper places
- Put broken apparatus in a special place
- Wash off all benches / tables

The people who used the lab should do these things. If it is a lab class, the students should clean up the lab in that class period. If it is a group of teachers preparing experiments, the teachers should clean up their mess. Mess tends to grow with time, and no one wants to clean up someone else's mess.

Things to do either right after lab use or later that same day

- Transfer chemicals to be reused into more permanent and well labeled storage containers.
- Process all waste for disposal.
- Remove all trash from the laboratory.

If done right after lab use, those who used the lab should do this work. If the work is done later anyone can take out the trash but waste should only be processed by someone who knows what (s)he is doing, and never working alone.

Things to do every week

- Sweep and mop the floor. Note that this should be done with brooms and buckets of water, or long handled mops, not by pushing cloth on the floor directly with hands.
- Wipe down the chemical storage area. Check for broken and leaking bottles.
- Ensure that sinks (if present) are not clogged. If a sink is clogged, either unclog it immediately or prevent use of the sink by physically obstructing the basin and also writing a sign. Signs by themselves are often insufficient. Barriers with signs tend to get moved.

You can do this work or you can train students to do it. Supervise their work while they are learning to make sure they use safe techniques. Ensure that students never work alone – even for mopping at least two students must be present at all times. Students should not work in the chemical storage area without a teacher present.

Hands-On Activities

Physics Activities for Form I

10.1 Introduction to Physics

Concept of Physics

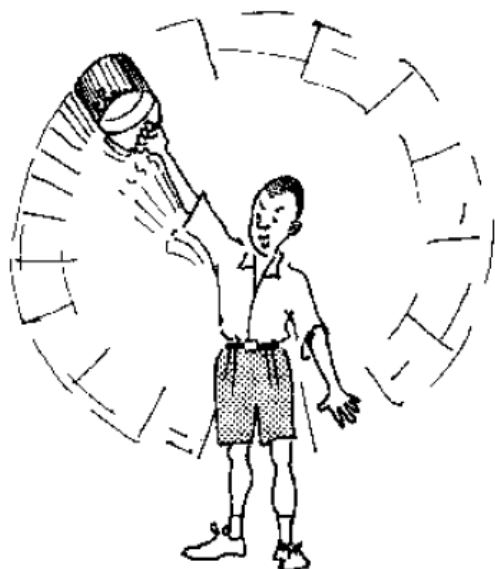

A bucket of water is sufficient to start investigating the effect of centripetal forces. Fill the bucket with various quantities of water and you will learn even more by doing. Increase the number of revolutions of the bucket.

Physics must not be a boring, tough subject, just good for exams and to be understood by a few “experts” only. Physics should not happen in books only. It is everywhere where things are. The teaching of science without experiments is just like a ngoma without dancers.

Pupils learn more and better by doing. Stimulate them to investigate their environment through easy to carry out experiments. Ask the pupils to make a list of physical phenomena which can be observed in their environment. Let the pupils enjoy physics. The activities in this book show how this can be achieved.

Applications of Physics

10.1.1 Measurement and Data



Imagine you would buy different kinds and different quantities of meat. The butcher will have to weigh and then calculate the price for each kind of meat and produce the total bill. Thus, measuring and the collection of data happen everyday in our life.

The tailor takes the measurements of his customer and of the material needed for a suit. The milkman measures the volume of the milk sold. The technician measures with a caliper the diameter of a screw and even at school the time of each period is measured. Especially in engineering precise measurements are indispensable.

10.1.2 Mechanics



Have you observed children balancing a plank like a seesaw? They know how a big and a small child can balance although they are of different weight.

Usually they do not know what a fulcrum, a load distance and a moment of force is. However, such basic mechanics dominate an essential part of our daily life. We encounter motion, friction, inertia, work and power almost every day. We also learn in a practical way about density, pressure of fluids or gases. Work, energy, power and other physical phenomena look very abstract in books but happen every day. Also the movement of earth, moon and the planets which determines the lengths of our days, months and years, has to do with basic mechanics such as motion, mass attraction and centripetal forces.

10.1.3 Matter

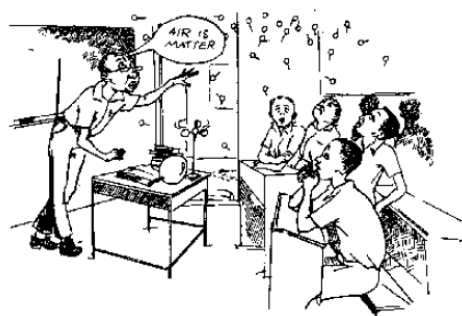

A chair can be touched. Water in a bucket also. But air? Can you imagine that while you are reading these lines your nose is punched more than 100 billion times by air molecules?

The environment around us, whether in solid, liquid or gaseous state is made up of billions of tiny particles which are either molecules or atoms. These particles which constitute air are so tiny, that we cannot see them even by a powerful microscope. However, the students can be given an idea of the particle structure of matter by indirect evidence.

10.1.4 Thermal Physics



Would you ever touch the handle of a hot pan? Would you put margarine just aside of the pot? Would you hold your hand right above the hot water? No; this is because we know a lot about thermal physics by daily experience. But we do not always relate this knowledge with what we learn at school about heat conduction, heat radiation or heat convection as is the case in the examples mentioned above.

Thermal physics has also to do with thermal energy and the measurement of temperatures, with calorimetry, change of states, expansion, etc. Ask the students to talk about everyday thermal phenomena and to write about these. Why should we teach this topic by talk and chalk only, if there are illustrative experiments which do not require a lot of equipment and which are not time consuming in their preparation and performance?

10.1.5 Wave Motion

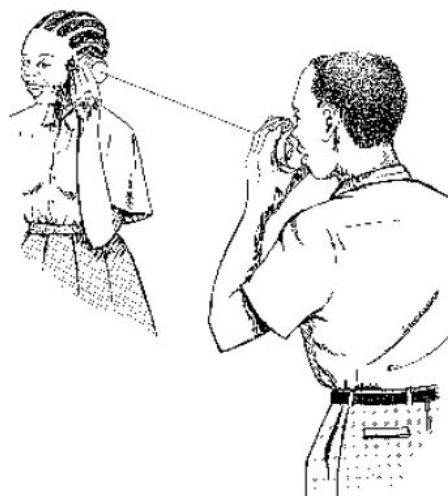

Communication through spoken words has to do with the transport of waves. Telephone and radio are well known. But do we think about waves when

we hear a music band, when a crow is croaking or when children are playing with a string telephone? All this is everyday knowledge about the transport of sound waves.

But teaching about waves does not mean only sound waves. Water waves we notice in a puddle as well as in a cup of tea. Electromagnetic waves are responsible for hearing our radios and watching our televisions. Produce waves in physics not only by talking. Meaningful and simple experiments are possible on many themes of this topic. No time? Hand experiments are always brief, illustrative and can be carried out with everyday things.

10.1.6 Light and Optics



When we hear about optics, the optician, eye glasses and lenses come into our mind. But that is not all what optics is about. Optics is also about the reflection of an image in a mirror or in a water puddle. The water surface is like a mirror. The image to be seen is inverted and it seems to be as far behind the water surface as the object is in front of it.

Perhaps there are no curved mirrors at your school to teach about concave and convex mirrors.

No problem. Take a polished spherical spoon and you will be able to perform an interesting lesson. Certainly not all themes can be taught by simple qualitative hand experiments only. But you may be astonished to see how many there are for eye catching demonstrations.

10.1.7 Electricity and Magnetism

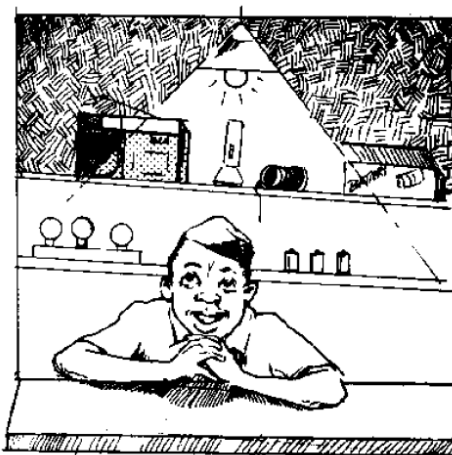

Effects of electricity can be observed nowadays nearly everywhere. A light bulb lights the room; a radio enchants our ears; a torch helps to find our way in the darkness; and last but not least we do owe a cool soft drink to a refrigerator. The understanding on how electric apparatus work is essential nowadays.

But electricity does not only mean a current flows in a circuit. It means also static electricity or lightning during a thunderstorm. The topic of electricity is closely related to magnetism. Without magnets electric motors would not work. Loudspeakers work with magnets and even a simple bicycle dynamo has one. In harbours you can see how “attractive” magnets can be to lift heavy loads. Do you think that the teaching of electricity by doing is difficult, needs a lot of equipment and is even dangerous? See that this is not the case by trying some of the activities provided in this manual.

10.2 Introduction to Laboratory Practice

Laboratory Rules and Safety

10.2.3 The Cleanliness Play

10.2.1 Display of Hazardous Chemicals



Procedure: Display some well labelled containers with hazard symbols for the students and let them talk about them.



Procedure: Ask the students to play group-wise short and funny scenes using appropriate words to make them familiar with cleanliness rules.

10.2.2 A Safety Game



Materials: Cards of hazard symbols

Procedure: Play a game with the symbol charts. A student is given a hazard symbol. He has to explain the hazard shown and to explain the necessary safety precautions in order to avoid that hazard.

10.2.4 The Tidiness Play



Procedure: Chemists are very tidy. Apparatus and reagents should be arranged on the table so that they can be reached easily but at a safe distance from the experiment.

The Scientific Method

The following activities can be used as a method of introducing students to the scientific method. Rather than just performing the activities, first identify the question or problem with the students, then have them form a hypothesis for each step of the experiment. Students should record observations and data accordingly and use them to draw a conclusion about the activity.

Prepare an activity sheet for each student or have them copy it into their notebooks before performing the activities. Set up stations for the various activities and have students rotate among them in small groups. Incorporate activities in Biology and Chemistry as well from the *Shika na Mikono* resource manual.

10.2.5 Complete the Circuit

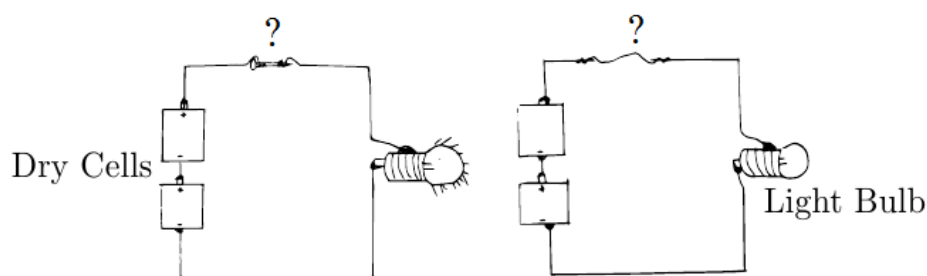

Materials: Dry cell, speaker wire, bulb/ammeter, cardboard, various objects, e.g. rubber band, nail, paper, aluminum foil, toothpick, pen, scissors, bottle cap, coin, balloon, chalk

Setup: Connect a dry cell and bulb in series using speaker wire and attach to a sheet of cardboard. Leave two wires free and pin to the cardboard to act as a switch.

Problem: Which objects will light a bulb?

Object	Hypothesis (Light or No Light)	Experimental Result
Copper wire		
Pen		
Aluminum foil		
Paper		
Nail		
Toothpick		
Bottle cap		
Balloon		
Chalk		
Scissors (blade)		
Scissors (handle)		

Hypothesis: Predict which materials will cause the bulb to light when placed across the switch. Record predictions in the table.

Procedure: Test each object by placing it by placing it across the free wires to close the circuit.

Observations: Record the result for each item in the table.

Questions:

1. Which materials caused the bulb to light?
2. These objects are made from what kind of materials?
3. What other objects in the room can you find to test? Will they light the bulb?

Theory: *Conductors* are materials which easily allow electrons to flow through them. *Insulators* are materials which do not easily allow the the flow of electrons. Examples of good conductors are most metals, water and the human body. Examples of good insulators are rubber, wood and plastic.

10.2.6 Density Tower

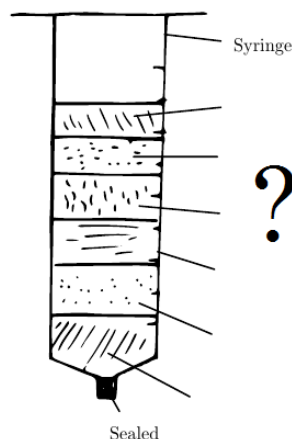

Materials: Syringes, bottles, water, cooking oil, kerosene, spirit, honey, glycerine, tape, scissors

Setup: Prepare a test tube rack by cutting a bottle and filling it with dirt. Remove the plungers from the syringes and seal them with tape, super glue, or by melting to opening closed.

Problem: Which liquids are more dense than others?

Liquid	Hypothesis (Position, 1 = bottom)	Experimental Result
Water		
Cooking oil		
Kerosene		
Spirit		
Honey		
Glycerine		

Hypothesis: Predict the order in which the liquids will settle from the bottom of the syringe. Assign 1 to the bottom liquid, 2 to the one above it, and so on.

Procedure: Pour a small amount of each liquid into a syringe, observing after each addition.

Observations: After adding all liquids, record the order in which they rest, starting with 1 at the bottom.

Questions:

1. Which liquid finished at the bottom?
2. Which liquid finished at the top?
3. Which liquid has the greatest density?
4. Which liquid has the lowest density?
5. What happens if you place a small object (e.g. paper clip, eraser, paper) in the tower?

Theory: *Density* is a property of different materials and liquids. It is a ratio of its mass to its volume. Dense liquids sink to the bottom, while less dense liquids rise to the top. A small object placed in the tower will settle in the liquid which is nearest its own density.

10.2.7 Sinkers and Floaters

Materials: Basin of water, various objects, e.g. nail, paper clip, paper, aluminum foil, soda cap, matchbox, pen cap, toothpick, balloons, flour

Problem: Which objects sink or float when placed in water?

Object	Hypothesis (Sink or Float)	Experimental Result
Nail		
Paper clip		
Pen cap		
Soda cap (dropped)		
Soda cap (placed carefully)		
Toothpick		
Paper		
Aluminum foil		
Matchbox		
Balloon (empty)		
Balloon (filled with flour)		
Balloon (filled with water)		
Balloon (filled with air)		

Hypothesis: Predict whether each object will sink or float when placed in the basin of water. Record in the table.

Procedure: Place each object in the water. First place them very carefully, then drop them in.

Observations: Record the results in the table.

Questions:

1. What factors affect whether an object sinks or floats?
2. How do large objects such as boats float?

Theory: *Flotation* depends on several things. A bottle cap placed carefully on the surface of the water will float, but when pushed under, will sink. A sheet of aluminum foil will float while a sheet of the same size which is folded several times will sink. A balloon filled with flour sinks, one filled with water just floats, and one filled with air floats above the surface.

If an object's *total density* is greater than that of water, it sinks, but if less than water, it floats. Air has a density less than water, so when air is trapped in objects such as bottle caps or balloons, they float because their total density is less than water. When air is removed (folded aluminum foil) or replaced by water (bottle cap), the total density of the object is just the density of the material. A matchbox pushed under water rises back to the surface because its density is less than that of water.

Boats are able to float despite being built from dense materials because of the large volume of water they displace and the large amount of air inside the boat. A boat with a larger surface area displaces a larger volume of water and thus can carry a larger load before sinking.

Follow up this activity with the *Raft Rally* science competition.

10.2.8 Mixing Colours

Materials: Various food colours, syringes, bottle, scissors, tape, paper

Setup: Prepare a test tube rack by cutting a bottle and filling it with dirt. Remove the plungers from the syringes and seal them with tape, super glue, or by melting to opening closed.

Problem: What happens when we mix different colours?

Colours to Mix	Hypothesis (What colour?)	Experimental Result
Red and green		
Yellow and blue		
Red and yellow		
All colours		

Hypothesis: Predict which colour will result when the two colours given are mixed together. Record it in the table.

Procedure: Use syringes to remove small amounts of each colour and place on a sheet of paper. Be sure to lay down plenty of paper so that the colours do not bleed through onto the table!

Observations: Record the resulting colour mixture in the table.

Questions:

1. How can you make orange from other colours?
2. What colour do you get by mixing all of the colours together?
3. What are some uses of coloured dyes?

Theory: Red, green and blue are *primary colours* of light. Other colours are made by different combinations of these primary colours. Coloured dyes are used for many applications, including clothes, paper and printing pictures.

10.3 Measurement and Density/Relative Density

Human progress is due, in large part, to an ability to measure and hence collect data with greater and greater precision. Young students should learn, generally, about how to obtain data by carrying out simple experiments. They should be introduced to the basic measurements of mass, distance and time. They should be trained in recording and in graphical analysis of data.

Collection of Data

10.3.2 Data on Distance

10.3.1 Data on Weighing

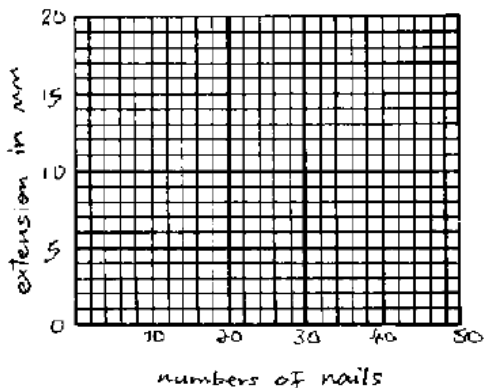
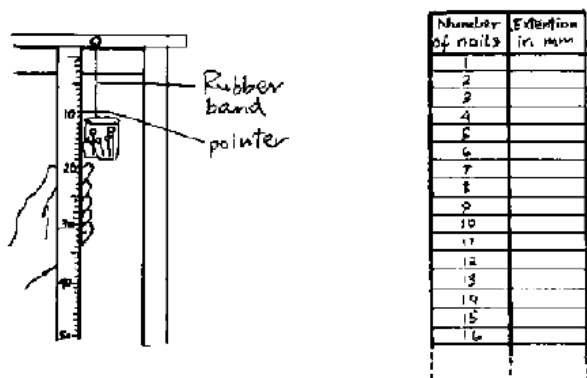

TURNS	DISTANCE

Fix a rubber band at one end to a table or retort stand. At the other end, attach a paper clip to act as a pointer and a small bag or scale pan. Fill the bag or scale pan with successive numbers of nails. Have students measure the extension of the rubber band each time they add more nails. Record the readings and use the data to draw a graph as shown in the figure.

Make a mark on the tyre of a bicycle at the point where it touches the ground. Turn the tyre by moving the bicycle forward and record the length of one turn. Repeat the experiment several times for various numbers of turns, each time recording the horizontal distance covered. Draw a graph to show the data.

10.3.3 Data on Time

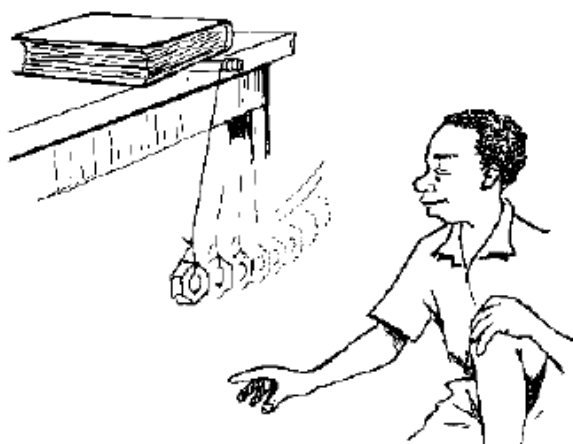

LENGTH OF PENDULUM	SWINGS		
	5 CM	10 CM	15 CM
50 CM			
75 CM			
100 CM			

Fix a string just off the edge of a table and hang a small weight (e.g. a nut or nail) at a distance of 50 cm. This is a simple pendulum. Pull the pendulum to one side so that its horizontal displacement is 5 cm. Count the number of oscillations (back and forth) made in one minute. Repeat by increasing the horizontal displacement to 10 cm and 15 cm. Then try varying the length of the string. How long must the pendulum be to oscillate 60 times in one minute?

10.3.4 Data on Velocity



Mark a distance of 100 metres along a nearby road or playground. Note the time taken for a car, a bicycle or a sprinter to cover the distance as follows. One pupil waves down his hand as either the car, bicycle or sprinter crosses the 0 metres mark. Another pupil with a watch, starts timing at the same time. A third pupil at the 100 metre mark waves down his hand as the moving object crosses the 100 metre mark and at this instant the timekeeper stops his watch.

Measuring Instruments

10.3.5 Construction of a Metre Rule

Materials: Wooden board, pen/pencil, a hand-saw, ruler or tape measure

Procedure: Use the handsaw to cut a piece of wood $100\text{ cm} \times 3.5\text{ cm} \times 0.5\text{ cm}$. Use a ruler or tape measure to mark a scale in cm on the wood.

Applications: Students can record data on their height, dimensions of the classroom, etc.

Notes: Instead of a wooden block, string can be used by making knots at different intervals.

10.3.6 Construction of a Beam Balance

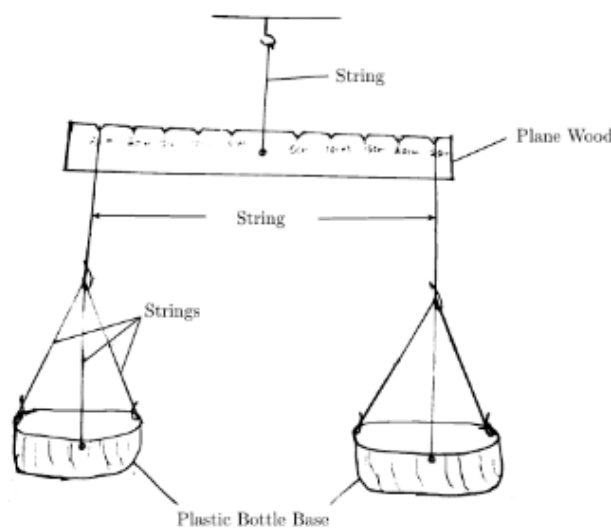

Materials: Ruler or wooden bar $30\text{ cm} \times 2\text{ cm}$, nails, razor/knife, string/wire, pen, 2 [Scale Pans](#)

Procedure: Find the balancing point of the ruler and mark it with a pen. Use a heated nail to make a hole through this point. Make notches at 5 cm intervals on either side of the center hole using a razor/knife to suspend scale pans. Suspend the balance with a string/wire.

Notes: Use locally available [Masses](#) to find the mass of everyday objects, e.g. notebooks, pens, rulers.

10.3.7 Scale Pans

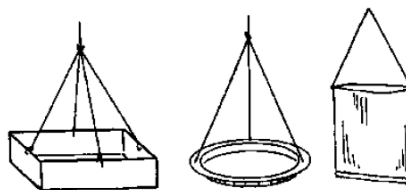

Materials: Match boxes, large plastic bottles, tin can lids, small plastic bags, knife, string

Procedure: Use a knife to poke 3 - 4 holes in the sides of one of the above materials. If using plastic bottles, cut them about 3 - 4 cm from the bottom. Cut equal lengths of string and tie them through the holes in the scale pan. Join the strings together at the upper end.

10.3.8 Construction of a Measuring Cylinder

Materials: Plastic bottles of different sizes, syringes (10 mL - 50 mL), marker pen, ruler, bucket of water

Procedure: Using the syringe, transfer a known volume of water from the bucket to the empty bottle. Use the marker pen to mark the level of water on the bottle. Repeat for a range of volumes, using a ruler to complete the scale.

10.3.9 Construction of a Eureka Can

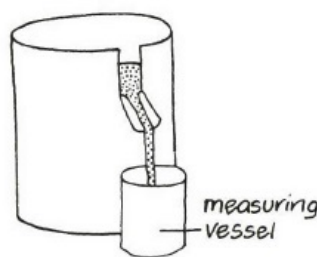

Materials: Plastic bottle, knife

Procedure: Cut a plastic bottle about 10 cm from the bottom. Cut 2 slits at the top of the bottle and bend the strip forward to form a spout.

Applications: Measuring the volume of irregular objects, Archimedes' Principle

Notes: Alternatively, use a bottle or tin can and poke a hole near the top using a heated nail. Attach a straw/hollow pen tube/tube of aluminum foil, using super glue to ensure an airtight seal.

10.3.10 Errors in Measurement

Materials: Metre rules, stopwatches

Procedure: (a) Draw a line on the board or floor. Have several students measure the length and secretly record their results. Collect the results and record them on the board, noting any differences.

(b) Distribute stopwatches to several students. Clap twice and have students measure the time between claps and secretly record their results. Collect the results and record them on the board, observing any differences.

Questions: What is the best result to use for each of the collected measurements?

Theory: Measurements vary from person to person. Every measurement comes with some level of error, and so it is important to take care when measuring to increase accuracy. The best result to use is the average of all the measurements.

Applications: Relative densities of liquids and solids help to identify certain substances, e.g. whether a ring is really made of gold.

Notes: Food coloring can be added to colorless liquids such as water, kerosene and glycerine to help distinguish among them.

10.3.12 U-Tube Apparatus

Materials: 3 clear plastic pen tubes, cardboard, heated nail or knife, tape, pen, super glue, water, kerosene.

Setup: Cut two of the tubes at one end to make a 45° angle, and cut the third tube (shorter than the other two) to make a 45° angle at both ends. Attach the two longer tubes to either side of the short one so that they make right angles and form a U-shape. Melt the angled ends together with a hot knife, soldering iron, etc. so that the apparatus is water-tight. Glue the assembly to a cardboard base so that it stands upright.

Place thin strips of tape along each side of the U-tube and mark with identical scales. Do this by adding known volumes of water and marking the levels on each scale. Label these marks from top to bottom as 0, 1, 2, etc.

Procedure: Place an amount of water into the U-tube such that the water rises about half way on either side of the tube. The actual volume of water is not important as long as you can see the levels clearly. Stand the tube upright and slowly drip about 1 mL of kerosene into one side of the U-tube. Measure the relative heights of water and the kerosene from the bottom level of the kerosene.

Observations: The kerosene will displace the water, so you should see the water level on the other side rise slightly.

Theory: If a fluid's density is less than that of water, it will float on top, displacing the water on the other side of the tube. From Archimedes' principle and the Law of Flotation, we know that

$$\frac{\text{height of water}}{\text{height of kerosene}} = \frac{\text{density of kerosene}}{\text{density of water}}$$

The scales drawn on the outside of the U-tube allow us to find the ratio of the heights without needing units, and the density of water is known to be 1.0 g/mL, so the density of the other fluid can be calculated.

Notes: If the other fluid has a higher density than water, the experiment can still be done, but the fluid with higher density must be added first, then displaced with water, performing the same calculation.

Density/Relative Density

10.3.11 Density Tower

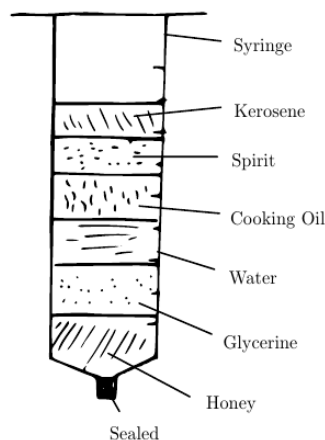

Materials: Syringes, water, honey, glycerine, cooking oil, spirit, kerosene, erasers, paper clips, nails, other small objects

Procedure: Add each liquid into the syringe, one by one, observing the relative depths of each liquid. Place small solid objects e.g. rubber erasers, paper clips, small nails, etc. into the syringe and observe their positions relative to the various liquids.

Questions: Which liquid is the most dense? Which is the least dense?

Observations: The denser liquids sink to the bottom while the less dense liquids rise to the top. The solid objects settle among liquids of comparable density.

10.4 Force

Concept of Force

10.4.1 Examples of Forces

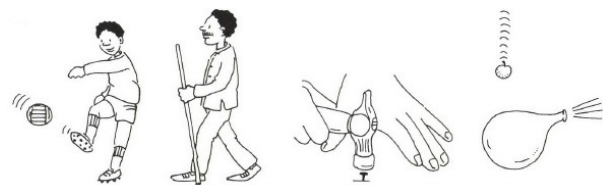

A **force** is any push or pull on an object. Examples of forces in our daily life include kicking a football, walking due to friction, hammering a nail and dropping an object. What other examples can you think of?

10.4.2 Making a Spring Balance

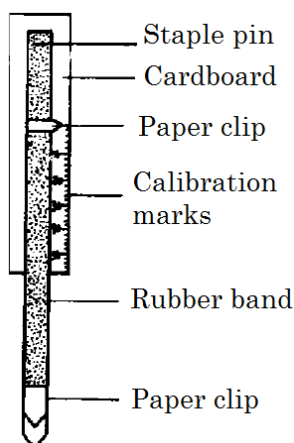

Materials: Cardboard, strong rubber band, staple pin, 2 paper clips, [Masses](#)

Setup: Take a strip of cardboard or wood and fix a strong rubber band to it using a staple pin. (The stronger the rubber band, the larger the force you can measure.) Attach one paper clip as a pointer as shown in the figure. Then fix another as a hook at the bottom end of the rubber band.

Procedure: Calibrate the balance in *Newtons* using either a standard set of [Masses](#) or another spring balance. A mass of 10 g has a weight of 0.1 N; a mass of 100 g has a weight of 1 N, etc. Draw marks accordingly on the scale of the balance.

Hazards: Never apply such a large force that the pointer does not return to the zero mark when the force ceases.

Applications: Use the spring balance to measure the weight of small objects or the force of pulling an object along a table.

Effects of Forces

10.4.3 Observing Effects of Forces

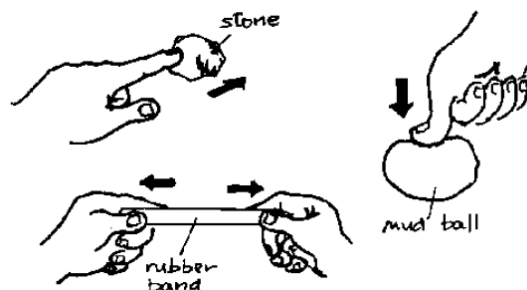

Materials: Rubber bands, springs, magnets, ruler, honey, water, paper

Procedure: Have students investigate different effects of forces using common materials.

Observations: Rubber bands and springs stretch when pulled and then restore their shape. Magnets attract and repel each other. A ruler can be twisted under torsion. Rubbing hands together produces heat from friction. Honey pours more slowly than water due to a higher viscosity. A sheet of paper falls to the ground slowly because of air resistance.

Applications: Brainstorm various applications of the effects of forces with the class.

10.4.4 Presence of Gravity

Materials: Pen, ruler, sheet of paper, book (same size as paper)

Procedure: Drop the pen and ruler side by side from shoulder height. Repeat with a pen and sheet of paper. Then place the paper on top of a book and drop side by side with a regular sheet of paper. Bunch the paper into a tight ball and drop it again with the book.

Questions: Which objects fell at the same rate? Which ones fell more slowly?

Observations: All objects, with the exception of paper and other light, wide objects, fall at exactly the same rate.

Theory: Gravity pulls on all objects on earth the same. The paper falls slowly because it is more affected by air resistance due to its small weight and large surface area. Placing a book under the paper reduces air resistance by blocking all of the air which would normally push against the paper. Thus they fall at the same rate. When the paper is bunched into a ball, the mass stays the same but the air resistance is greatly reduced so it falls at the same rate as the book.

10.4.5 Helicopters

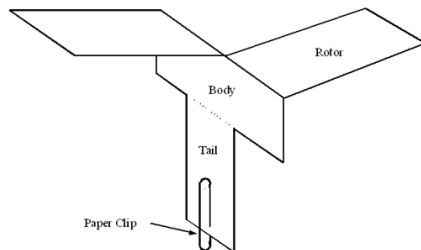
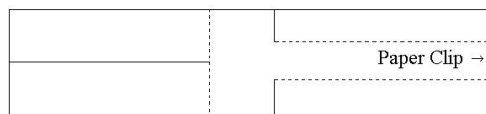

Materials: Paper, scissors, paper clip

Procedure: Copy the following design onto a piece of paper. Cut along the solid lines and fold along the dotted lines, attaching the paper clip to the bottom. Drop the helicopter with the paperclip down and watch it spin!

Questions: Does the helicopter spin more if you add more paper clips? If you change the size/number of wings?

Observations: Adding more paper clips causes the helicopter to spin faster. Increasing the surface area of the wings also increases the rate of spin.

Theory: The helicopter spins because the force of air resistance pushing up on the wings creates a moment about the vertical axis of rotation. Increasing the force of air resistance increases this moment and the helicopter spins faster.

10.4.6 Forces on Bridges

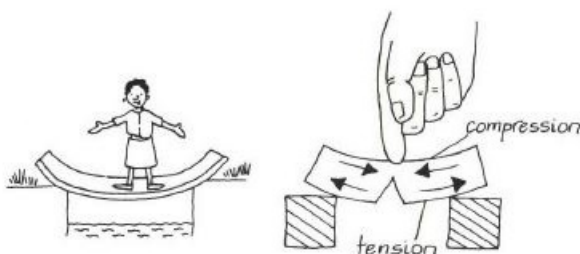

Theory: The bridge bends under the weight of the load. More than one force is at work. Compression forces are concentrated on the top surface. When a bridge bends, compression on top creates tension forces on the bottom surface.

10.4.7 Parachutes

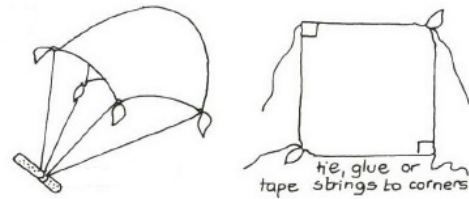

Materials: Paper/newspaper/plastic bags, string, paper clips

Setup: Tie pieces of string (about 30 cm) to each corner of the paper/bag. Join the four strings together and attach a paper clip or other small weight.

Procedure: Drop the parachute side by side with a normal paper clip.

Questions: Which one reaches the ground first? If the paper clip were a person, which one would arrive safely to the ground? Does a person using a parachute want to make it as large as possible or as small as possible?

Observations: The parachute falls more slowly because there is a larger space for air to enter and counteract the force of gravity pulling it to the ground.

Applications: Skydivers, military personnel, air-dropped aid packages. Follow up this activity with the *Egg Drop* or *Drop Zone* science competitions (see *Shika na Mikono* resource manual).

Notes: Poke a small hole in the top of the parachute and ask students what will happen.

10.4.8 Strengthening Bridges

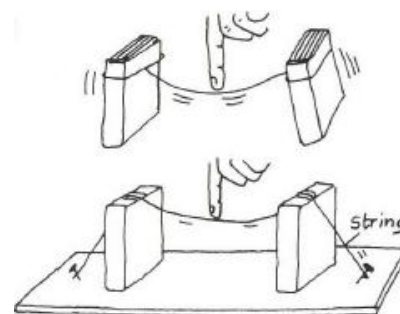

Materials: Books, string, nails, board

Procedure: Ask students to build the 2 bridges shown. Discuss why the suspension bridge is stronger.

Theory: In a suspension bridge the tension in the bridge is increased by securing the 'strings' and suspending them over towers or from trees.

Applications: Follow up the discussion by having students compete in the *Bridge Challenge* science competition (see *Shika na Mikono* resource manual).

10.5 Archimedes' Principle and the Law of Flotation

Concept of Upthrust

Archimedes' Principle states that any object partially or totally immersed in a fluid experiences an upthrust equal to the weight of the fluid displaced by the body.

$$\text{Upthrust} = \text{Weight of displaced fluid}$$

10.5.1 Verifying Archimedes' Principle

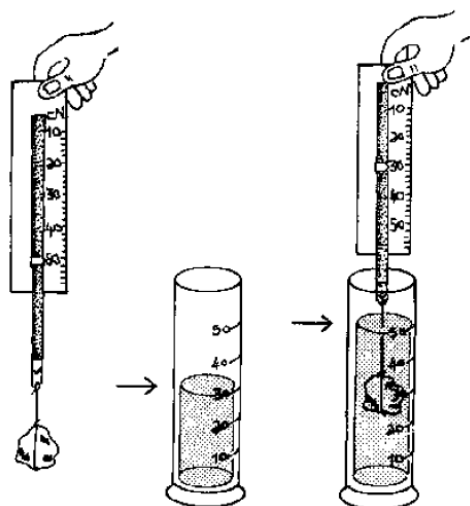

Materials: Spring Balance, stone, string, Measuring Cylinder, water, Eureka Can, syringe

Procedure: Tie a string around a stone and measure its weight in Newtons using a spring balance. Fill the measuring cylinder partially with water and record the reading. Immerse the stone fully into the water (without touching the bottom) and record the reading on the spring balance, as well as the new water level of the measuring cylinder.

Questions: What is the change in weight of the stone as read from the spring balance? What is the weight of the displaced water (1 mL = 0.01 N)?

Theory: The change in weight of the stone is known as its *Apparent Loss in Weight*, which is equal to the *Upthrust* exerted on the stone by the water. Archimedes' Principle tells us that this is equal to the weight of the water displaced by the stone.

Notes: A Eureka can and syringe may be used to measure the displaced fluid in place of a measuring cylinder.

Sinking and Floating

If the density of an object is less than that of the surrounding fluid, the object will float. If the density is greater than that of the fluid, it will sink.

The Law of Flotation states that a floating body displaces its own weight of the fluid in which it floats.

$$\text{Weight of body} = \text{Weight of displaced fluid}$$

10.5.2 Verifying the Law of Flotation

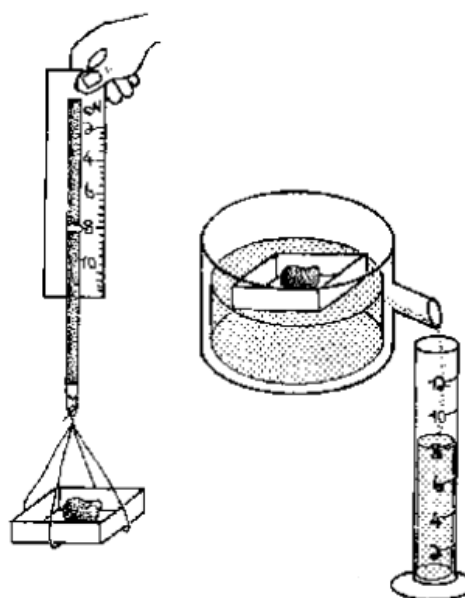

Materials: Spring Balance, matchbox, stone, string, Eureka Can, Measuring Cylinder/syringe

Procedure: Load a matchbox with a small stone so that it still floats in water. Record the weight of the matchbox and stone in Newtons using a spring balance. Fill the Eureka can with water and allow the matchbox to float on it. Collect the overflow in a measuring cylinder or syringe. Calculate the weight of the overflow (1 mL = 0.01 N).

Questions: How does the weight of the matchbox and stone compare to that of the displaced water?

Observations: The values should be equal, thus verifying the Law of Flotation.

Applications: Submarine, hot air balloon, ships. Design and selection of materials for these vessels are done using the Law of Flotation.

10.5.3 Sinkers and Floaters

Materials: Basin of water, various objects, e.g. nail, paper clip, paper, aluminum foil, soda cap, matchbox, pen cap, toothpick, balloons, flour

Setup: Fill one balloon with flour, one with water, and one with air. They should all be the same size.

Procedure: Have students predict the outcome for each object. Then place each object in the water, first by placing very carefully, then by dropping it in.

Object	Sink or Float?
Nail	
Paper clip	
Pen cap	
Soda cap	
Toothpick	
Paper	
Aluminum foil	
Matchbox	
Balloon (empty)	
Balloon (flour)	
Balloon (water)	
Balloon (air)	

Questions:

1. What factors affect whether an object sinks or floats?
2. How do large objects such as boats float?

Observations: A bottle cap placed carefully on the surface of the water will float, but when pushed under, will sink. A sheet of aluminum foil will float while a sheet of the same size which is folded several times will sink. A balloon filled with flour sinks, one filled with water just floats, and one filled with air floats above the surface.

Theory: If an object's *total density* is greater than that of water, it sinks, but if less than water, it floats. Air has a density less than water, so when air is trapped in objects such as bottle caps or balloons, they float because their total density is less than water. When air is removed (folded aluminum foil) or replaced by water (bottle cap), the total density of the object is just the density of the material. A matchbox pushed under water rises back to the surface because its density is less than that of water.

Applications: See the section on (p. 27) to conduct this activity as an experiment with students. Follow up this activity with the *Raft Rally* science competition (see *Shika na Mikono* resource manual).

10.5.4 Egg Float

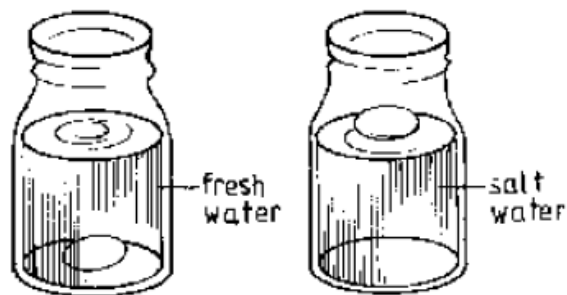

Materials: 2 fresh eggs, 2 containers (bottles cut in half), salt (less than half a cup)

Setup: Fill the two containers with water and place a fresh egg in each.

Procedure: Leave one as it is and add salt to the other. Add and mix salt until the egg floats in the saltwater container.

Questions: Why does the egg float in saltwater but sink in fresh water?

Theory: Saltwater has a greater density than fresh water. A fresh egg has a density between fresh water and saltwater. Since an egg is denser than freshwater, it sinks. Since an egg is less dense than saltwater, it floats.

Applications: This is the same reason why it is easier to stay afloat when swimming in the ocean (saltwater) as opposed to a lake (fresh water).

10.5.5 Floating Candle

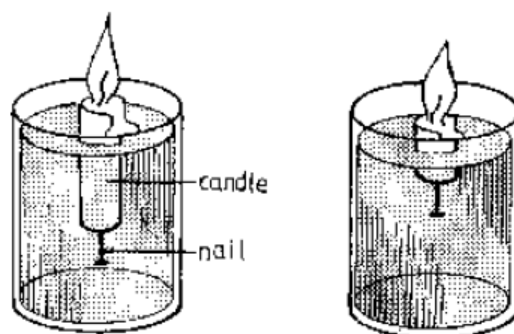

Materials: Candle, nail, container, water

Procedure: Put a nail into the bottom end of a candle so that the candle just floats with its top a bit above the surface of the water. Light the candle and watch as it burns up.

Questions: Why does the candle continue to float even though it loses weight as it burns up?

Theory: The candle continues to float because its density remains less than that of the surrounding water.

10.5.6 Cartesian Diver

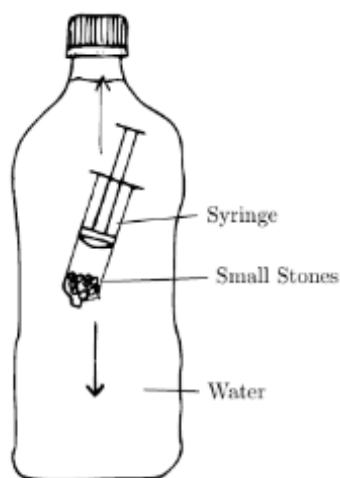

Materials: 1.5 L plastic bottle, balloon, paper clips (large), water

Setup: Fill the bottle with water. Fix a large paper clip to the lip of a balloon. Making sure to keep all air out of the balloon, insert it into the bottle. It should just float at the top while remaining completely submerged. Adjust depending on type of balloon and paper clips.

Procedure: Screw the cap on the bottle and squeeze the middle of the bottle, then release.

Observations: The balloon should begin to sink when you squeeze, but float again when you release.

Theory: While water is nearly incompressible, the balloon (and any small amount of air inside) is compressible. This means when you squeeze the bottle, the water remains unchanged, but the balloon is compressed, decreasing its volume and so increasing its density. Before squeezing, it was less dense than the water and so it floated. After squeezing, it becomes denser than the water and sinks.

10.5.7 The Hydrometer

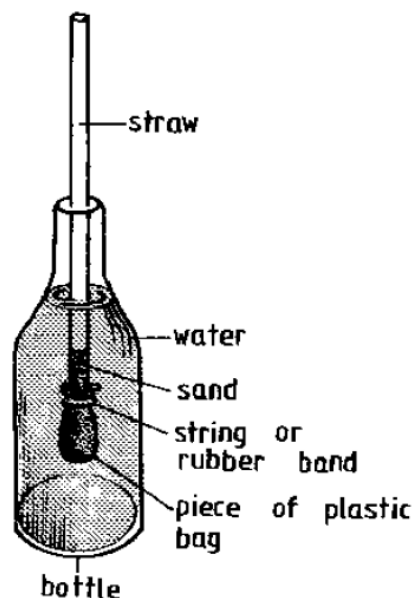

Materials: Bottle, straw, plastic bag, dry sand, rubber band/string, pen, ruler, water, kerosene, other liquids

Setup: Close one end of the straw with the plastic bag and secure it with the rubber band so that water cannot enter. Pour sand into the straw until it floats upright in the bottle of water without touching the bottom or leaning.

Procedure: Use a pen to mark the water level on the outside of the straw. Label it 1.0 (the density of water in g/cm^3). Place the straw upright in a container of kerosene. Mark the kerosene level on the straw as 0.8 (known density of kerosene). Remove and clean the straw, without getting any liquid inside. Use a ruler to complete the scale above 1.0 and below 0.8, beginning with 0.9 at the midpoint. Use the hydrometer to measure the densities of other liquids.

Questions: Why do smaller numbers appear at the top of the hydrometer scale?

Theory: Liquids with a lower density allow the hydrometer to sink deeper, and thus the liquid reaches a higher point on the scale.

10.6 Structure and Properties of Matter

States of Matter

10.6.1 Student Particles



Procedure: Use students to demonstrate the concept of states of matter.

Theory: When students or objects are close together, they represent particles in the *solid* state. As they move apart and past each other they represent particles in the *liquid* state. Fast and randomly moving pupils or objects represent particles in the *gaseous* state.

10.6.2 A Model of Motion

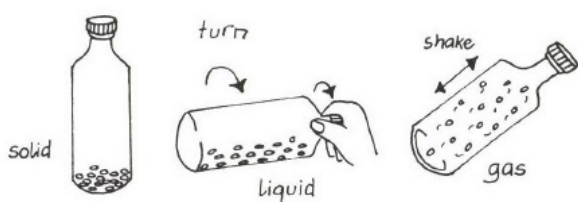

Procedure: Put some dry beans, rice or stones in a clear bottle. Hold the bottle still, then turn it, then shake it vigorously.

Questions: Which activity corresponds to which state of matter?

Theory: The movement of particles in solids is small and hence they are in fixed order. In liquids the particles move past each other and have lost the stiff order. In gases they move very fast and randomly, losing all order.

10.6.3 Changes of State

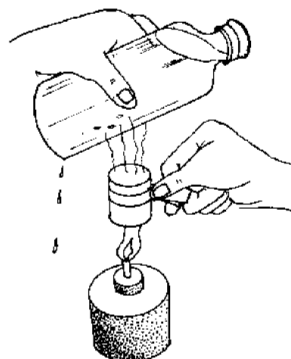

Materials: Tin can, glass bottle, water, [Heat Source](#)

Procedure: Pour a small amount of water into a tin can and heat it until it boils. Fill a bottle with cool water and hold it above the tin can.

Observations: Water drops form on the outside of the cool bottle when it is touched by the steam of the boiling water.

Theory: Water particles escape from the boiling water as vapour and condense on the lower surface of the bottle to form water droplets. Hence water is made up of small particles.

10.6.4 Model of Brownian Movement



Imagine there would be standing a tall adult person around whom small children are in a continuous random movement. The tall person would be punched permanently by the children and hence would be jerkily moved.

Particulate Nature of Matter

10.6.5 Salt is Made of Particles

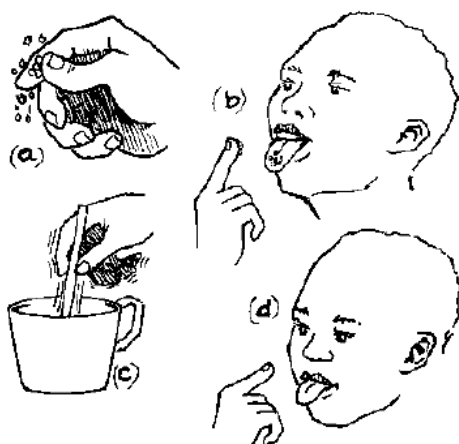

Materials: Salt/sugar, cup, water

Procedure: Roll some salt or sugar crystals between your fingers. Taste the crystals. Take a sip of the water. Now put the salt or sugar in the water and shake it. Taste again.

Theory: Sugar and salt are made up of tiny particles that can be identified by tasting even though they can not be seen in a solution.

10.6.6 Weighing Particles

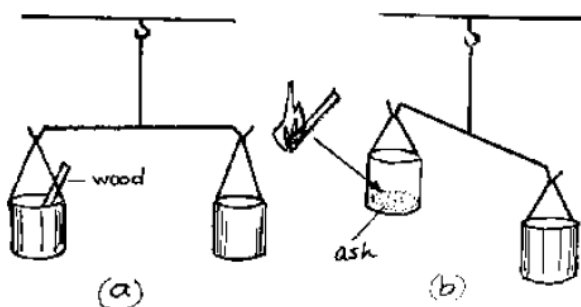

Materials: Balance, small pieces of wood, Heat Source

Procedure: Weigh pieces of wood and record the weight. Then burn the wood and weigh the ash.

Questions: Is there a difference between the two weights?

Theory: The weight of the ash is less than that of wood. The loss in weight is due to particles which escaped as soot and gas.

Applications: This is why garbage reduces in size when burned. Burning wood and garbage releases carbon dioxide and other harmful gases into our environment. This is one form of pollution.

Elasticity

10.6.7 Hooke's Law

NECTA PRACTICAL

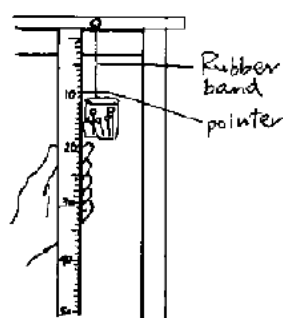

Number of nails	Extension in mm
1	
2	
3	
4	
5	
6	
7	
8	
9	
10	
11	
12	
13	
14	
15	
16	

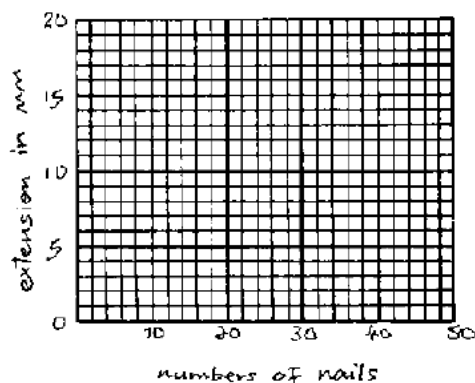

Materials: Rubber band/elastic strip, ruler, wire, Scale Pans, nails/small Masses, tape

Setup: Fix a ruler and rubber band side-by-side to a table or retort stand. At the other end of the rubber band, attach a small length of wire to act as a pointer and a small bag or scale pan (e.g. cardboard tube).

Procedure: Fill the scale pan with regular increments of nails or known weights. Have students measure the extension of the rubber band after each addition. Record and use the data to draw a graph of force (weight) against extension.

Questions: What is the relationship between number of weights added and extension of the rubber band? What does the slope of the graph represent?

Theory: Hooke's Law states that the force applied to an elastic object is directly proportional to its extension ($F = kx$). The slope represents the elastic constant of the material.

Adhesion and Cohesion

Forces between particles of the same material are called *cohesive forces* while those between particles of different materials are called *adhesive forces*.

10.6.8 Adhesion of Glass and Water

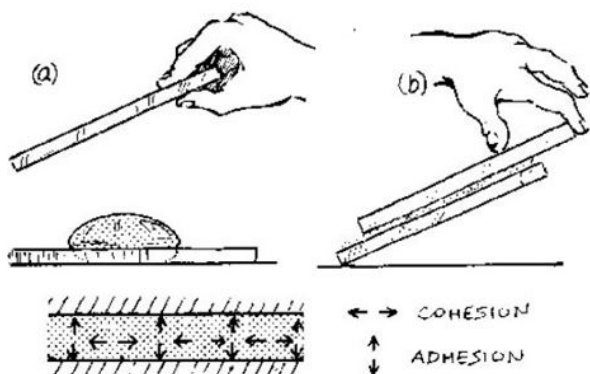

Materials: 2 glass sheets, water, straw

Procedure: Drip water on a clean glass sheet (a). Place a second glass sheet on the wet first sheet and try to lift it (b).

Theory: (a) Water spreads to form a patch on the first glass surface because *adhesive forces* attract water molecules to the glass surface. (b) A strong force is required to separate the two glass sheets because the adhesive forces between glass and water are large.

10.6.9 Pinching Water

Materials: 500 mL water bottle, needle/pin

Setup: Make 5 small holes at the bottom of the bottle with a syringe needle or nail. Make them close together (about 5 mm apart).

Procedure: Fill the bottle with water and allow it to flow through the holes at the bottom. Use your thumb and forefinger to pinch the streams together to form a single stream. Pass your hand over the holes and all five will appear again.

Theory: Water has a tendency to cling to itself due to its surface tension and cohesion. As you bring the streams together, you allow the water to stick to itself forming a single stream. Passing your hand in front again stops the flow of water and allows it to start again in five streams.

10.6.10 Exploring Adhesion and Cohesion

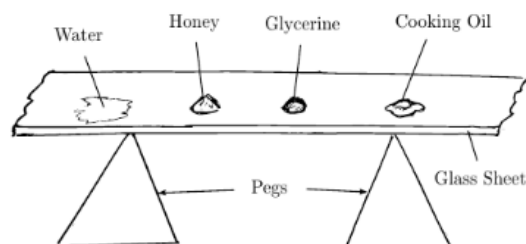

Materials: Sheet of glass, water, honey, glycerin, cooking oil, syringe, and 2 wooden blocks

Procedure: Place a sheet of glass over two wooden blocks on a table. Using a syringe, place a drop of different liquids on the glass.

Observations: Water spreads and wets the glass, while honey, glycerin and cooking oil remain in a spherical shape.

Theory: The adhesive forces between the water molecules and glass molecules are greater, while the cohesive forces between the molecules of honey, glycerin and cooking oil are larger.

10.6.11 Water Drops

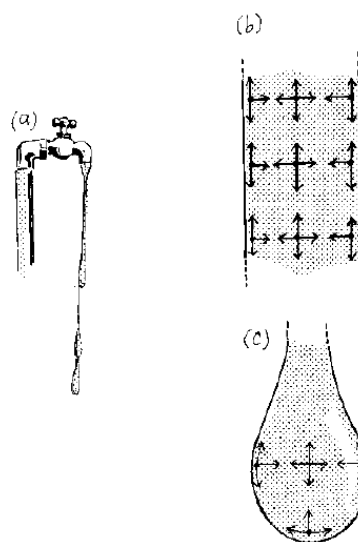

Materials: Syringe or water dropper

Procedure: Slowly drip water from the syringe or water dropper. Observe how the drop forms.

Observations: The water stream grows thinner and thinner as it moves further down and finally breaks to form drops.

Theory: Strong cohesive forces hold the water molecules together, until they are overcome by gravity and the water breaks off as drops.

Surface Tension

10.6.12 Water Dome



Materials: Coin, water, syringe or eyedropper

Procedure: Place the coin flat on a table. Use the syringe or eyedropper to carefully drop individual water drops onto the coin.

Questions: How many drops do you think the coin can hold?

Observations: The coin holds a surprising number of drops and forms a dome shape before the water spills over.

Theory: The surface tension of the water holds it together against the force of gravity, which is trying to pull the water off the coin.

10.6.14 Overflowing Glass

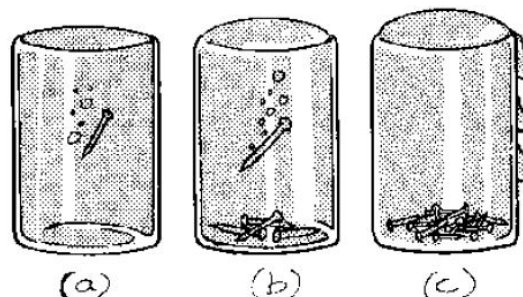

Materials: Glass cup, water, nails

Procedure: Carefully fill a transparent glass vessel with water to the rim. Add nails, one at a time, to the water and count the number of nails sunk just as water begins to spill over.

Observations: The water surface bulges out but does not break immediately because of strong *cohesion forces* between the water particles.

10.6.13 Pin Float

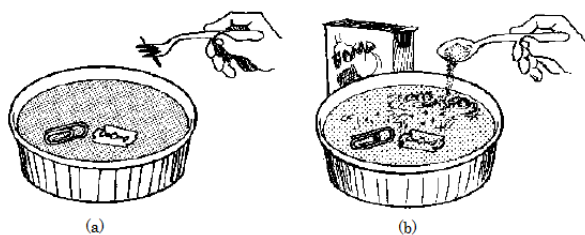

Materials: Cup or small dish, straight pin/razor/paper clip, water, detergent

Procedure: Fill the cup with clean water and carefully float a pin, razor or small paper clip. Now add a small amount of detergent to the water and observe what happens.

Observations: The objects float on the surface of the water initially, but after adding detergent, they sink to the bottom.

Theory: The surface tension of the water acts as an elastic membrane and is strong enough to support the small objects. Soap lowers the surface tension of water and therefore the objects sink.

10.6.15 Blowing Bubbles

Materials: Thin piece of wire (approximately 30cm), water, detergent, glycerin (optional)

Setup: Bend the wire to form a loop of 2 to 3 cm in diameter, circling this loop many times. Leave a straight piece several cm long as a handle. Make a concentrated solution of detergent in water with a small amount of glycerin.

Procedure: Dip the circular part of the wire into the detergent. You should see a thin soapy film across the circle upon removal. Gently blow through the circle until a bubble separates from the wire.

Observations: While blowing, the solution is being pulled back towards the surface. Once it breaks free as a bubble, it forms a spherical shape.

Theory: The surface tension of water causes the bubble to form the shape with the minimum surface area, which is a sphere.

Capillarity

10.6.16 Capillary Rise

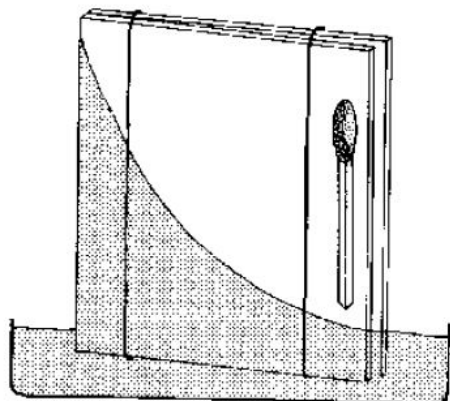

Materials: 2 glass sheets, match, rubber bands, water, food colour (optional)

Procedure: With the help of a rubber band and a matchstick, arrange two clean glass sheets as shown in the diagram. Place the arrangement in a plate containing some water.

Observations: Water rises to different heights along and between the glass sheets.

Theory: This is capillary action. Capillary rise results from adhesion, allowing the liquid to climb along the surface of the glass, as well as cohesion, which pulls the remainder of the liquid up. Water rises more where the glass sheets are closer together.

10.6.17 Moving Matches

Materials: Matches, water, straw, plastic lid

Procedure: Break several matches near the middle, but not so that they come apart. They should make acute angles. Place them on the plastic lid and place a few drops of water on the broken joints of the matches using the straw.

Observations: The matches close and return to their original straight shape.

Theory: Water gets absorbed in the wooden matchstick and causes it to expand.

Applications: This is why it is difficult to open a wooden door after it rains. The water rises up the wood causing it to expand into its frame.

10.6.18 Measuring Capillary Rise

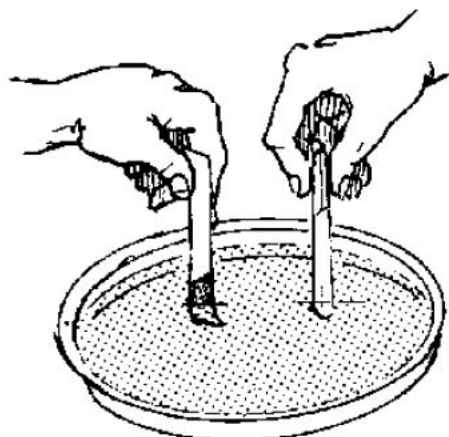

Materials: Paper, chalk, small dish/lid, water, food colour

Setup: Cut off the bottom of a plastic bottle to make a water dish.

Procedure: Place a strip of paper and a piece of chalk in a dish containing water. Leave the objects for some time and measure the rise in colour of each using a ruler.

Observations: The water rises faster in the chalk than in the paper.

Theory: Chalk has smaller capillaries than paper, which allows water to rise faster.

10.6.19 Automatic Irrigation



Applications: Capillary action can be used to provide automatic irrigation for plants. Students can perform irrigation by dipping a porous material such as paper or cotton cloth in water.

Diffusion

10.6.20 Diffusion in Liquids

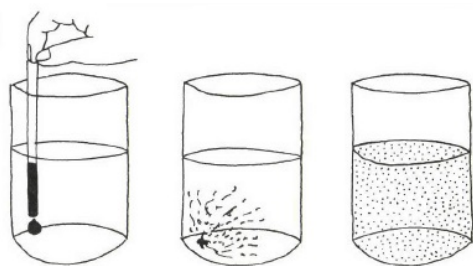

Materials: Plastic water bottle, food colour (liquid or powder)

Procedure: Put a drop or small amount of powdered food colour into the water without shaking and observe what happens.

Observations: The colour gradually spreads throughout the water.

Theory: This spreading is due to the motion of the particles of food colour. This process is called *diffusion*.

Applications: Organisms utilize diffusion to balance nutrient concentrations in cells and to transfer oxygen into the bloodstream during respiration.

10.6.21 Smelling Particles

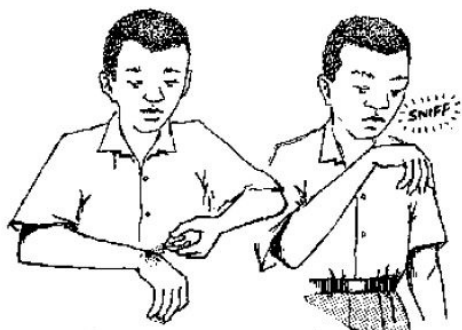

Materials: Orange or other citrus fruit, box

Procedure: Peel an orange and have students raise their hands when they begin to smell it. Now place a box in front of the orange and repeat the test.

Observations: Students in the front center of the room should be the first to raise their hands, followed by those near the sides and in the back. When the orange is peeled behind the box it takes longer for the smell to reach the students.

Theory: Tiny particles from the orange peel spread by diffusion to students' noses. The box hinders the motion of the particles and so they reach the students more slowly.

Applications: Air fresheners and other sprays

10.6.22 Diffusion in Daily Life

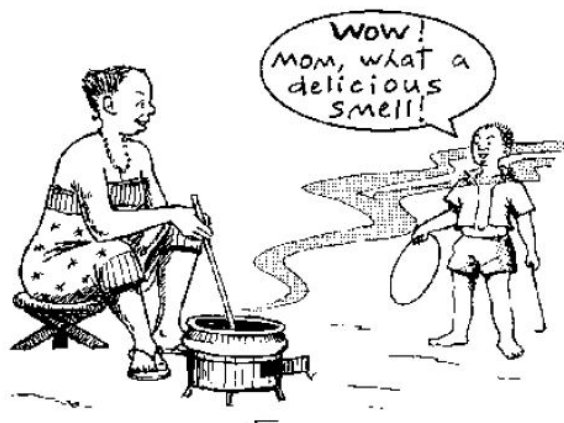

Procedure: Pass near a place where people are roasting meat or cooking.

Theory: The smell is sensed even at a distance, because the particles which produce the smell spread by *diffusion*.

10.6.23 Diffusion and Pollution



Procedure: Pass near a polluted area (e.g. latrine, burning heaps of litter, a filling station).

Theory: Many hazardous substances spread to the environment by diffusion. (Hazardous substances in any state of matter in our environment mean pollution.)

Osmosis

10.6.24 Vanilla Balloon

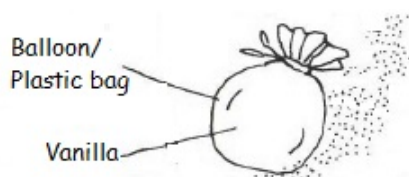

Materials: Balloon/plastic bag, vanilla, straw/syringe

Procedure: Place a few drops of vanilla in a deflated balloon. Now blow up the balloon and tie it shut.

Observations: You can smell the vanilla through the surface of the balloon.

Theory: The balloon acts as a *semi-permeable membrane* which allows some of the vanilla particles to pass through and reach your nose. Other particles remain inside the balloon.

10.6.25 Potato Osmosis

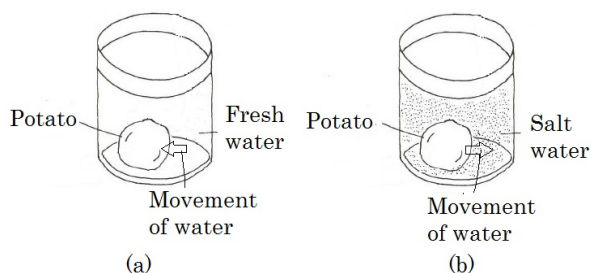

Materials: Potato, 2 water bottles, salt, water

Setup: Cut two equal size pieces of potato. Fill one bottle with fresh water and the other with a salt water solution.

Procedure: Put one piece of potato in each bottle. Observe over the next few hours.

Observations: The potato in fresh water swells while the potato in salt water shrivels up.

Theory: Through osmosis, water moves from a region of low concentration to one of high concentration through a semi-permeable membrane (the potato). In fresh water, the potato has the higher salt concentration, so water enters in order to make a balance. In salt water, the concentration of the surrounding water is higher than that of the potato, so water inside the potato moves outside to dilute the salt solution.

Notes: Try this experiment again with a boiled potato. Do you observe any differences?

10.6.26 Semi-Permeable Membranes

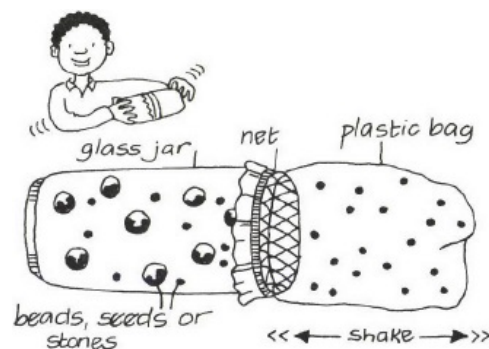

Materials: Glass jar, clear plastic bag, small beads or stones, beans, netting, string/rubber band

Setup: Place the mixture of beads and beans in the jar. Place the net and plastic bag over the top and tie them on securely.

Procedure: Shake the apparatus for a few seconds.

Observations: Only the small beads pass through the netting. The beans remain in the jar.

Theory: The beads represent small molecules and the net is a semi-permeable membrane. The beans are too large to pass through and hence remain in the jar.

Applications: Water filters, organism cell membranes

10.6.27 Osmosis with Eggs

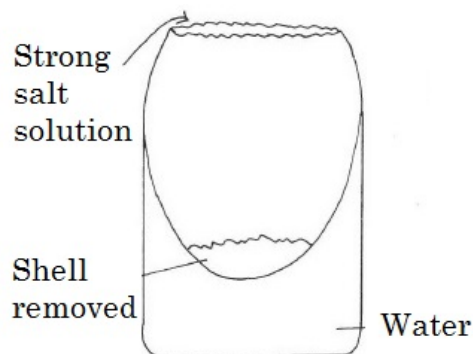

Materials: Empty eggshell, strong salt solution, jar of water

Procedure: Remove the hard outer shell at one end of the eggshell to expose the inner membrane. Half fill the egg with salt solution and place it in the jar so that the water level is above the exposed membrane and leave for a couple of hours.

Observations: The level of the solution inside the egg rises, indicating water has crossed the membrane, i.e. osmosis has occurred.

Theory: Water travels from an area of low concentration to an area of high concentration of salts.

10.7 Pressure

Concept of Pressure

10.7.1 What is Pressure?

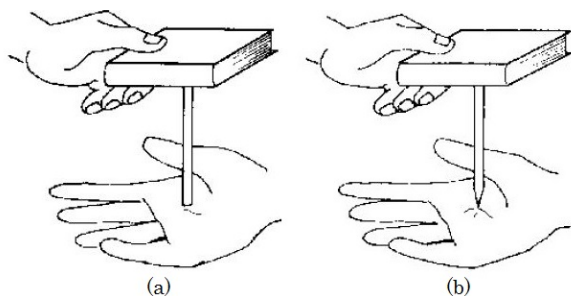

Materials: Pencil, book

Procedure: Ask a student to support a book as shown in figure (a). Then turn the pencil upside down as shown in figure (b).

Observations: In case (b) the student will feel pain on the hand supporting the pencil.

Theory: In case (b) the force with which the pencil acts on the hand is the same (equal to the weight of book plus pencil) as in case (a) but the pressure on the hand has increased very much since the area on which the pencil touches the hand has decreased so much.

Applications: Large area feet of elephants; wide tyres of tractors; wide chains of caterpillar machines.

10.7.2 Balloon Pop

Materials: 2 pieces of wood, nails, balloons, water

Setup: Put a single nail through one piece of wood and for the other, put many nails closely spaced. Blow up 2 balloons or fill them with water.

Procedure: Slowly press one balloon against the single nail until it pops. Then repeat for the cluster of nails.

Observations: The balloon pops easily on the single nail, though it may not pop at all on the cluster of nails.

Theory: Using many nails increases the area over which the force of the nails act, thus decreasing the pressure and requiring a greater force to make the balloon pop.

Notes: You can also hang the balloon from a spring balance as you lower it onto the nails. The difference in weight gives the force needed to pop the balloon.

10.7.3 Carrying a Load on the Head

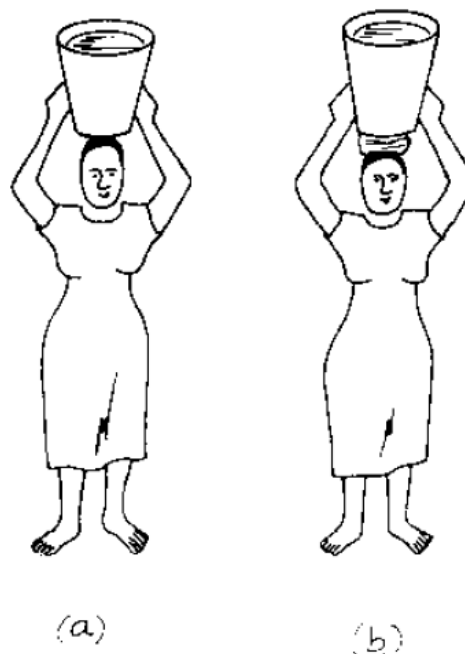

Procedure: Carry a bucket on your head without (a) and with (b) a cloth or khangha.

Questions: Which is more difficult?

Theory: Using the cloth causes the force of the bucket to be more evenly distributed across a larger area. Hence the force felt at any single point is reduced.

10.7.4 Potato Poke

Materials: Straw, potato

Procedure: Try to stab a straw into the potato. Now place your thumb firmly over one end of the straw and try again.

Observations: The straw bends easily and does not harm the potato the first time. When you cover one end of the straw, it enters the potato easily and may even break through the other side.

Theory: Holding your thumb over the straw traps air inside which increases the pressure in the straw. When it strikes the potato, the increased pressure prevents it from bending and so it is able to poke through the potato.

Pressure in Solids

10.7.5 Effect of Surface Area on Pressure

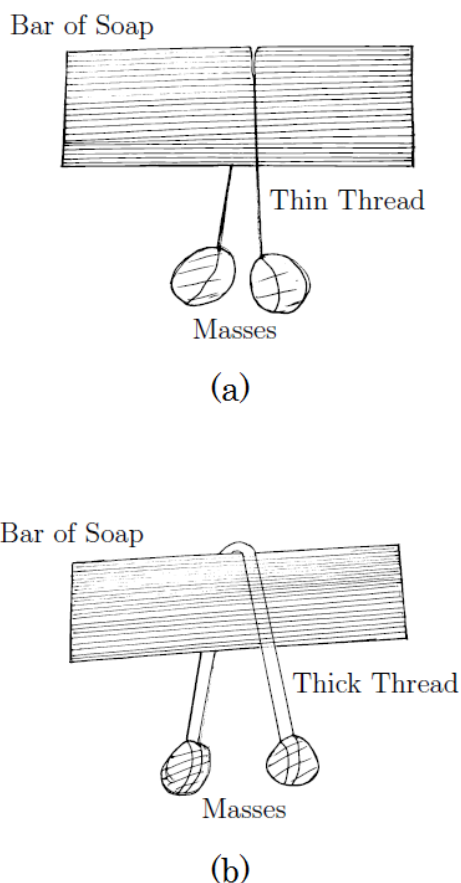

Materials: Bar of soap, thin thread, thick string, 4 heavy stones of approximately equal weight

Procedure: Tie a heavy stone to either end of both the thin thread and thick string. Hang each thread across the bar of soap so that the weights hang freely.

Observations: The thin thread easily cuts through the soap, but the thick string does not.

Theory: The smaller area of the thin thread, acting with the same force, results in an increased pressure which is enough to cut through the soap.

Pressure in Liquids

10.7.6 Pressure Increases with Depth

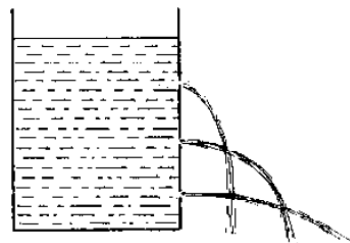

Materials: 1.5 L bottle, syringe needle or pin/nail, water

Setup: Poke three holes into a bottle. Put one hole near the bottom, one near the middle, and the last hole between them.

Procedure: Fill the bottle with water and place on a table. Observe the trajectories of water coming from the three holes.

Questions: Which stream goes the farthest distance horizontally? Which hole has the highest pressure?

Observations: The water flowing from the lower holes travels farther.

Theory: The added weight of the water above the lower holes increases the pressure there, resulting in an increased horizontal velocity. It is shown that pressure increases with depth ($P = \rho gh$).

Applications: The wall of a dam is made much thicker at the bottom than at the top. This is to reinforce against the increased water pressure at greater depths.

10.7.7 Pressure Acts in All Directions

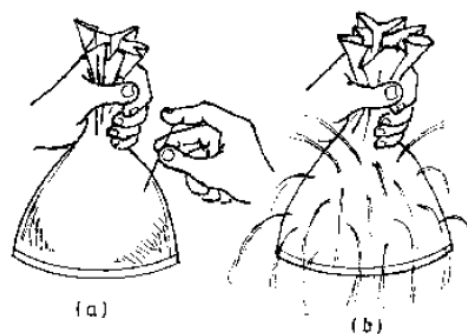

Materials: Water bottle/balloon/plastic bag, pin/needle, water

Procedure: Fill a bottle, balloon or plastic bag with water. Poke several small holes around the surface.

Observations: Water is expelled equally through all of the holes.

Theory: Pressure in a liquid acts equally in all directions.

10.7.8 Straw Fountain

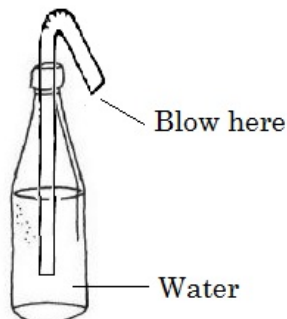

Materials: 500 mL water bottle with cap, water, straw, glue, hot nail/pin

Setup: Poke a hole the size of the straw in the bottle cap using a heated nail or pin. Stick the straw through the hole and screw on the cap so that the straw reaches near the bottom. Glue around the straw so that it is air tight.

Procedure: Fill the bottle about half way with water and close the cap with the straw inside. Have a student blow as hard as they can through the straw into the water and then stop.

Observations: When the student stops blowing, they get sprayed in the face by water.

Theory: Blowing into the bottle greatly increases the pressure inside. When you stop blowing, the pressure equalizes by forcing water back out through the straw.

10.7.9 Hydraulic Press

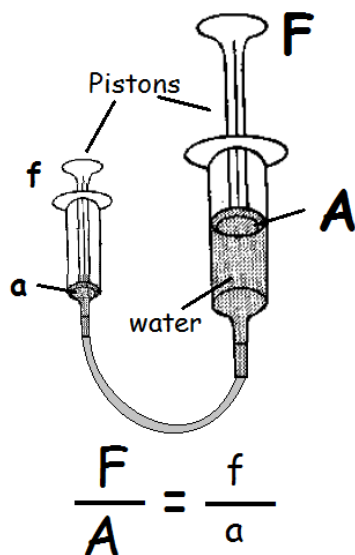

Materials: 2 syringes of different size (5 mL and 20 mL), Delivery Tube, water

Setup: Fill the larger syringe with water and attach one end of the rubber tubing to its end. Attach the other end of the tubing to the smaller syringe (with its plunger inserted all the way).

Procedure: Pushing the plunger of the larger syringe will cause the plunger of the smaller syringe to go out, and vice-versa.

Observations: It is easier to push the plunger of the small syringe than that of the larger syringe.

Theory: Pascal's principle states that pressure is distributed equally throughout a liquid. Thus, the pressure at one plunger must be equal to the pressure at the other plunger. Setting the two ratios equal, we can see that a small force over a small area can overcome a large force over a large area.

Applications: Industrial machinery, hydraulic breaks

10.7.10 The Manometer

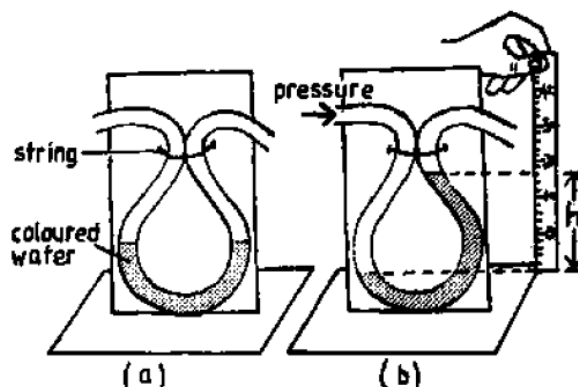

Materials: Delivery Tube, ruler, cardboard, string, water, food colour, water bottle

Setup: Create the manometer as shown by attaching thin tubing in a U-shape to a cardboard stand and filling with a small amount of coloured water. Make sure there is sufficient length of tubing left over on either side.

Procedure: Insert each arm of the manometer to a different depth in a bottle of water.

Observations: When both arms are at equal pressure, the water levels are equal. When one side experiences a higher pressure, there is a noticeable difference in the height h of coloured water on the opposite side.

Theory: A manometer is used to measure fluid pressure. When the pressure is higher on one side, it is shown by a difference in height on the manometer which can be measured. The greater the pressure difference, the higher the value of h .

Atmospheric Pressure

10.7.11 Overturned Glass

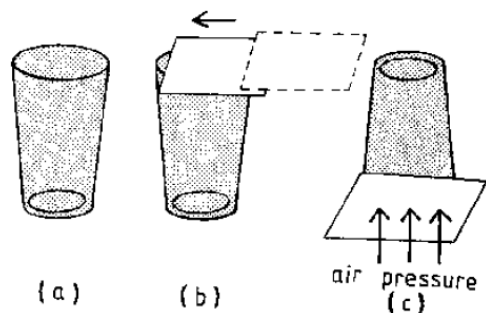

Materials: Cup/glass, card, water

Procedure: Fill a cup to the rim with water. Push a smooth card from the side to cover the glass so that no air bubbles are included. Turn the glass upside down.

Questions: Why can there be no air bubbles inside the glass?

Observations: The card remains attached to the glass and the water does not fall out.

Theory: The card is held in place by atmospheric pressure pushing upwards, which is larger than the weight of the water pushing downwards, so the card does not fall.

10.7.12 Holey Bottle

Materials: Water bottle, pin, water

Procedure: Poke 4 or 5 small holes in the bottom of the bottle. Fill it half way with water, allowing it to spill out the holes in the bottom. Then cap the bottle and observe what happens.

Observations: When the bottle is capped, the water stops flowing through the holes.

Theory: When the bottle is open, gravity is strong enough to pull the water through the bottom holes. When closed, however, the low pressure inside the bottle and the high atmospheric pressure outside creates an upward force that is able to overcome gravity and prevent water from flowing.

10.7.13 Bottle Crush

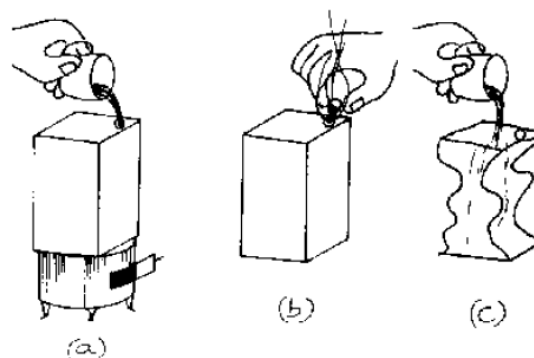

Materials: Plastic water bottle, boiling water, cold water

Procedure: Pour some boiling water into the bottle and cap it immediately. Shake it to make sure all the air inside is heated. Then pour cold water on the bottle.

Observations: Upon pouring the cold water, the bottle crushes.

Theory: When the hot air inside the water bottle is cooled off, its volume decreases, leaving a partial vacuum inside the bottle. The greater atmospheric pressure outside crushes the bottle inwards.

10.7.14 Automatic Flushing Tank

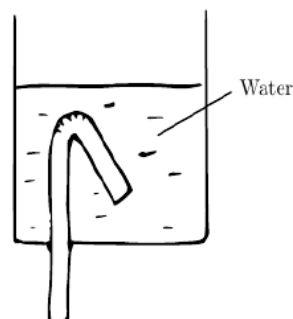

Materials: Empty water bottle, straw, water, bucket, super glue

Setup: Cut the top off of a water bottle and make a hole at the bottom for a straw to fit through. Bend the straw inside the bottle as shown and seal with super glue.

Procedure: Fill the bottle up to and above the bend in the straw and observe what happens.

Observations: The water will flow into the bucket through the bent straw.

Theory: The combined pressure of the water and the atmosphere pushing down on the water is greater than the air pushing up on the straw. The tank does not require a handle to trigger the flush. Once the water flows into the tank up to the level of the siphon, the tank will flush automatically.

10.7.15 The Barometer

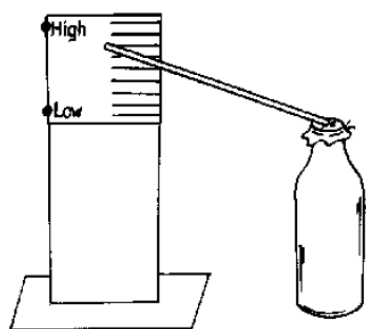

Materials: Bottle, plastic bag, string/rubber band, straw, glue, cardboard, pen

Procedure: Close a bottle air-tight using a piece of plastic bag and string/rubber band. Glue the straw onto the middle of the plastic and point it to a vertical scale written on paper or cardboard.

Theory: When the air pressure increases, it pushes downward on the plastic and the straw dips down. When the air pressure decreases, the relatively high pressure inside the bottle pushes the plastic up, raising the straw.

10.7.16 Madgeburg Hemisphere

Materials: 2 equal size cooking pots, oil, matches, small pieces of paper

Setup: Spread oil or grease around the edge of one of the cooking pots.

Procedure: Place small papers in the un-greased pot and light them on fire. Allow them to burn about half way and then cover with the greased pot so that no air can escape. Allow the pots to cool and try to separate them.

Observations: After the pots have cooled it is very difficult to separate them.

Theory: When you burn the paper, the air in the pot expands and escapes. When you cover the pots, no more air can enter and the air inside cools, reducing the pressure inside the pots while the pressure outside the pots remains the same. The atmospheric pressure therefore presses the pots together so as to equalize the pressure on either side.

Applications of Atmospheric Pressure

10.7.17 The Siphon

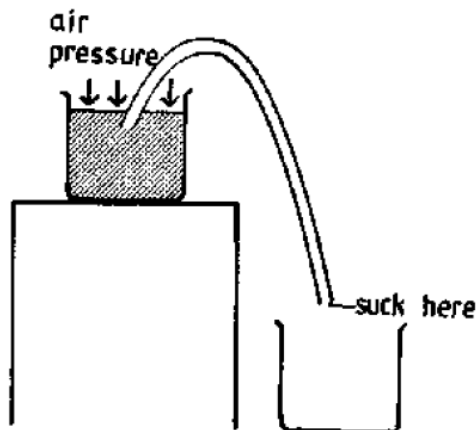

Materials: 2 containers/bottles, Delivery Tube, (1 m), water

Procedure: Place one bottle full of water on a table and the other below. Place one end of the tubing into the water and suck on the other end until water starts coming out. Place this end of the tube into the empty bottle and observe what happens.

Hazards: Clean off the tube thoroughly between uses.

Observations: The water continues to flow to the empty bottle despite an initial uphill climb.

Theory: Sucking on the tube creates a low pressure on that end. The higher atmospheric pressure on the water end causes the water to flow from high pressure to low pressure, overcoming gravity.

Applications: Toilets, drainage systems, Automatic Flushing Tank

Notes: Alternatively, submerge the entire tube initially, then pinch on end and remove from the water. Upon releasing the pinched end outside of the water, the water will flow.

10.8 Work, Energy and Power

Work

10.8.1 Work Done by Lifting

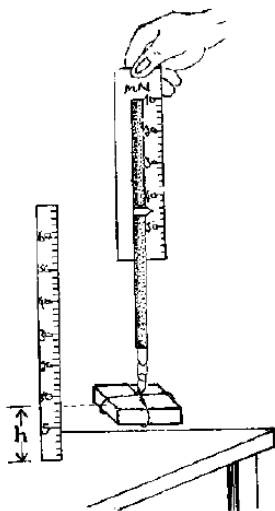

Materials: Spring Balance, block of wood, ruler

Procedure: Raise a block of wood from a table using a spring balance. Read the balance while lifting at *constant velocity*, not when starting or stopping. Compare this to the weight of the block. Measure the vertical distance raised h .

Theory: Work done = Weight $\times h$

10.8.2 Work Done by Friction

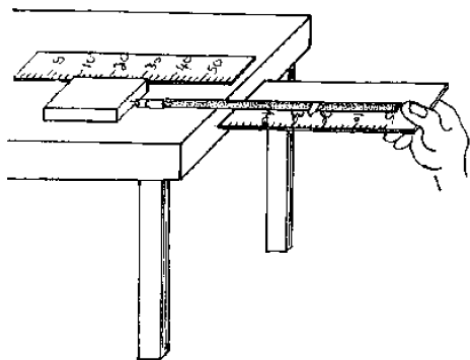

Materials: Spring Balance, block of wood, ruler

Procedure: Place the block of wood on a table and pull with constant velocity using a spring balance. Measure the distance moved by the block.

Theory: Because the block is moving at constant velocity (no net force), the force which pulls the block is equal to the force of friction and opposite in magnitude. Thus, Work done = Force of friction $\times x$

Energy

10.8.3 Forms of Energy

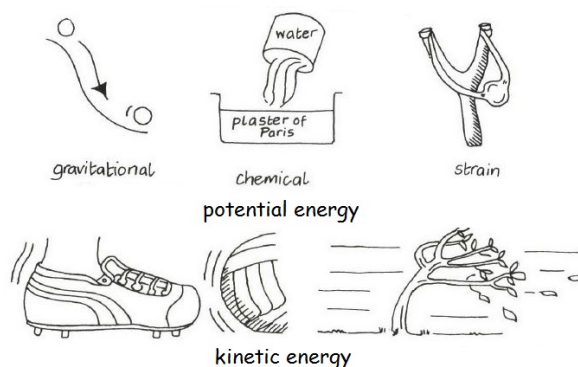

Theory: Energy can take many forms, including potential, kinetic, chemical, heat, sound and electrical. *Potential energy* is energy which is stored in some medium, e.g. spring or battery. *Kinetic energy* is energy in motion, e.g. football or running person.

Applications: What other examples of energy can be found in our daily lives?

10.8.4 A Slingshot

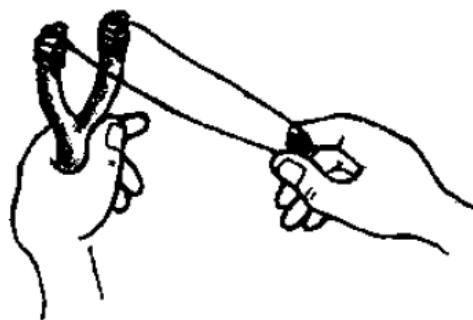

Materials: Rubber band, branched stick, stone

Procedure: Tie either end of a rubber band to the branches of the stick. Place a stone in the middle of the band, pull back and release.

Hazards: Aim the slingshot away from all people.

Theory: The rubber band stores potential energy when stretched, which is transferred to the stone as kinetic energy upon release.

Notes: Conduct an experiment to determine the relationship between stretched length of the rubber band and distance traveled by the stone.

10.8.5 Potential Energy of a Clothespin

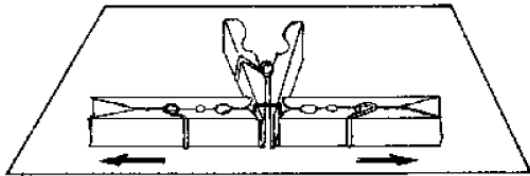

Materials: Three clothespins, scissors

Procedure: Tie the handles of a spring clothespin together with one loop of string. Place it in between two other clothespins on a flat table as shown. Cut or burn the string.

Observations: The two clothespins on either side fly off in opposite directions.

Theory: The spring in the clothespin stores potential energy which is released when the string is cut. This energy is converted into kinetic energy, seen by the movement of the other clothespins.

10.8.6 The Steam Engine

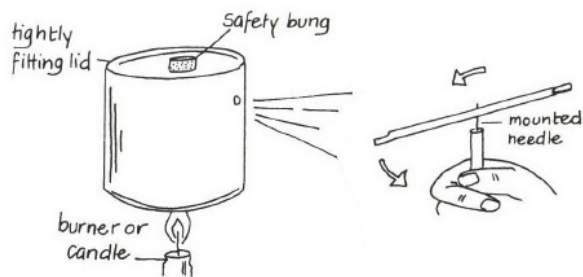

Materials: Tin can with lid, pin, cork, Heat Source, 2 straws

Setup: Poke a small hole near the top of the tin can. Make sure the lid fits tightly, but has a safety bung (i.e. cork). Mount a straw on a pin so that it may spin freely.

Procedure: Fill the can half way with water and heat until boiling. Hold the straw spinner near the hole in the tin.

Hazards: Make sure the safety bung is not too tight and that the tin is not filled with water.

Theory: The candle or burner transfers heat energy to the tin and hence water. This heat energy in the water molecules is converted to kinetic energy as they are forced out of the tin hole. This mechanical energy is transferred to the spinner and makes it turn.

Applications: Mount the steam engine to a small raft and place in water to make a steam boat.

10.8.7 The Simple Pendulum

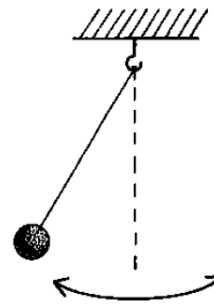

Materials: Stone, string

Procedure: Suspend a stone on a long string and hang from a table. Displace the pendulum to one side and release.

Observations: The pendulum swings back and forth at near regular intervals.

Theory: When the pendulum is released from one side, it has a maximum height and hence potential energy (P.E.), but no kinetic energy (K.E.). When it reaches the low point of its swing, it has maximum velocity and hence K.E., but its P.E. is a minimum. Thus the pendulum's energy is constantly being converted between P.E. and K.E.

Power

10.8.8 Stair Power

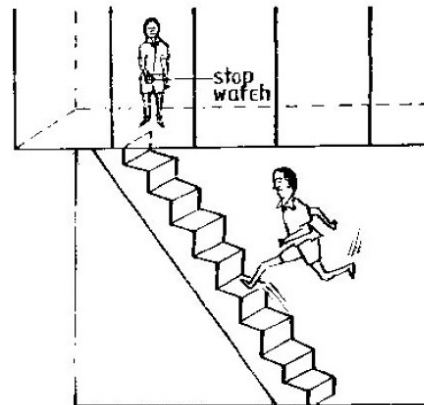

Procedure: Measure the vertical height above ground of the first floor of a building. Run up to that floor as fast as you can while your friend times you with a watch. Take your weight.

Theory: Using your weight and the height of the first floor above ground, first calculate the potential energy (PE) of your body when it is on the first floor ($PE = \text{weight} \times \text{height}$). This is the energy given out in order to raise your body to that height. Now calculate your power by dividing that energy by the time (in seconds) you needed to run up.

10.9 Light

Propagation of Light

10.9.1 Light Travels in a Straight Line

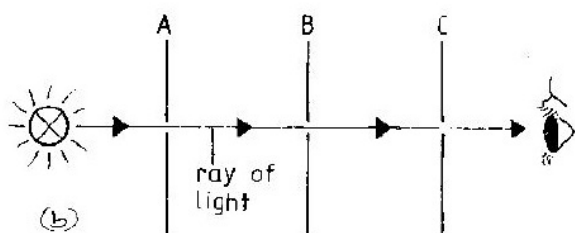
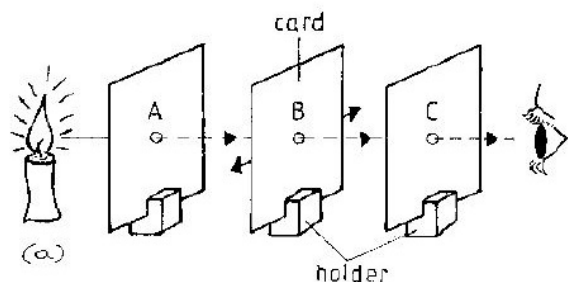

Materials: Candle, cardboard/3 toilet paper tubes, nail, string

Setup: Cut 3 rectangular pieces of cardboard or use 3 toilet paper tubes. Poke a hole at the center of each using a nail. The holes should all be equal distance from the bottom.

Procedure: Arrange the cardboard pieces in a straight line - pass a string through the holes and pull tight to do this. Place the candle or light source near card A and look through card C. Displace any of the 3 cards and look again.

Observations: The light can be seen when all holes are in a straight line, but not when any card is moved.

Theory: Light travels in a straight line. The ray of light cannot be seen through card C when there is an obstruction in its path. Figure (b) shows the *ray diagram* for the path of the light.

10.9.2 Light Through a Comb

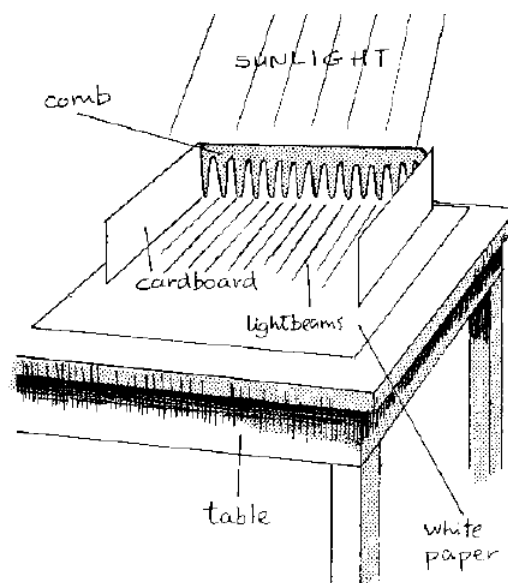

Materials: Comb, light source, paper, cardboard

Procedure: Hold a comb on a white paper placed on a table near a window. Place cardboard on either side of the comb.

Observations: Parallel beams of light can be seen on the paper.

Theory: Light travels in a straight line, so beams of sunlight passing through the slits in the comb appear in parallel lines on the paper.

10.9.3 Ray Boxes

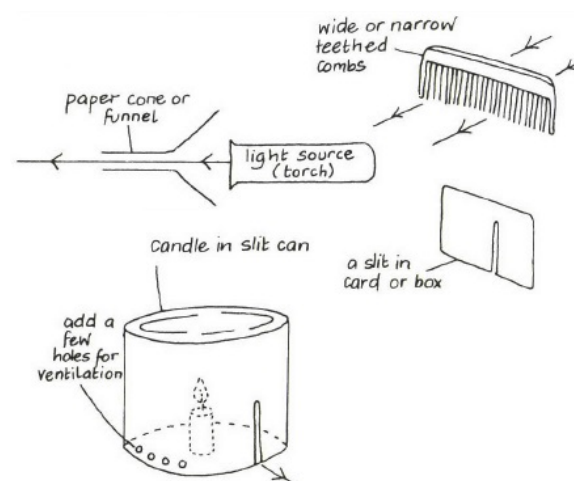

Materials: Torch, paper funnel, comb, card, tin can, candle

Procedure: Many experiments with light require thin beams of light. Make a ray box using one of the methods shown.

10.9.4 Pinhole Camera

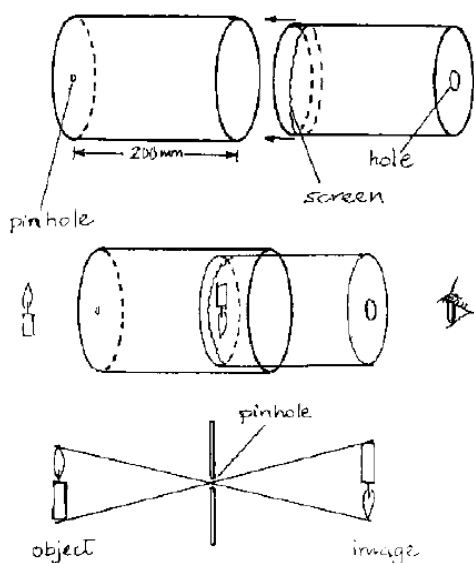

Materials: Tin/cardboard box/manila paper, glue, pin, candle

Setup: Roll a piece of manila paper to make a cylinder. Glue a circular piece of card on one end and poke a hole with a pin. Make a second cylinder to fit tightly in the first. Cover one end with plain paper to act as a screen, and close the other end with a card. At the center of the card make a large 2 cm diameter hole.

Procedure: Observe a burning candle by looking through the large hole. Adjust the inner cylinder to get a sharp image. Adjust the distance between screen and pinhole, as well as between candle and pinhole.

Observations: The image of the candle is real and inverted. When the distance from screen to pinhole is increased, the image becomes larger and more blurred. When the candle is closer to the pinhole, the image gets smaller and sharper.

Theory: The rays of light from the candle cross at the pinhole and thus show up on the screen as an inverted image.

10.9.5 Transparent, Translucent, Opaque

Materials: Piece of glass/clear plastic, book, paper, oil

Procedure: Hold a clear sheet of glass or plastic up in the light. Hold up a book. Rub some cooking oil on a sheet of paper and hold it up.

Theory: The glass/plastic is *transparent* - it allows light to pass through it. The book is *opaque* - light does not pass through it. The oily paper is *translucent* - it allows some light to pass through it.

10.9.6 Formation of Shadows

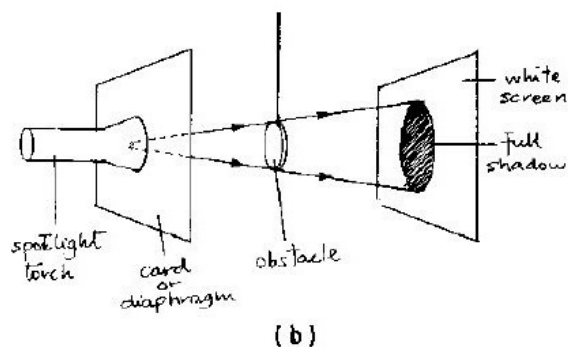
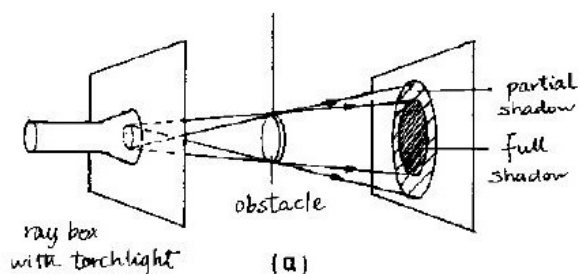

Materials: Torch, cardboard, obstacle (e.g. bucket lid)

Procedure: Place a torch light behind a piece of cardboard with a large hole in it. Hold an obstacle in front of the light (a). Change the hole to a very small size and note the shadow formed by the same obstacle on the same screen (b). Repeat in sunlight.

Observations: The large hole produces a partial shadow and full shadow, while the small hole produces a full shadow only.

Theory: Extended light sources give partial shadows (called *penumbra*) and full shadows (called *umbra*), while single point sources give mainly full shadows. Sharper shadows are obtained when an obstacle intercepts parallel rays, i.e. rays from a distant source.

Applications: Though the sun is an extended source, its rays reach the earth parallel and therefore produce sharp shadows.

Reflection of Light

10.9.7 Laws of Reflection

NECTA PRACTICAL

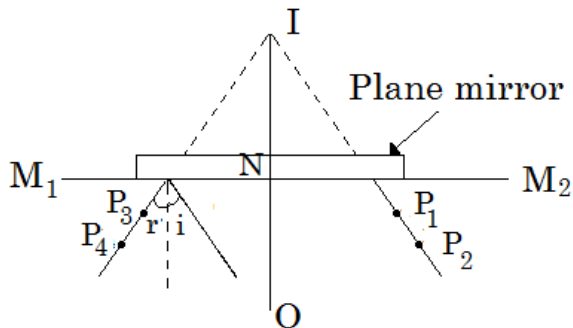

Materials: Plane mirror, pins/syringe needles, paper, ruler, protractor

Setup: Attach a plane mirror to a block of wood.

Procedure: Stand up the mirror and trace a straight line along its base. Place a pin at O a few cm from the mirror. Look at the mirror from the right side and place two pins P₁ and P₂ so that they appear in a straight line with the image. Repeat for the left side using pins P₃ and P₄. Remove the mirror and pins and join the straight lines to meet at I behind the mirror.

Questions: Measure and compare the distances ON and NI using a ruler. Measure angles i and r with a protractor.

Observations: The distances ON and NI are equal. The angles i and r are equal.

Theory: The laws of reflection for a plane mirror state that: (1) object distance (ON) and image distance (NI) are equal; and (2) the angle of incidence (i) and angle of reflection (r) are equal.

10.9.8 Reversed Image

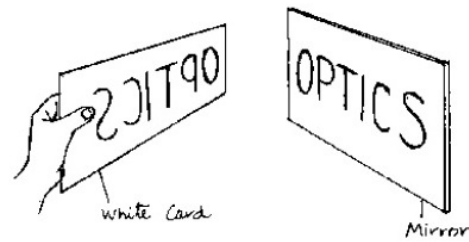

Materials: Paper, mirror, pen

Procedure: Write the word OPTICS on an ordinary piece of paper. Turn the paper and retrace the faint word appearing on its back. Place the paper in front of a plane mirror.

Theory: Mirror images are reversed images, i.e. the left and right side of the object are interchanged.

10.9.9 Images Formed in Multiple Mirrors

NECTA PRACTICAL

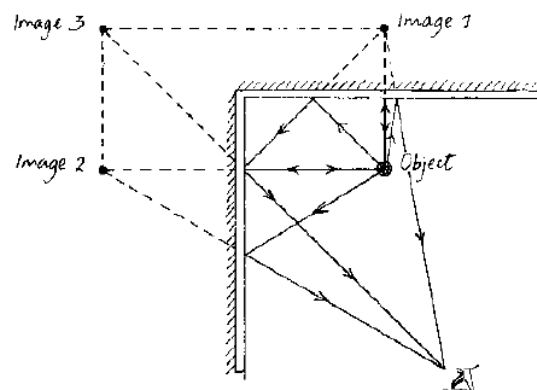

Materials: 2 plane mirrors, pin, paper, protractor

Procedure: Place two mirrors upright at right angles to each other. Place a pin (Object) in between them. Look at the mirrors and count the number of images seen. Repeat with mirrors at angles of 60° and 45°.

Questions: How many images can be seen in each case?

Observations: At right angles, 3 images are produced; at 60°, 5 images; and at 45°, 7 images.

Theory: For an angle θ between the mirrors, the number of images produced n follows the relationship $n = \frac{360^\circ}{\theta} - 1$.

Applications: Kaleidoscope

Applications of Reflection

10.9.10 Periscope

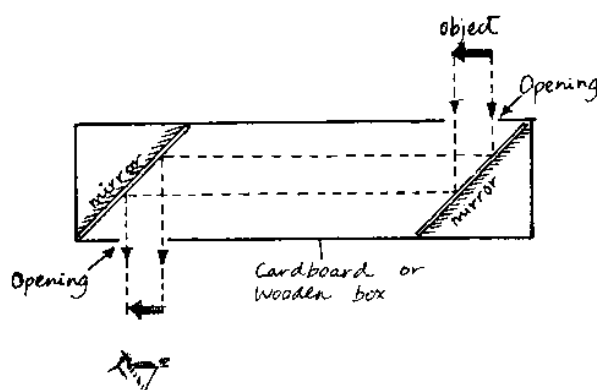

Materials: 2 mirrors, rectangular box, glue/tape, scissors

Setup: Arrange two mirrors in the box as shown. The mirrors should be at 45° angles to the walls.

Procedure: Look through the periscope to view objects above walls and around corners.

Observations: Images produced are upright.

Applications: Submarines

10.9.11 Kaleidoscope

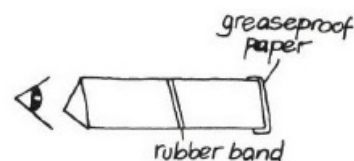

Materials: 3 mirrors of equal size, tape, cardboard, rubber bands, coloured objects (optional)

Setup: Tape the 3 mirrors together so that they form a triangular tube with the reflective sides facing inwards. Wrap them in cardboard and fix with rubber bands.

Procedure: Look through the kaleidoscope at any objects, especially coloured beads or paper, and turn to watch the colors change.

Physics Activities for Form II

11.1 Static Electricity

Concept of Static Electricity

11.1.2 Law of Electrostatics

11.1.1 Paper Jump

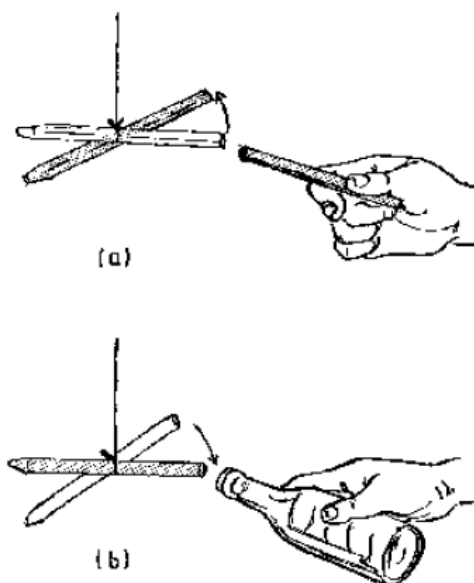
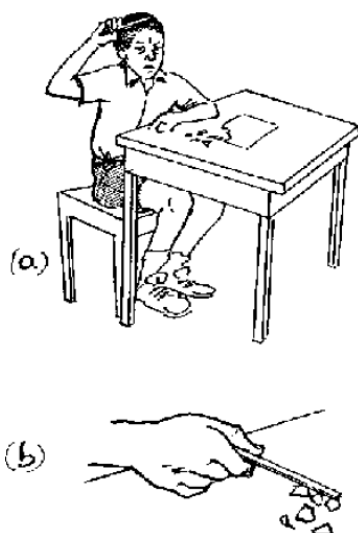

Materials: Small pieces of paper, ruler, pen, balloon, salt and pepper (optional)

Procedure: Rub a pen, ruler or blown up balloon against your hair for about 30 seconds. Then bring it close to the small papers on a table.

Observations: The small papers jump and cling to the object.

Theory: When you rub the object against your hair, electrons are transferred by friction to the object, giving it a negative charge. When the negatively charged object approaches the papers, the electrons in the papers are repelled downwards and the protons are attracted towards the top. When the object is close enough the positive charges on the tops of the papers jump and cling to the negatively charged object.

Notes: Try also with salt and pepper. The pepper jumps but the salt is too heavy and does not.

Materials: Plastic pens, wool cloth, sting, glass bottle, silk cloth (inside of a suit)

Procedure: Rub a plastic pen on your hair and bring it near a suspended pen charged in the same way. Repeat by bringing a glass bottle charged with silk or polyester near the suspended charged pen.

Observations: The two charged pens repel each other, but the glass bottle attracts the charged pen.

Theory: *Like charges repel and unlike charges attract.* The two pens are negatively charged after gaining electrons from the hair. The glass bottle is positively charged after giving up electrons to the silk.

11.1.3 Electrostatic Induction

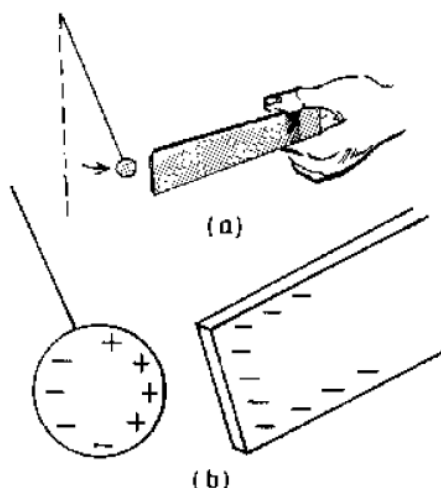

Materials: Ruler, aluminum foil, string

Procedure: Crumple a piece of foil into a ball and suspend it from a string. Charge a ruler by rubbing on your hair and bring it close to the foil ball without touching it.

Observations: The aluminum ball is attracted by the charged plastic ruler.

Theory: The negatively charged ruler repels the electrons in the foil ball and attracts the protons, creating an induced *dipole* in the ball. This is called *electrostatic induction*.

Notes: Try different materials such as rubbing plastic on nylon, glass on silk, or latex on fur.

11.1.4 Water Pull

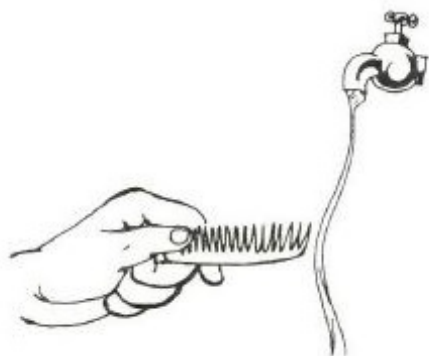

Materials: Comb, water stream or tap

Procedure: Rub a comb in your hair for about a minute. Then bring the comb close to a narrow stream of water from a tap or bottle.

Observations: The water is pulled towards the comb.

Theory: The comb gains electrons from the hair and becomes negatively charged. The protons in the water molecules are attracted to the electrons in the comb. The water is said to have an *induced dipole*.

11.1.5 Charged Balloon

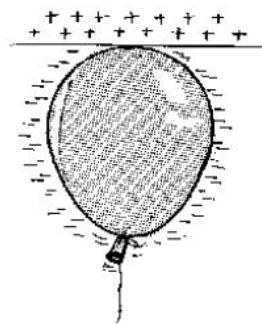

Procedure: Rub a balloon on a wool cloth or hair and then place it against the ceiling.

Observations: The charged air balloon sticks to the ceiling.

Theory: The negative charge on the balloon repels some of the electrons in the ceiling away from the surface. This leaves the surface positively charged and so the negative balloon is attracted by the ceiling.

Notes: The experiment should be carried out during dry weather.

Electroscope

11.1.6 Simple Electroscope

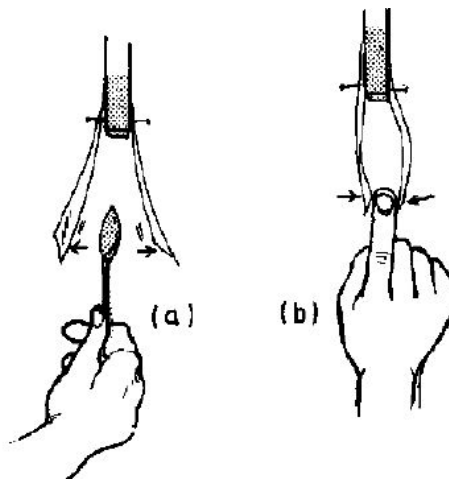

Materials: Plastic strips, duster, plastic spoon

Setup: Cut two strips of plastic and fix to a piece of wood. Charge the strips by rubbing with a clean duster.

Procedure: Bring a charged plastic spoon between the charged strips and then your finger.

Observations: The charged strips are repelled further by the charged spoon, but attracted to the finger.

Theory: The finger attracts the strips because the body is earthed, so it becomes positively charged relative to the two negatively charged strips.

11.1.7 Construction of a Simple Electroscope

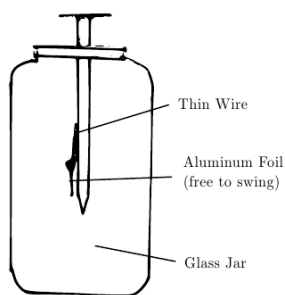

Materials: Clear jar with a plastic cap, iron nail, small piece of aluminium foil, glue, ruler or glass and silk

Setup: Insert the nail into the cap so that about 1 cm remains above the top. Use glue to secure it in place. Cut a piece of aluminium foil 0.5 cm by 2 cm. Glue one end of the foil (only the tip) to the nail about 2 cm from the bottom. Bend the foil so it can swing easily. Close the cap with the nail and foil.

Procedure: Bring a charged object near the nail and notice any deflection in the leaf.

Observations: The leaf deflects from the nail.

Theory: The charged object repels the opposite type of charge in the nail, which moves down the nail and into the leaf. The like charges on the nail and leaf repel each other, causing a deflection to occur.

11.1.8 Simple Detector

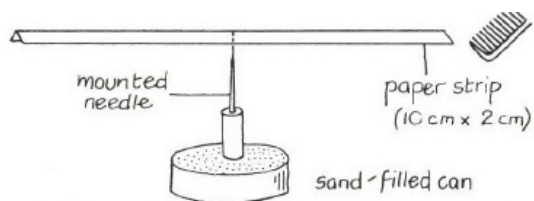

Materials: Paper, needle/pin, sand-filled can, ruler

Setup: Mount a strip of paper 10 cm by 2 cm on a needle supported by a sand-filled can.

Procedure: Bring a charged object (ruler or pen rubbed on hair or glass rubbed with silk) close to the paper.

Questions: Which way does the paper move for different charged objects?

Theory: The paper will deflect when a charged object is brought near due to induction. Any charge on the paper can be detected based on whether it is attracted to the object (same charge) or repelled (opposite charge).

Capacitors

11.1.9 Paper Capacitor

Materials: Aluminum foil, paper, dry cell, voltmeter, wires, tape

Setup: Cut 2 sheets of aluminum foil (e.g. 20 cm \times 20 cm).

Procedure: Place several sheets of paper between the foil sheets. Connect each foil sheet to a terminal of the dry cell using tape. Connect a voltmeter across the foil sheets.

Observations: The foil sheets become charged by the battery and show a small potential difference on the voltmeter.

Theory: *Capacitors* are devices that store charge between two conducting plates. Placed between the plates is an insulating material known as a *dielectric*. The capacitance of a capacitor depends on the surface area of the conducting plates, the distance between them, and the dielectric material.

11.2 Current Electricity

Simple Electric Circuits

11.2.1 Conductors and Insulators

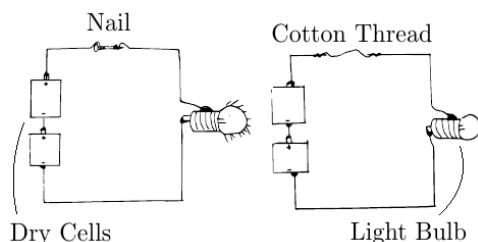

Materials: Dry cells, light bulb, speaker wire, cardboard, various materials (e.g. nail, pen cap, aluminum foil, string, balloon, toothpick, bottle cap, pencil, etc.)

Setup: Connect the dry cells and light bulb using speaker wire and leave two ends of the wire free.

Procedure: Have students predict which materials will cause the bulb to light. Then try them one by one by placing them across the free wire ends.

Observations: Metal objects such as nails, aluminum foil, bottle caps, etc. turn on the light, while others do not.

Theory: *Conductors* allow electric current to pass through them easily, while *insulators* do not. Placing conducting materials (e.g. many metals) across the wires closes the circuit and allows electrons to flow through the bulb and produce light.

11.2.2 Student Circuits

Setup: Make a square or circular pathway using chairs/tables as boundaries on either side. Place sheets of paper with “+” and “-” written on them on one table. Place several obstacles (e.g. stools, stacks of books, etc.) throughout the path.

Procedure: Have students walk in one direction (from + to -) through the track. After some time, place a large obstacle (e.g. desk) at some point to block off the path.

Theory: The path represents an electric circuit. The students (electrons) move around the path from the positive terminal to the negative terminal, but their motion is impeded by the obstacles (resistances). Placing the table to cut off the path represents a switch which prevents the flow of the electrons.

11.2.3 Creating a Light Bulb

Materials: Glass jar with lid, glue, wires, power source, thin iron wire, nail

Setup: Use the nail to poke two holes in the jar lid. Pass a wire through each hole half way into the jar. Connect the wires inside the jar with the iron wire. Seal the wires into the lid with glue and close the lid on the jar.

Procedure: Connect the wires outside the jar to the power source.

Observations: If enough current is passing, the iron wire will light up, creating a light bulb for a short time until the wire burns out.

Theory: Electricity can be used to generate light as a result of resistance in a wire.

Questions: Why do bulbs eventually stop working? What other materials produce light when heated?

Notes: You may need to try different types of wire for the bulb. It should be very thin and have a high resistance.

Ohm's Law

11.2.4 Verifying Ohm's Law

NECTA PRACTICAL

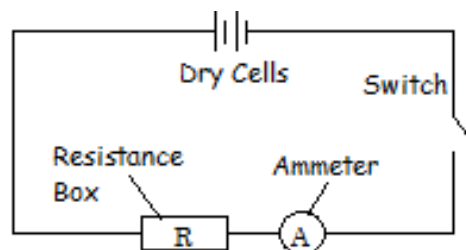

Materials: Dry cells, speaker wire, resistance box/rheostat, ammeter/galvanometer

Setup: Connect the circuit as shown.

Procedure: Adjust the resistance box/rheostat to give $1\ \Omega$. Read the current I on the ammeter. Repeat for different resistances ($2\ \Omega$, $3\ \Omega$, $4\ \Omega$, $5\ \Omega$).

Questions: Tabulate values of R and I . Plot a graph of resistance, R (vertical) against $\frac{1}{I}$ (horizontal). Find the slope of the graph.

Observations: As the resistance increases, the current decreases.

Theory: Ohm's Law tells us that potential difference in a circuit is directly proportional to the current passing through it ($V = IR$). Solving this equation for R gives $R = \frac{V}{I}$, so the slope of the graph represents the voltage V .

Electrical Components

11.2.5 Circuit Boards

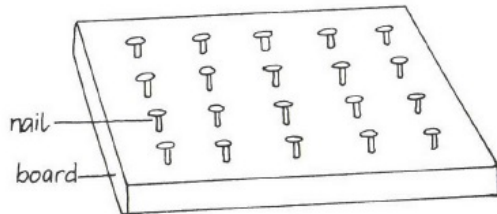

Materials: Wood board, nails

Setup: Make a grid of nails in the board as shown.

Procedure: Use the nails to connect different circuit components. Gaps between nails can serve as a switch.

11.2.6 Switches

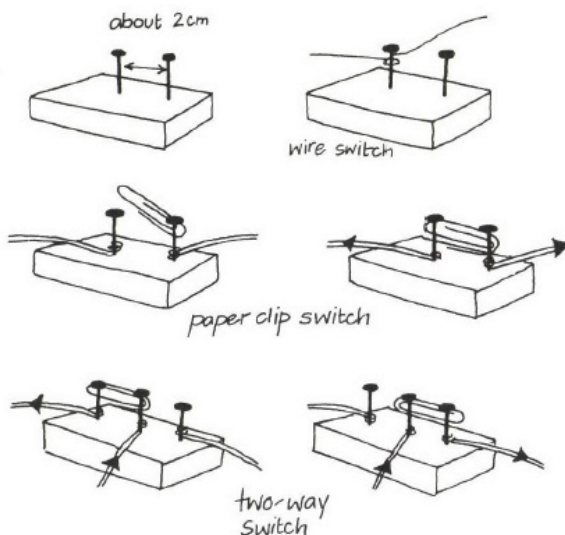

Materials: Nails, small wooden blocks, paper clips, speaker wire

Procedure: Assemble the various switches shown and use them to connect circuit components.

11.2.7 Rheostat

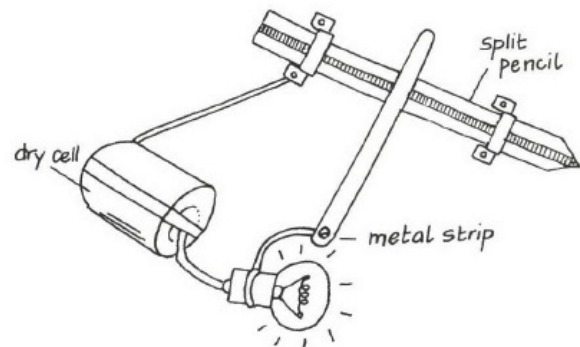

Materials: Dry cell, metal strip, pencil, wire, bulb

Procedure: Cut a pencil in half so that its graphite center is showing. Connect a dry cell, bulb and metal strip as shown. Move the metal strip along the graphite in the pencil.

Observations: When the metal strip is moved to the left along the graphite of the pencil, the bulb burns more brightly.

Theory: The graphite acts as a resistor. Its resistance depends on its length, so when a shorter distance is used in the circuit, there is less resistance and the bulb burns more brightly.

11.2.8 Finding Circuit Components

Materials: Old or broken electronics (radio, car stereo, computer, phone charger, disc drive, etc.), pliers, screw driver, soldering iron (optional), empty matchboxes

Setup: Ask local community members/fundis/repair shops for old or broken electronics.

Procedure: Identify common components inside the devices and place them in separate containers (matchboxes). Pliers or a soldering iron may be necessary to remove some components.

Hazards: If using a soldering iron, do not touch the tip as it can quickly cause second degree burns. NEVER open a component which is connected to a power source!

Observations: You should be able to find a variety of resistors, capacitors, wires, motors, rheostats, switches, diodes, transistors, transformers, speakers, inductors, bulbs, etc.

Notes: Have this be an ongoing activity for your school. Keep looking for more things to take apart.

Water Analogies

Switches

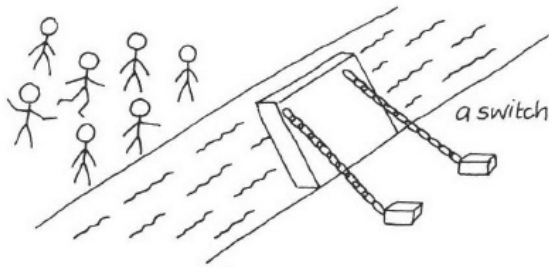

The drawbridge acts as a switch.

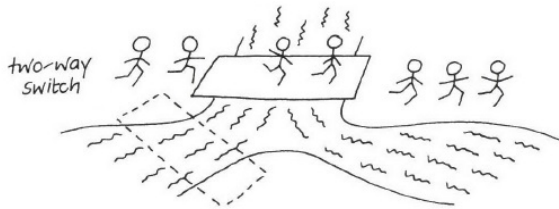

The plank can only be in one of two positions. It is analogous to a two-way switch.

Circuits in Series

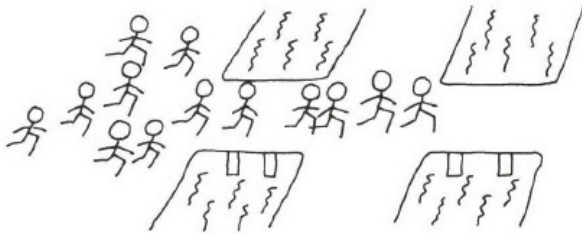

If the bridge breaks, the flow stops, i.e. if one component breaks, the circuit is incomplete and electricity cannot flow.

Circuits in Parallel

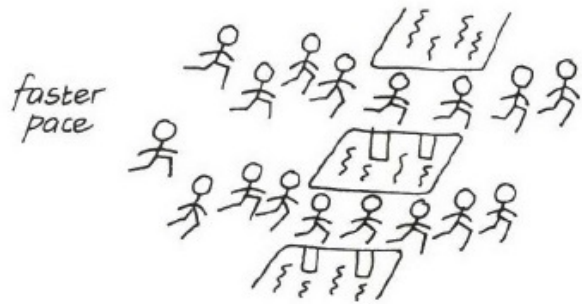

If one bridge breaks the race can go on, i.e. if one component fails there is still an alternative route for the electricity to flow.

Electricity



The river (electricity) flows through the narrow and the wide part of the river. However, where the river is narrow the amount of water flowing (the current) is smaller, but the resistance or power is greater, while the voltage stays the same.

A dam acts like a switch. Unless the dam is opened no water can flow.

11.3 Magnetism

Concept of Magnetism

11.3.1 Magnetic and Non-magnetic Materials

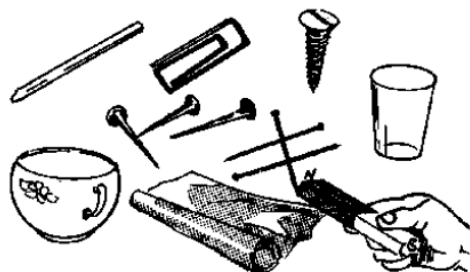

Materials: Magnets, various local objects e.g. nails, plastic, wood, cloth, copper, iron, aluminium, etc.

Procedure: Bring a magnet close to each of the materials listed above.

Questions: What happens to each material?

Observations: Some materials such as nails and paper clips are attracted to the magnet, while others like toothpicks and plastic are not.

Theory: Materials that are attracted by magnets are called *magnetic materials*, while those that are not attracted to magnets are called *non-magnetic materials*.

Properties of Magnets

11.3.2 Interaction Between Magnets

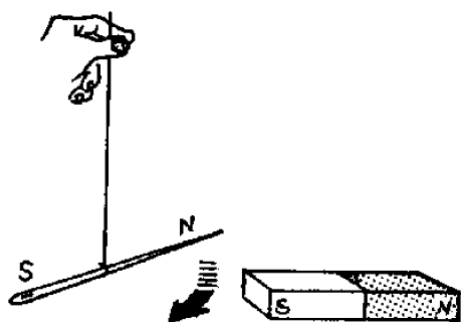

Materials: 2 magnets or magnetised needles

Procedure: Suspend one magnet or magnetised needle and bring the other close to it. First try N-pole to N-pole, then N-pole to S-pole, and so on.

Observations: When two N-poles or two S-poles are placed near each other, the pin deflects away from the magnet, but when an N-pole and S-pole are near together, they attract.

Theory: Like poles repel, unlike poles attract.

Magnetisation

11.3.3 Stroking Method

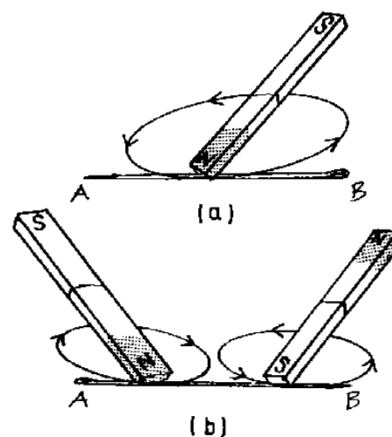

Materials: Magnet, needle

Procedure: Move one pole of a bar magnet many times along the needle as shown in (a). Now take another needle and move the magnet as shown in (b), starting from the middle.

Observations: The needle in (a) has a N-pole at A and S-pole at B, while the needle in (b) has a S-pole at A and a N-pole at B.

Theory: The first needle is magnetised by the single touch method, and the second is magnetised by the double touch method.

11.3.4 Electromagnet

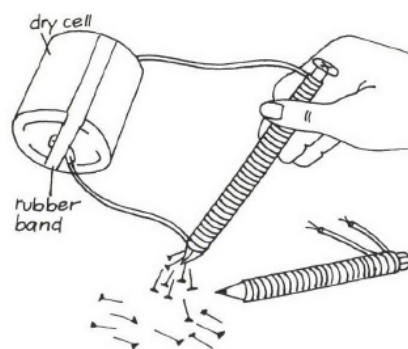

Materials: Dry cell, nail, insulated copper wire, pins

Procedure: Make about 50 turns of wire around the nail. Connect the wire to the dry cell. Pick up the pins with the magnetised nail.

Theory: The nail is magnetised by the electrical method. The moving electric charge in the wire solenoid creates a magnetic field in the nail. Strength of the magnet depends on the number of turns and current.

Demagnetisation

11.3.5 Demagnetisation of a Magnet

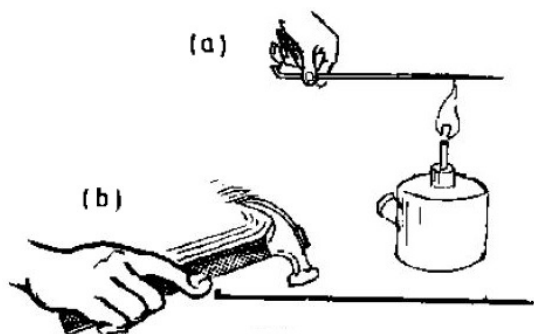

Materials: Magnetised needles, paper clips, hammer, [Heat Source](#)

Procedure: Take two magnetised needles. Check to make sure they attract paper clips. Heat one needle in a flame (a) and hammer another several times (b). Check if the needles still retain their magnetism.

Observations: The magnetism of the needles is lost.

Theory: Magnets should not be kept in hot places or dropped or they may lose their magnetism.

Magnetic Fields

11.3.6 Magnetic Filings

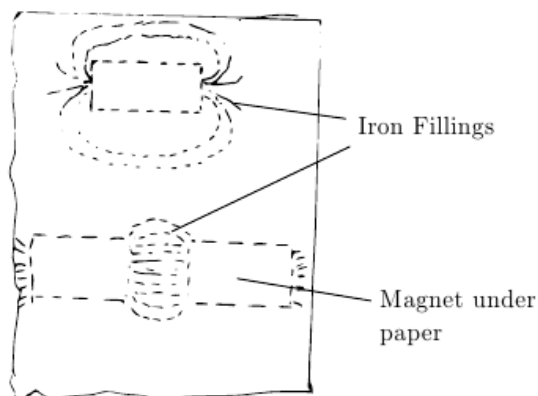

Materials: Bar magnets, paper, steel wool

Procedure: Place one or two bar magnets under a sheet of paper. Sprinkle iron filings over the top to reveal the lines of the magnetic field.

Theory: Filings gather around the poles, where the magnetic force is strongest. Lines of repulsion are seen for like poles, and there is a *neutral point* in the center through which no lines pass. Lines of attraction are shown for unlike poles.

11.3.7 Simple Compass

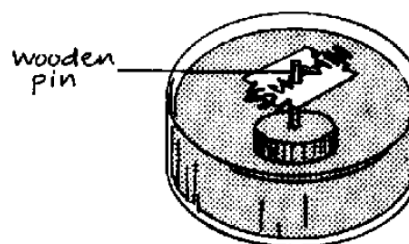

Materials: Bowl filled with water, wooden pin, magnetised razor blade

Procedure: Fix a wooden pin vertically in a bowl of water. Slip a magnetised razor blade along the pin and carefully place it on the surface of the water so that it can rotate. Gently rotate the bowl and then the razor blade and observe what happens.

Observations: When the bowl is rotated, the razor blade continues to lie in the N-S direction. When rotated itself, it returns to this orientation.

Theory: The magnetised razor blade aligns itself with earth's magnetic field in a N-S direction. As long as it remains magnetised, it will keep this orientation.

11.3.8 Magnetic Dip Gauge

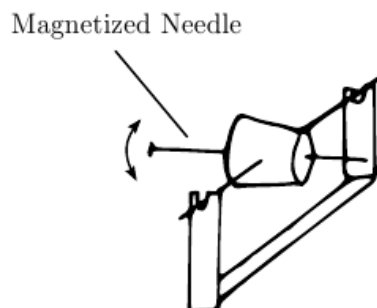

Materials: Magnet, needle, cork/foam, two pins, paper, pen, cardboard or metal strip

Setup: Push the two pins into the ends of the cork to create an axle. Push a needle through the cork perpendicular to the axle. Balance the pins on a U-shaped stand made of cardboard or metal strips.

Procedure: Set the gauge so that the needle is free to rotate vertically. Then magnetise the needle by stroking with a bar magnet.

Observations: Before magnetising the needle, it balances horizontally in equilibrium. When magnetised however, it will dip down to show the direction of earth's magnetic field.

Theory: Like a compass, the needle naturally moves to show the direction of the earth's magnetic field. The gauge only works if facing N-S.

11.4 Forces in Equilibrium

Effect of Turning Forces

11.4.1 Ruler Balance

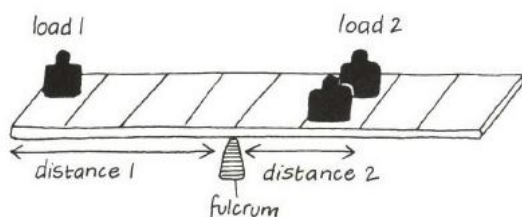

Materials: Ruler, small weights (e.g. coins), fulcrum (e.g. knife or ruler)

Procedure: Balance the ruler on the fulcrum (15 cm mark). Add coins to either side at different distances in order to keep the ruler balanced. Repeat by starting the ruler at the 10 cm or 20 cm marks.

Observations: Larger loads require shorter distances to balance, while smaller loads require longer distances from the fulcrum.

Theory: $\text{Moment} = \text{Force} \times \text{Lever arm}$. In order to balance, the moments on either side of the pivot must be equal. When the lever arm of one side is larger, more weight must be added to the shorter side to balance.

11.4.2 Door Tug-of-War

Procedure: Get two students. One pushes against a door near the hinge and the other pushes in the opposite direction near the handle of the door.

Observations: The student pushing near the handle of the door will find it much easier to push the door her way.

Theory: Moment of a force depends on both the *magnitude of the force* and *length of the lever arm*. The student that pushes farther from the axis of rotation can exert less force, while still producing a greater moment.

11.4.3 Moment of a Door

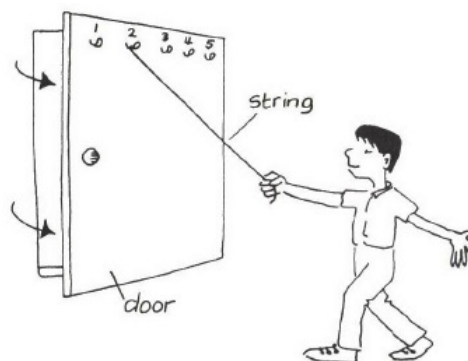

Materials: Hooks/nails, string, door

Procedure: Place the hooks in the door 10-15 cm apart. Attach a string to the hooks, one at a time and try to pull the door open.

Questions: Which hook makes it easiest to open the door?

Observations: The door is easier to open for hooks which are farther from the hinge.

Theory: Increasing the lever arm (distance from hinge) requires a smaller force to generate the moment needed to open the door. A short lever arm requires a larger force to achieve the same moment.

11.4.4 Candle Balance



Materials: Candle, 2 cups, nail, paper

Setup: Cut out the paper figures as shown.

Procedure: Construct a candle balance as shown in the figure.

Observations: The candle ends move up and down like a see-saw.

Theory: The candle ends lose drops of wax in succession which causes a loss in weight at each end.

Principle of Moments

11.4.5 Determining an Unknown Mass

NECTA PRACTICAL

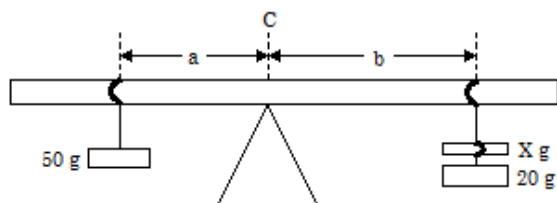

Materials: Metre rule, triangular wooden block, string, dry cell, **Masses** (20 g and 50 g)

Procedure: Balance the metre rule on the wooden block (should be near 50 cm mark). Hang a 50 g mass a distance $a = 5$ cm from the pivot point on one side. Balance the opposite side using a 20 g mass together with the dry cell. Record the length b required to balance the ruler. Repeat for $a = 10$ cm, 15 cm, 20 cm and 25 cm.

Questions: Plot a graph of a against b . Calculate the slope and use it to find the mass of the dry cell, X .

Theory: From the principle of moments, $(50g)(a) = (20 + Xg)(b)$. Canceling g we find that $\frac{a}{b} = \frac{20+X}{50} = \text{slope}$, so the value of X can be determined.

11.4.6 Mass of a Ruler

NECTA PRACTICAL

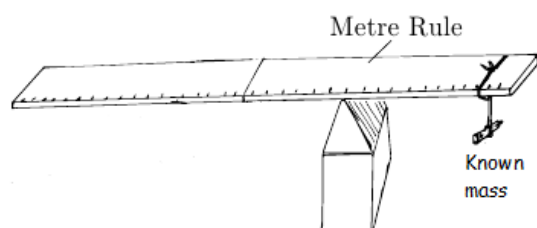

Materials: Metre rule, triangular wooden block, **Masses**

Procedure: Place a known mass on one end of a metre rule. Adjust the position of the ruler until it balances on the knife edge.

Questions: Determine the mass of the metre rule.

Theory: Using the known mass and measured distances on either side of the pivot, the unknown mass of the ruler can be found.

Centre of Gravity

11.4.7 Finding the CoG

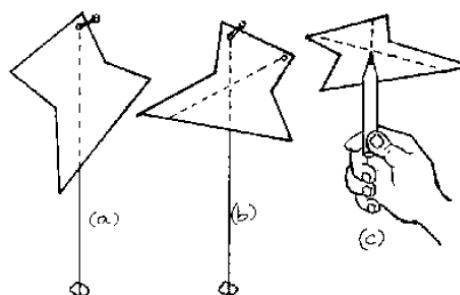

Materials: Manila paper, pen, nail, sting, stone

Procedure: Cut a piece of manila paper into an odd shape. Suspend it from a nail and attach a string with a stone. Mark the position of the string at two points and then connect with a straight line using a ruler and pencil, as shown in (a). Repeat by fixing the nail in another point on the shape (b). Balance the shape at the point where the two lines meet.

Observations: The shape balances at the intersection of the lines.

Theory: The intersection of the two lines locates the *centre of gravity* of the object, and so it balances.

11.4.8 CoG of a Ruler

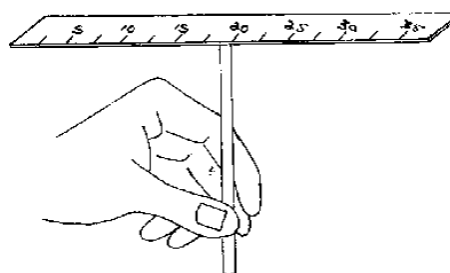

Materials: Ruler, pencil/pen

Procedure: Find the centre of gravity of a ruler by balancing it on the tip of a pencil.

Observations: The ruler balances at its center point.

Theory: The ruler's mass is evenly distributed. Thus, its centre of gravity acts at its geometrical centre.

Types of Equilibrium

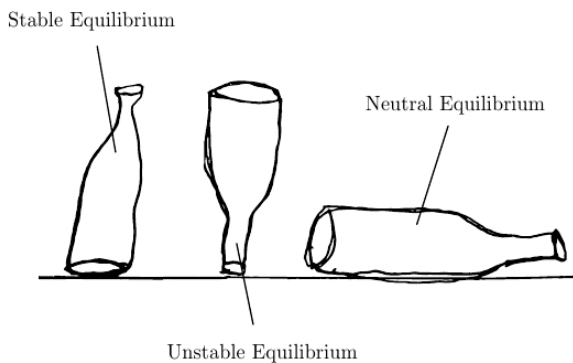

A body is in *stable equilibrium* if a small movement would rise its CoG, *unstable equilibrium* if a small movement would lower its CoG, and *neutral equilibrium* if a small movement would keep its CoG at the same level.

11.4.9 Balancing Forks



Materials: 2 forks, 2 coins, jar/can
Procedure: Take 2 coins and attach two forks as shown in the figure. Balance the arrangement on the edge of a jar or can.
Theory: The CoG of the system is over the balancing surface, so it is in stable equilibrium.

11.4.10 Balancing Nails

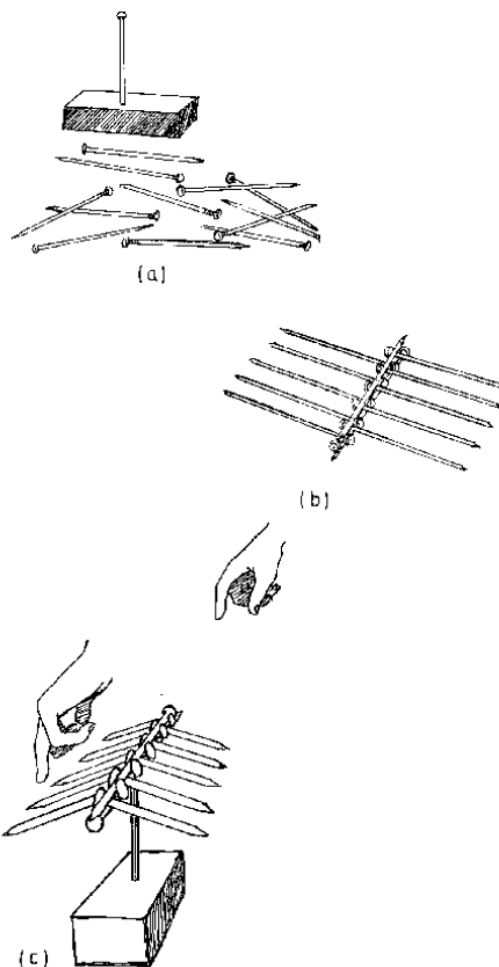

Materials: Nails, piece of wood
Procedure: Stand one nail vertically in a piece of wood. Give students 10-12 nails and tell them to balance them all on top of this one nail.
Observations: Arranging the nails according to figure (b), they can all be balanced.
Theory: The CoG is lower than the supporting head of the first nail, so the entire assembly is in *stable equilibrium* and thus does not fall over.

11.5 Simple Machines

Levers

11.5.1 Ruler Lever

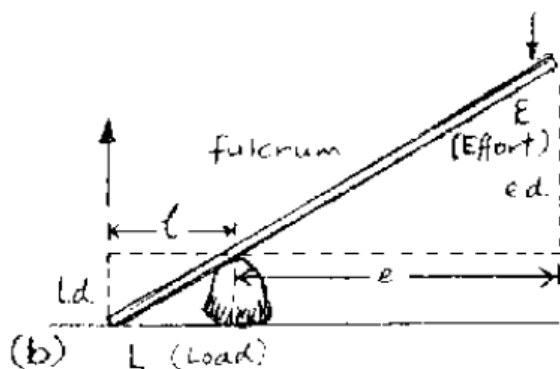
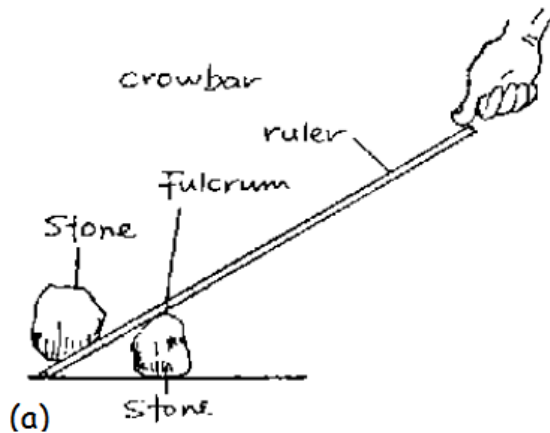

Materials: Ruler, stones

Procedure: Make a lever using a ruler and a stone. Use it to lift a heavy stone or brick.

Theory: The mechanical advantage is greater than one, i.e. the effort is less than the load; but the velocity ratio is greater than one, i.e. the effort distance is greater than the load distance.

Applications: Seesaw, pliers, wheelbarrow, bottle opener, forearm, etc.

Notes: Now slide the ruler down so that the fulcrum is near the center and try to lift the stone. Is it easier or more difficult?

11.5.2 Uses of Levers

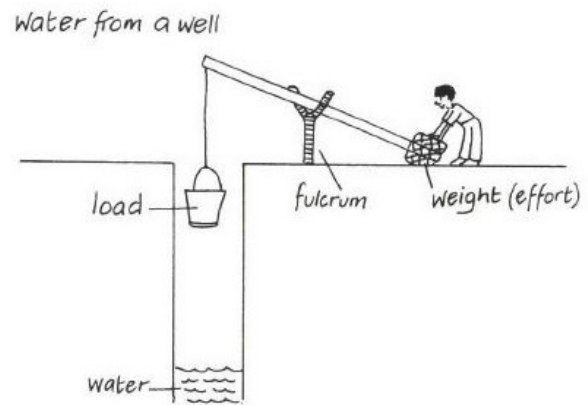

pulling a vehicle out of mud

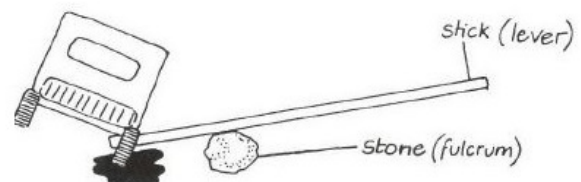

Applications: Levers can reduce the work needed to move loads. Ask students where levers are used in their own communities.

11.5.3 The Seesaw



Applications: The seesaw, pliers, the wheelbarrow, tweezers, the bottle opener, the forearm, the roman steelyard, etc. are all levers.

Pulleys

11.5.6 Single Pulley

11.5.4 Simple Pulleys

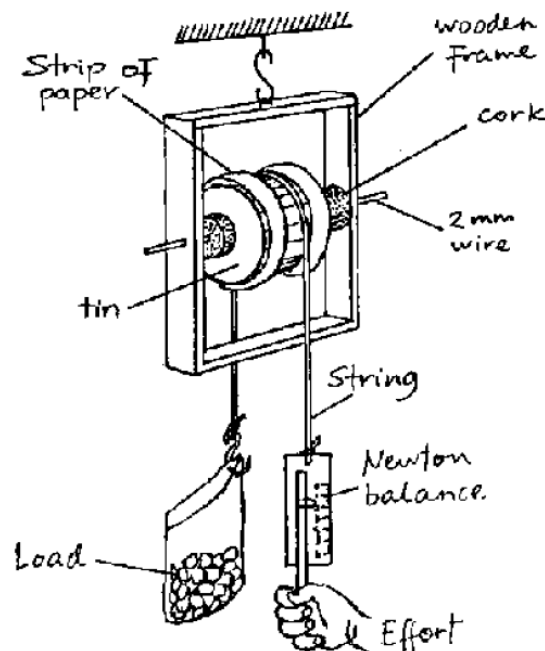
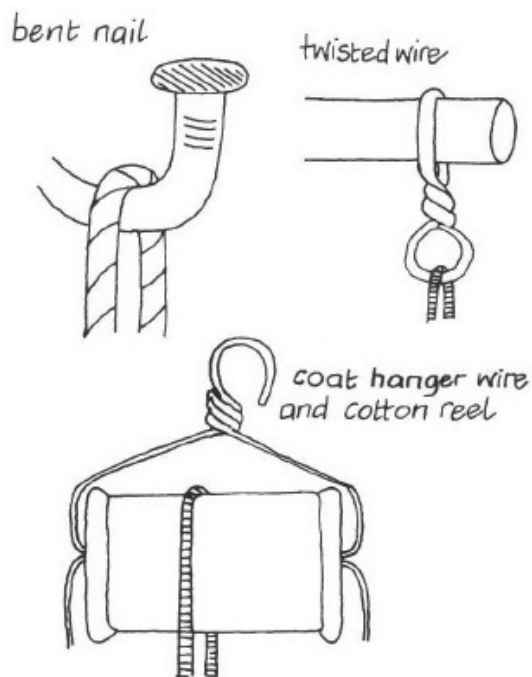

Materials: Nails, wire, coat hanger, water bottle, cotton reel

Procedure: Construct pulleys using any of the methods shown above. Alternatively, cut off the tops of water bottles just below the lip where the cap rests.

Applications: Flagpole, well buckets, construction of tall buildings, etc.

11.5.5 Uses of Pulleys

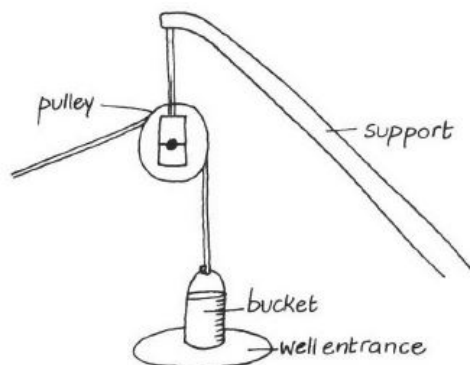

Applications: Ask students where they have seen pulleys used and why they reduce the work of lifting loads.

Materials: Spring Balance, bag of stones, string, stiff wire, thin wood, tin, cork, paper

Setup: Use one of the pulleys above, or construct one by poking holes on either end of a tin and placing a wire as an axle. Fix the axle into a wooden frame as shown.

Procedure: Attach a string to a load much heavier than the pulley (e.g. bag of stones). First measure the weight of the load using a spring balance. Then run the string across the pulley and record the effort required to lift the load.

Observations: The weight of the load and the effort force required to raise it are equal.

Theory: A pulley has a M.A. of 1, meaning the load and effort are the same. The advantage of a single pulley is that it *changes the direction* of the load. It is much easier to lift a heavy load by pulling downwards (with the help of your own weight) than by pulling upwards.

11.5.7 Block and Tackle System

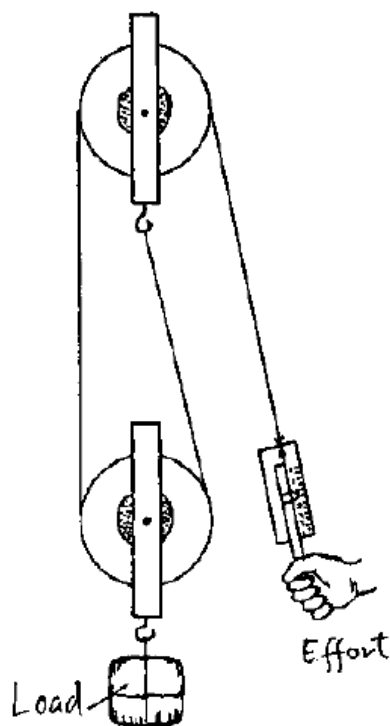

11.5.8 Strength vs. Science

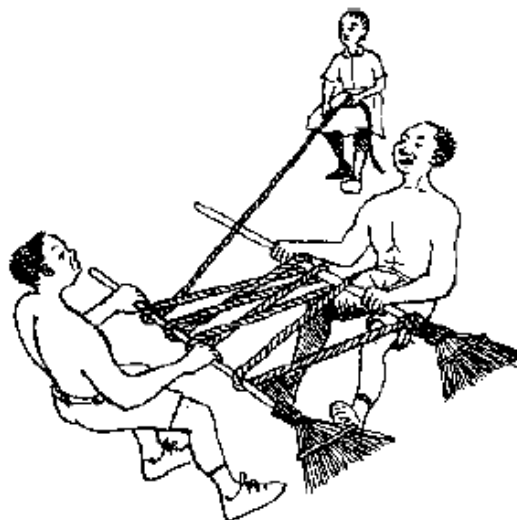

Materials: 2 pulleys, string, [Spring Balance](#), load (bag of stones)

Setup: Connect two single pulleys as shown in the figure, using any of the designs described above.

Procedure: Use this system to lift the same load as in the previous activity. Measure the effort using a spring balance.

Observations: It is easier to lift the load this time, i.e. the effort is smaller.

Theory: Neglecting friction and weight of the pulley, the M.A. will be 2, i.e. the load is twice the effort. The V.R. is equal to the number of pulleys in the system, in this case 2.

Notes: Try with more pulleys and see how it affects the M.A.

Materials: 2 broomsticks/jembe sticks, rope

Procedure: Fix one end of a rope to one stick and wind it back and forth around the two sticks as shown. Have 2 strong students pull on the sticks and one small student pull the other end of the rope.

Observations: The small student wins.

Theory: This is an arrangement of “broomstick pulleys.” The small student requires much less effort to pull the heavy loads of the two strong students. However, the small student will have to move farther than the others.

Inclined Plane

11.5.9 The Ramp

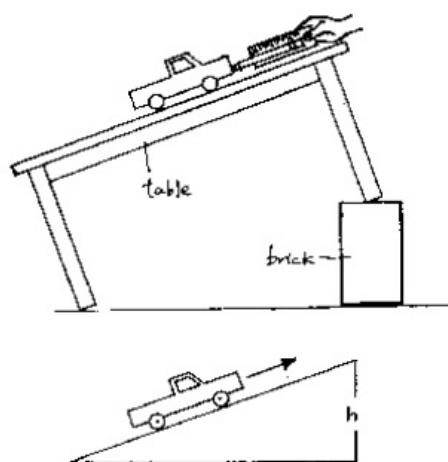

Materials: Table, brick/books, [Spring Balance](#), small weights/toy car

Procedure: Tilt a table by placing a brick or stack of books underneath its legs on one side. Weigh a small object (i.e. toy car) using a spring balance. Now pull the object up the tilted table and measure the effort with the spring balance.

Observations: The effort is smaller than the load (weight of the object).

Theory: The effort distance is the distance moved along the table, whereas the load distance is the *vertical* distance that the object moves. Thus, both the M.A. and V.R. depend on the angle of inclination of the plane.

Applications: Hills, ramps, screws, Egyptian pyramids

Wheel and Axle

11.5.10 Bottle Cap Gearworks

Materials: Soda bottle caps, nails, small piece of wood

Procedure: Find the exact center of each bottle cap and poke a hole through it for the nail. Nail the caps into the wood at even intervals so that they can freely rotate and in turn cause others to rotate. Make different configurations and note the direction of rotation from one gear to another.

Observations: Adjacent gears turn in opposite directions.

Theory: Gears allow for the direction of rotation of a force to be changed. If the gears are of different sizes, then the rates of rotation will also vary.

Hydraulic Press

11.5.11 Syringe Hydraulics

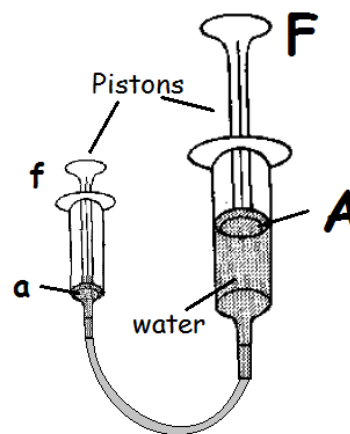

$$\frac{F}{A} = \frac{f}{a}$$

Materials: 2 syringes of different size (5 mL and 20 mL), [Delivery Tube](#), water

Procedure: Fill the larger syringe with water and attach one end of the rubber tubing to its end. Attach the other end of the tubing to the smaller syringe (with its plunger inserted all the way).

Observations: Pushing the plunger of the larger syringe will cause the plunger of the smaller syringe to go out, and vice-versa.

Theory: When the effort piston is forced downwards, the pressure of the liquid, e.g. oil, is transmitted equally in all directions in the whole liquid. Therefore, the pressure at the load piston is the same as at the effort piston. Yet, since the area of the load piston is greater than that of the effort piston, the force at the load piston is greater than that at the effort piston. Thus, a small effort will raise a big load. However, the distance moved by the effort will be larger than that moved by the load.

Applications: Hydraulic systems are used in brakes, pressing bales of cotton, lifting heavy loads (e.g. vehicles in garages), etc.

11.6 Motion in a Straight Line

11.6.1 Object Toss

Procedure: Take any object lying around the classroom and repeatedly toss it vertically into the air while walking around the classroom.

Theory: When the object is first thrown upward, it has an initial velocity. As it continues up, the velocity gets smaller, until reaching zero at the top of its trajectory. It then gains a downward velocity which increases in magnitude. The horizontal motion matches your motion, showing that horizontal velocity is constant.

Measuring Motion

11.6.2 Uniform Motion

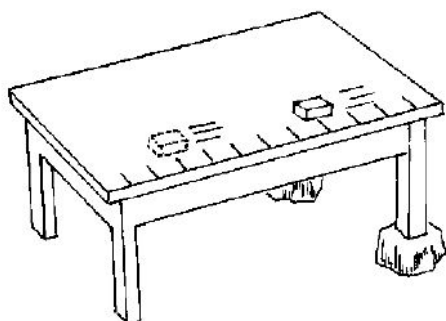

Materials: Chalk, table, matchbox, large rock, ruler

Procedure: Place chalk marks along the long side of a smooth table or plank at an equal distance of 10 cm. Then tilt it so that a matchbox loaded with a stone will just not start to move. Then give the box a little push so that it will move.

Theory: This is a *uniform rectilinear motion*: the velocity is constant, there is no change in velocity, thus the acceleration is zero.

Applications: Where does this motion occur in daily life? - For example, a bus, a train or a boat going at constant speed on a straight line path.

11.6.3 Accelerated Motion

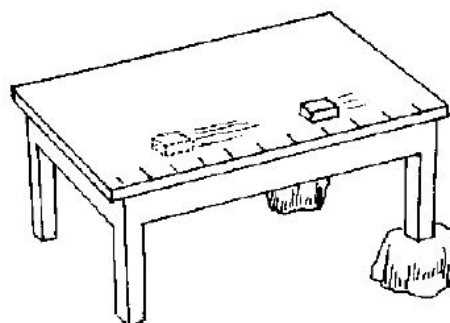

Materials: Chalk, table, matchbox, large rock, ruler

Procedure: Tilt the smooth table or plank more than in the previous experiment.

Theory: This is an *accelerated motion*. Its velocity changes as the box moves down. Its velocity increases. Thus, it is an accelerated rectilinear motion.

Applications: Where do such motions occur in daily life? - For example, a stone falling down; a bus accelerating after the stop; a bus breaking before a stop.

11.6.4 Making the Vehicle

Materials: Matchboxes/block of wood, bottle caps, sand/stones, nails

Procedure: Attach bottle cap wheels to a base made from matchboxes or wood. Fill the base with sand or some other small weight.

11.6.5 Making the Timing Cup



Materials: Plastic cup/tin, dilute ink/food colour, pin, string, stopwatch

Procedure: Pierce a small hole in the bottom of the cup and seal with a pin attached to a string. Fill the cup with ink or food colour. When the pin is pulled out the ink will fall in regular drops. Use a stopwatch to measure the average time between drops.

11.6.6 Ticker Timer

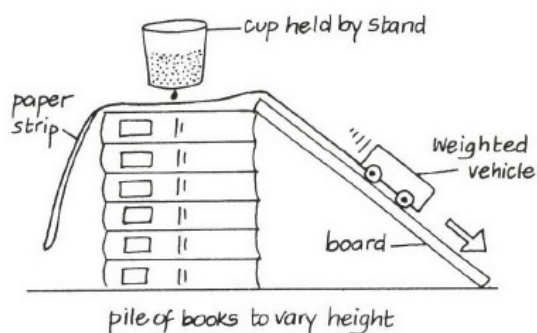

Materials: Long, thin strips of paper, pile of books, board, ruler

Procedure: Pile the books to make slopes of different heights. Attach the ticker tape (paper) to the weighted vehicle. When the vehicle is released, pull out the string in the timer cup. Repeat for a variety of heights and angles of the slope and for different weights in the vehicle.

Questions: Calculate the velocity and acceleration of the vehicle using the distances between dots on the ticker timer and the average time between drops for the timing cup.

Observations: When the car is moving at constant speed, the dots are in regular intervals. When the car is accelerating, the distance between consecutive dots increases.

Theory: Velocity = distance \div time. Acceleration = velocity \div time. By measuring the distance between two dots over a set interval of time, both velocity and acceleration may be calculated.

11.6.7 Determining Acceleration Due to Gravity

NECTA PRACTICAL

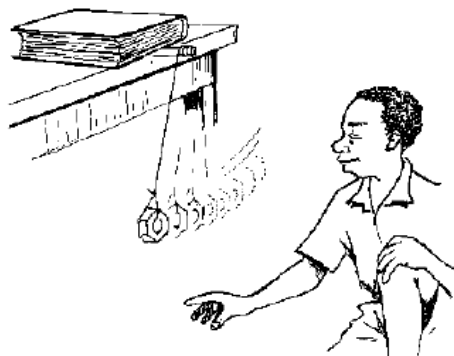

Materials: String, stone, stopwatch, metre rule

Procedure: Tie the string around a stone and hang from a table. Pull the pendulum to one side and release while starting the stopwatch. Record the time taken to complete 10 full oscillations (back and forth). Record the result. Adjust the string length and repeat.

Questions: Calculate the acceleration due to gravity.

Theory: The period T of a pendulum is given by

$$T = 2\pi\sqrt{\frac{l}{g}}, \text{ where } l \text{ is the length of the pendulum and } g \text{ the acceleration due to gravity.}$$

Solving for g , we see that $g = \frac{4\pi^2 l}{T^2}$. Thus, we can calculate the acceleration due to gravity by measuring the string length and *average* period (divide total time by number of periods, in this case 10).

Notes: The mass of the pendulum has no effect on its period.

11.7 Newton's Laws of Motion

Newton's First Law and Inertia 11.7.2 Card Flick

Newton's First Law: *An object at rest will remain at rest and an object in motion will remain in motion at a constant speed in a straight line unless acted upon by an external force.*

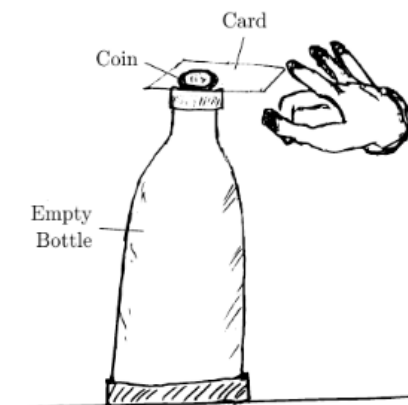

11.7.1 Bucket Swing

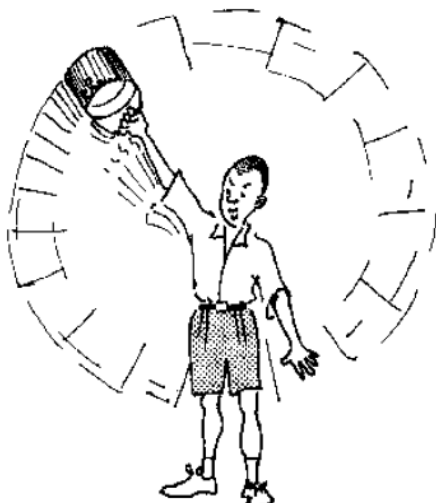

Materials: Bucket, rope, water

Procedure: Fill a bucket about half way with water and attach a rope to the handle. Swing the rope in a vertical circle so that the bucket is facing downwards at the top of its arc.

Hazards: Don't try to stop the bucket at the top of its swing.

Observations: The water remains in the bucket, even when turned upside-down. You can feel the bucket pulling outwards as you spin it.

Theory: The water and bucket are being pulled outwards by a force known as *centripetal force*. This is essentially a result of the inertia of the items, as they want to continue their motion in a straight line path at any given point throughout the swing. You must constantly exert a force on the rope to cause the bucket to change its direction of motion.

Materials: Card, bottle/cup, coin

Procedure: Place the coin on a card so that it rests above the opening of a bottle or cup. Flick the card horizontally.

Observations: The card goes flying off but the coin drops straight down into the bottle.

Theory: The inertia of the heavy coin is large compared to the friction between the card and coin. Thus it remains in place while the lightweight card flies away.

Notes: The trick works best with a heavy coin and by making sure the card is flicked as horizontally as possible.

11.7.3 Bucket Pendulums

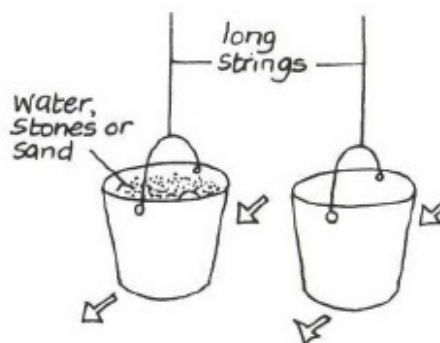

Materials: 2 buckets, sand/water/stones, rope

Procedure: Hang two buckets from a support using rope. Fill one with sand, water or some other weight. Try to push each bucket.

Theory: Inertia must be overcome to start a bucket in motion. The heavier bucket has more inertia and hence requires a greater force to begin swinging.

11.7.4 Standing Passenger

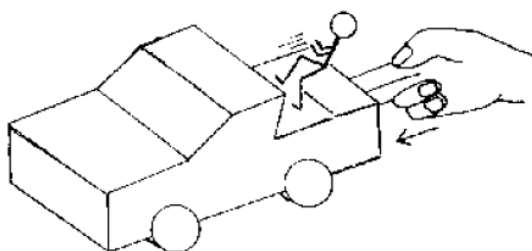

Materials: Toy car, block of wood

Procedure: Make a toy car out of matchboxes and bottle caps so that there is an open space like the bed of a truck. Stand a tall, thin object such as a block of wood or cardboard passenger in the car. Push the car forward suddenly, make it turn a corner and stop it suddenly.

Observations: The passenger falls backward when the car moves forward suddenly; falls to the right when the car turns to the left; and falls forward when the car stops suddenly.

Theory: The passenger's inertia wants to keep the passenger at rest or moving in a straight line at constant speed. When the car accelerates, the passenger falls over.

Applications: Standing on a bus

11.7.5 Spinning Eggs

Materials: 1 fresh egg, 1 boiled egg

Procedure: Place the two eggs on a table. Spin the first egg. Stop it briefly with your hand and then release it. Repeat for the second egg and note any differences you observe.

Questions: Which egg is fresh and which is boiled?

Observations: The fresh egg continues spinning after briefly stopping it, while the boiled egg stops completely.

Theory: The fresh egg contains liquid inside, which continues spinning independent of the egg being stopped, due to its inertia. The boiled egg is solid inside, so it spins as a single unit and stops when the egg is stopped briefly by your hand.

Newton's Second Law and Momentum

Newton's Second Law: *The rate of change of momentum of a body is directly proportional to the applied force and takes place in the direction in which the force acts.*

Force = mass \times acceleration

Momentum = mass \times velocity

11.7.6 Atwood's Machine

Materials: Pulleys, string, Masses, stopwatch, metre rule

Setup: Attach a 1.5 m string to 2 known masses (e.g. 100 g and 90 g). Run the string across the pulley and support the larger mass so that the smaller mass rests on the table. Measure the height h of elevation of the large mass.

Procedure: Release the large mass and use a stopwatch to measure the time taken to reach the table t . Repeat 3 or 4 times and take an average reading for time taken. Repeat for different masses.

Questions: Determine the acceleration of the system using the equation of motion $s = v_0t + \frac{1}{2}at^2$, where $s = h$ and $v_0 = 0$.

Theory: Newton's Second Law tells us that $F = ma$. Here, F is the net force of gravity acting on the system, and is given by $(m_1 - m_2)g$, where g is the gravitational constant. The combined mass of the system is $(m_1 + m_2)$, so the acceleration can be given as $a = \frac{(m_1 - m_2)g}{(m_1 + m_2)}$. Calculate the theoretical value of a using this formula, then compare to the experimental value obtained above.

Notes: Use similar masses to get more accurate results.

11.7.7 Bumping Bottles

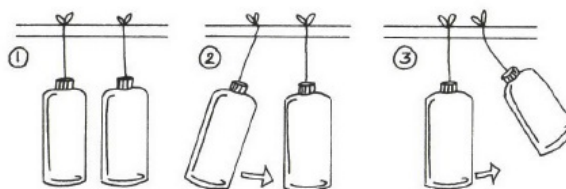

Materials: 2 bottles, string, horizontal support

Procedure: Hang 2 bottles side by side along a horizontal support. Lift one and release it, noting the effect on the other bottle. Then try varying the masses of the bottles by filling them with different amounts of water and try again.

Observations: When the bottles are empty, the first one comes to rest after hitting the second, and the second bottle reaches a height similar to the original release height of the first.

Theory: When the bottles touch, momentum is transferred from one to the other. The relative velocities of the bottles, v_1 and v_2 , depend on their relative masses, m_1 and m_2 , according to $m_1v_1 = m_2v_2$. Momentum is conserved.

11.7.8 Pile of Coins

Materials: Pile of coins and books

Procedure: Try to remove the bottom book without upsetting the pile. Impossible? To remove the bottom coin from a pile, flick another coin at it.

Theory: The momentum of the flicked coin is transferred to the bottom of the pile. The momentum overcomes inertia.

11.7.9 Dropping Fruit

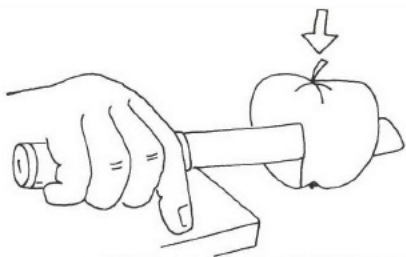

Materials: Knife, fruit

Procedure: Drop a fruit onto a sharp knife from different heights.

Theory: The farther the fall, the greater the momentum and the deeper the cut.

Newton's Third Law

Newton's Third Law: *For every action there is an equal and opposite reaction.*

11.7.10 Balloon Rocket

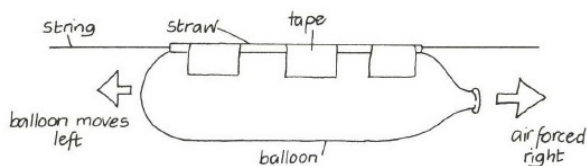

Materials: Balloon, string, straw, tape

Procedure: Run a zip line using string between two tables or chairs. Thread a straw and tape it to the balloon so that it can slide across the line. Blow up the balloon and release it to fly across the string.

Theory: As the air is forced out the opening in the balloon, there is an equal and opposite force applied to the balloon which propels it across the line. This is an application of Newton's Third Law.

11.7.11 Pushing a Canoe

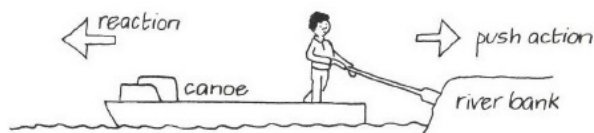

Applications: Jet airliners and canoes employ Newton's Third Law. Hot gases are forced out of an airliner's engines in one direction (action) - this is known as thrust. The plane moves in the opposite direction (reaction). The canoe also moves away from the push action.

11.7.12 Boat Thrust

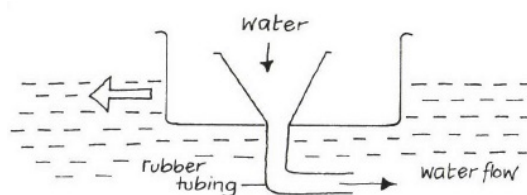

Materials: Plastic container, rubber tubing, funnel

Setup: Make the tug boat as shown.

Observations: As water is poured into the funnel, the boat moves forward.

Theory: Water is forced out the rear tube by gravity (action), which propels the boat forward (reaction).

Applications: Students can compete using different materials to see which travels the fastest.

11.7.13 Pencil Launch

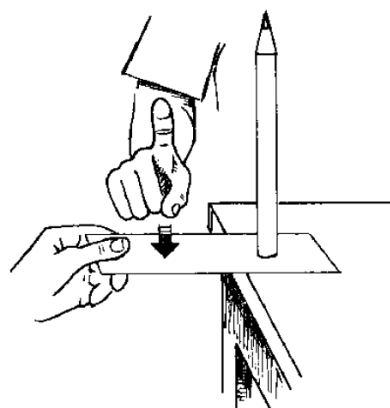

Materials: Pencil, card

Procedure: Stand a pencil upright on a card at the edge of a table. At once hit the card with your finger so that it leaves the table.

Observations: Pushing the card downwards (action) causes the pencil to fly upwards (reaction).

11.7.14 Elastic Boxes

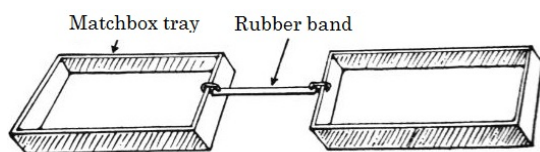

Materials: Matchboxes, rubber band, stones
Procedure: Tie or staple each end of the rubber band to a matchbox tray as shown. Pull the trays apart and then release them both at the same time. Now add stones or small nails in one lid and repeat for different weights.
Observations: When both trays are empty, they pull equally on each other. When stones are added to one, the pull is unequal.
Theory: The stones act with the tray as a single object with more mass, hence it is not pulled as much by the rubber band.

11.7.15 Matchstick Rocket

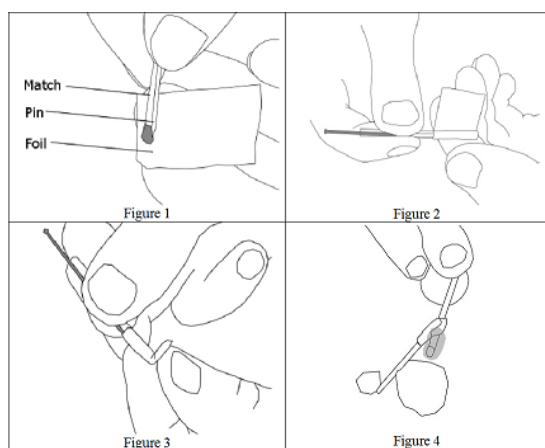

Materials: Matches, aluminum foil, pin/syringe needle
Setup: Rip a small piece of foil about 2 cm × 3 cm. Hold a pin and match together and wrap the foil tightly around the head of the match so that about 1 cm of foil extends beyond the tip. Fold down the extra foil. Remove the pin by sliding it out the bottom, leaving a thin tunnel.
Procedure: Support the match rocket at a 45° angle on a stone. Light another match and hold it under the foil of the rocket.
Hazards: When igniting, keep your face away from the rocket.
Observations: After a few seconds, the rocket is propelled forward.
Theory: The rocket launches when the match head inside the foil ignites due to the heat of the surrounding foil. The gases are expelled backwards through the thin tunnel (action), and the rocket is driven forward (reaction) by an equal and opposite force.

11.7.16 Candle Boat

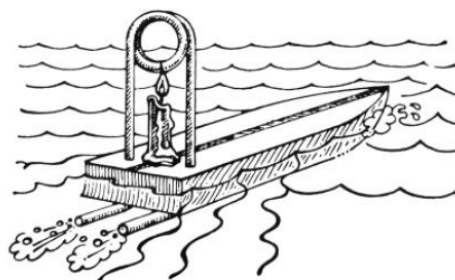

Materials: Candle, wood block, copper tube, basin of water
Setup: Make a small boat using a wood block or plastic/tin container. Insert a loop of copper tubing as shown.
Procedure: Fill the tube with water and place the boat in a large container of water. Set a lit candle under the loop of the tubing.
Theory: As the water is heated inside the loop, it is driven out of one side of the tubing. The backward motion of the water causes the boat to move forward.

11.7.17 Bottle Rocket

Materials: 500 mL bottle, nail, rubber stopper, pin, ball/bicycle pump, tape, pen tube, rigid straight wire (bicycle spoke), water
Setup: Heat a nail and poke a hole in the bottle lid. Cut a round rubber stopper to fit this hole. Pierce the stopper with the needle of the bicycle pump and insert it in the bottle top. Cut a hollow pen tube into two pieces and tape to the side of the bottle in a straight line.
Procedure: Insert the rigid wire into the ground outside. Fill the bottle half way with water and tighten the lid. Mount the pen tube supports on the rigid wire. Insert the bicycle pump needle through the stopper in the lid and pump until the stopper is pushed out completely.
Hazards: Make sure no one is standing in the way of the rocket. Launch in a large open space.
Observations: When the stopper is forced out of the bottle the rocket flies into the air.
Theory: When the stopper leaves the bottle, pressurized air forces water out of the bottom of the bottle at a high speed. This results in a forward reaction force on the rocket.

11.8 Temperature

11.8.1 Principle of a Thermometer

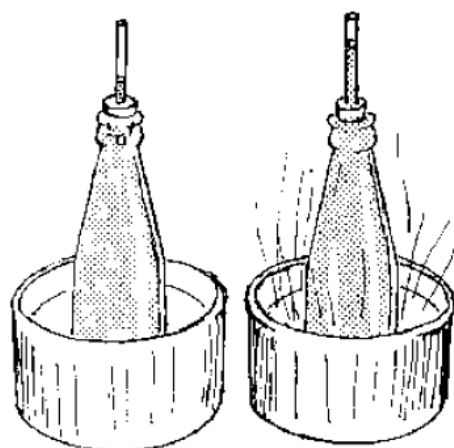

Materials: Bottle, pen tube, stopper/cork/rubber cylinder, food colouring, hot water bath

Procedure: Fill a bottle (about 500 mL) with coloured water up to the rim. Tightly fix a stopper carrying a narrow pen tube into the mouth of the bottle. The liquid level should be just visible above the stopper. Now place the bottle into hot water and heat it for a short time.

Observations: The liquid level rises after heating.

Theory: When liquids are heated, they expand. A thermometer can be made by calibrating the change in volume according to temperature change for a given liquid.

Applications: Clinical thermometers use mercury, while many outdoor thermometers use alcohol. The expansion of alcohol is six times greater than that of mercury. Mercury has a higher boiling point, so it is used to measure higher temperatures.

Questions: Why is water typically not used in thermometers?

11.8.2 Fixed Points of a Thermometer

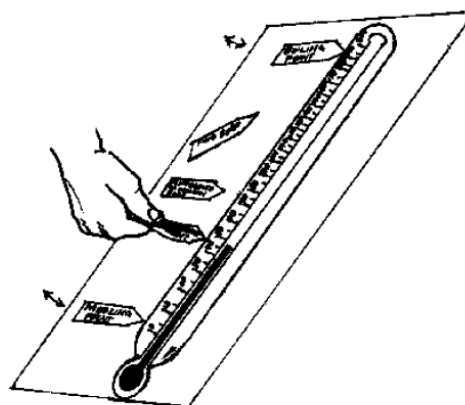

Materials: Cardboard/manila paper, tape, marker pens

Procedure: Draw a large diagram or display chart of a thermometer on manila paper. Use coloured arrows to indicate the characteristic fixed points for water and other substances. Make separate charts for the Fahrenheit, Centigrade and Kelvin scales.

11.9 Sustainable Energy Sources

Water Energy

11.9.1 Water Wheel

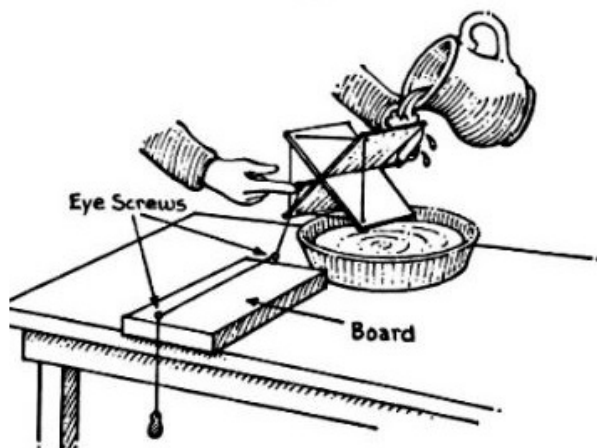
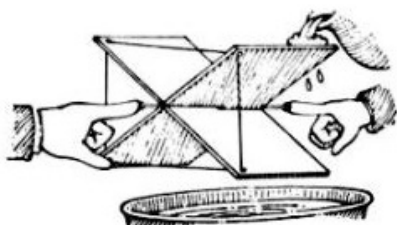
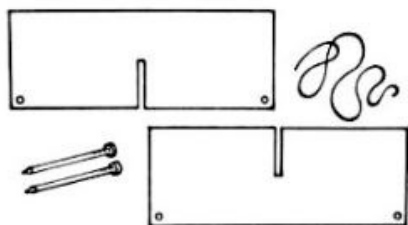

Materials: Stiff cardboard, scissors, nails, string, water, basin

Setup: Construct the water wheel as shown.

Procedure: Tie a small weight (e.g. paperclip, nail) to the string so that it rests on the floor. Pour water over the water wheel to turn it and lift the weight.

Theory: Water stores potential energy in the forms of rivers and waterfalls and when placed in an elevated storage tank. The kinetic energy of falling water can be used to do work on an object and generate electricity.

Applications: [Water Turbine](#) (p. 121).

Solar Energy

11.9.2 Energy from the Sun

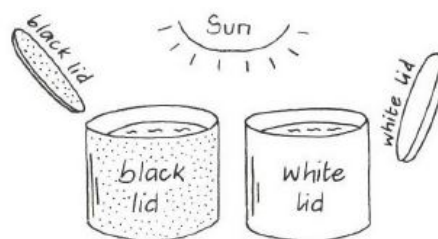

Materials: 2 tins or cans, black paint/shoe polish, aluminum foil

Setup: Paint one tin black and cover the other with aluminum foil.

Procedure: Place both tins out in the sun. Leave for 15 minutes and then feel them.

Observations: The black tin is warmer.

Theory: The sun's energy gets absorbed by objects on earth. Dark surfaces absorb more energy than bright and reflective surfaces.

Wind Energy

11.9.3 Windmills

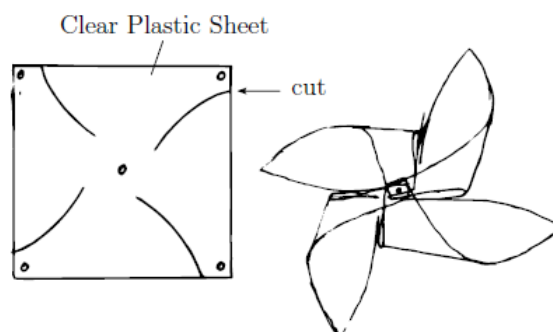

Materials: Paper/thin cardstock, scissors, pen, glue, paper fastener/thumb tack, straw or stick, colored pencils (optional)

Procedure: Copy the illustration onto a sheet of paper or thin cardstock. Cut along the lines and make holes with a pen. Bend the four corners together into the center and glue them in place. Push the fastener through the center into a straw or stick.

Theory: Wind provides kinetic energy which can be harnessed with a device such as a windmill and used to generate electricity if connected to a turbine.

Applications: [Wind Turbine](#) (p. 121).

Physics Activities for Form III

12.1 Friction

Concept of Friction

12.1.1 Useful Friction

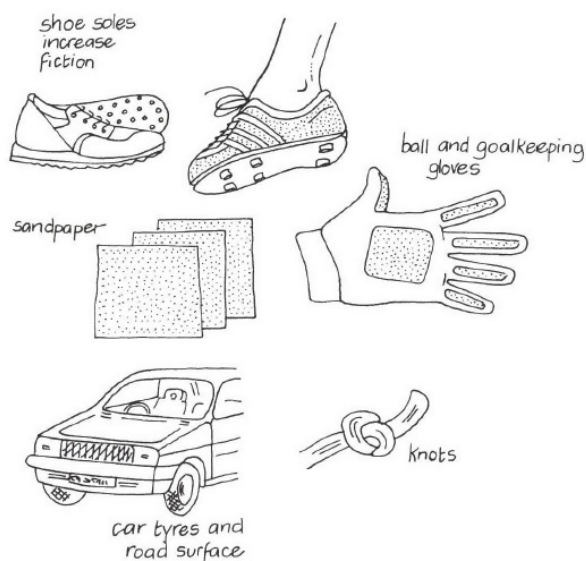

12.1.2 Pencil Roller

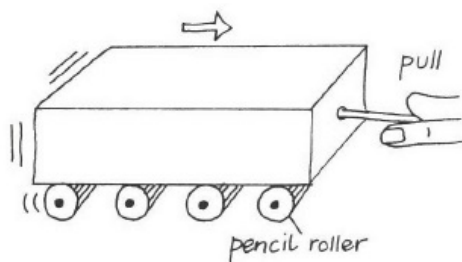

Materials: Pencils, Spring Balance, match-box/block of wood

Procedure: Use a spring balance to pull a match-box or block of wood across a table at constant speed. Then repeat by pulling the object across a row of pencils. Compare the results of the spring balance.

Observations: The spring balance shows a lower force reading when rolled on pencils.

Theory: Rollers reduce friction compared to sliding along a table surface. Because the object is pulled at constant speed, the force on the spring balance is equal to the force of friction acting on the object.

Laws of Friction

12.1.3 Factors Affecting Friction

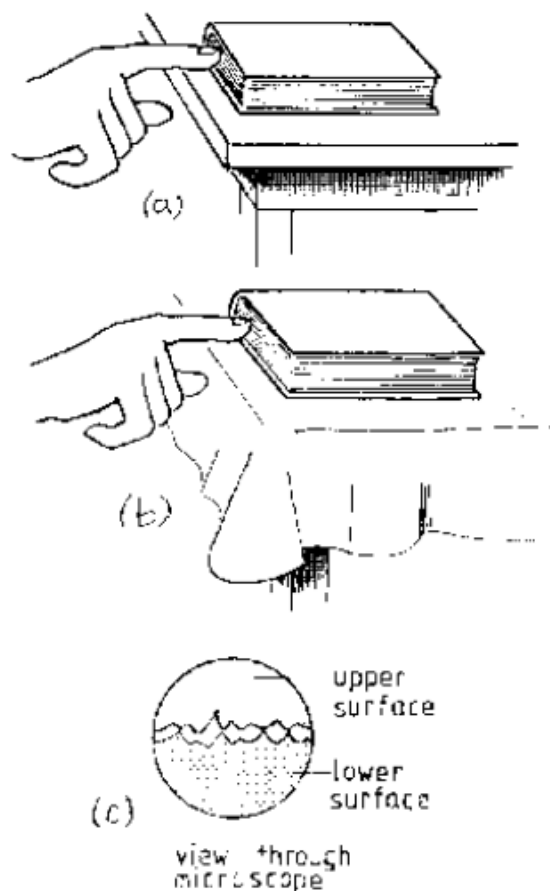

Materials: Books of various sizes, table, cloth

Procedure: Pull a book on a bare surface and then on a piece of cloth. Repeat for a sheet of paper and a thick book of the same page size.

Observations: It is harder to pull the objects on a cloth surface than on a bare table. Heavier objects are more difficult to pull.

Theory: Friction depends on the nature of the two surfaces in contact. It is directly proportional to the normal force (R) between the two surfaces in contact ($F_f = \mu R$). It is independent of the surface area of contact and the relative speed of the objects.

Coefficient of Friction

Applications of Friction

12.1.4 Limiting Friction

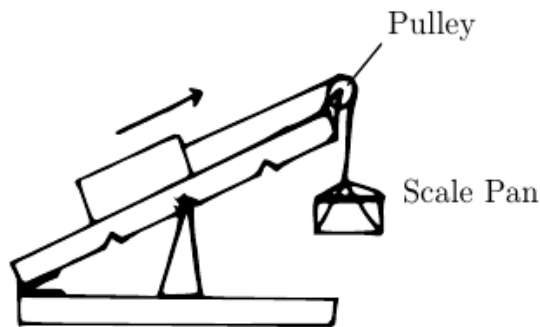

Materials: 2 wooden boards 60 cm × 2 cm, wood block 10 cm × 5 cm × 2 cm, nails, hinge, Masses, string, pulley, protractor, plastic water bottle

Setup: Connect the boards together at one end with a hinge and nails. Attach a pulley to the free end of one board. Prop up this end to create an inclined plane. Cut the bottom 5 cm off of the water bottle to make a scale pan.

Procedure: Record the mass of a wooden block using a spring balance or beam balance and calculate its weight W . Measure the angle of incline θ between the two boards using a protractor. Attach the string to the block on one end, and the scale pan on the other. Add masses to the scale pan until the block just starts to move. Record the mass added and calculate its weight. Repeat for various angles of the incline.

Questions: Calculate the limiting friction and the coefficient of static friction μ_s of the block.

Observations: The mass (and thus weight) required to move the block increases as the angle increases.

Theory: The weight added to the scale pan is equal to the limiting friction F_f of the block. This is the minimum force necessary to move the block. To find μ_s , we use the relation $F_f = \mu_s R$, where R is the normal force. It can be seen through trigonometry that $R = W \cos \theta$ (W is the weight of the block).

$$\text{Thus, } \mu_s = \frac{F_f}{W \cos \theta}$$

12.1.5 Friction Produces Heat

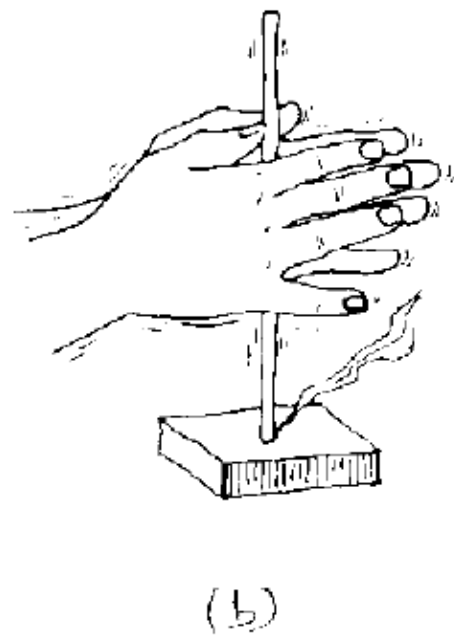
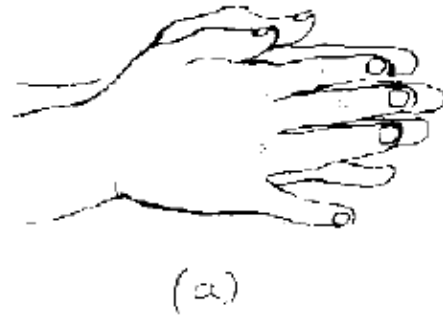

Materials: Stick, piece of wood, matches

Procedure: Rub your hands together and feel the heat produced. Rub a stick into a piece of wood until it begins to smoke and burn. Strike a match against a rough surface.

Theory: Friction produces heat which can start a fire if great enough.

12.1.6 Lubrication

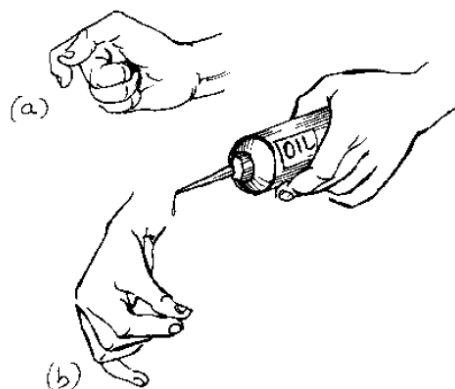

Materials: Cooking oil/margarine

Procedure: Rub your fingers together. Then place a drop of oil on your thumb and repeat rubbing.

Questions: How can friction be reduced in machinery and other moving parts?

Theory: Oil is a common lubricant used to reduce friction between two surfaces.

Applications: Bearings, auto parts, bicycles, gears, etc.

12.1.7 Water as a Lubricant

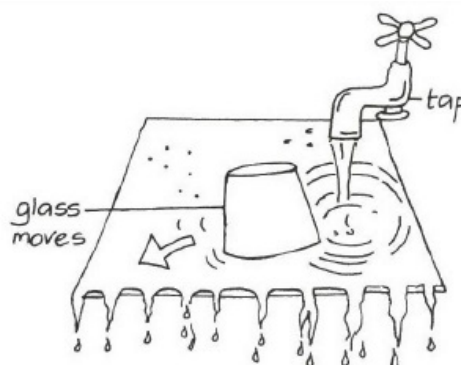

Materials: Sheet of glass, drinking glass, water

Procedure: Cover the sheet of glass with water. Leave a little water in the drinking glass and then invert it.

Observations: The glass floats on a cushion of air and water like a hovercraft.

Theory: The coefficient of friction between glass and water is lower than that of glass and glass. Thus, the water acts as a lubricant and a glass surface is able to move across the surface of water more easily than across another surface of glass.

12.2 Light

Reflection from Curved Surfaces

12.2.1 Radius of Curvature of a Concave Mirror

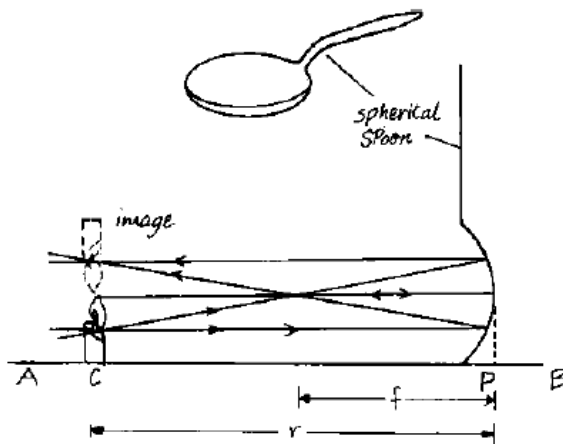

Materials: Spoon, candle/pin, paper

Setup: Draw a line AB on a sheet of paper. Place a concave mirror (spoon) on the paper with its centre vertically above P. Place a lit candle in front of the mirror on line AB as shown.

Procedure: Move the candle along line AB to get a point C where the inverted image of the candle coincides with the object candle.

Questions: Measure the radius of curvature $CP = r$. Compare the values of f and r . Draw ray diagrams to show how the mirror forms images of objects at different positions.

Theory: From the ray diagram, C is the centre of curvature and so $r = 2f$. Ray diagrams show that the *concave mirror* produces a real, inverted and magnified image when the object is beyond F. If the object is closer than F, the image appears behind the mirror (virtual), is erect and magnified.

Applications: Shaving mirror, dentist's mirror, floodlight, torch, car headlight

Notes: The mirror works best as a shaving mirror when the object is closer than F.

12.2.2 Concave and Convex Analogy

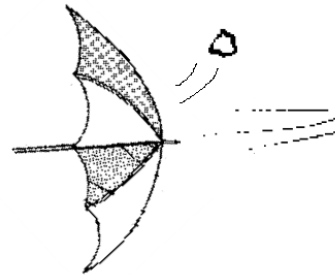

Materials: Umbrella, paper

Procedure: One person holds an umbrella horizontally and another throws a crumpled up piece of paper at it. Try to hit above and below the center. Repeat for the inside of the umbrella.

Observations: The paper balls bounce off the umbrella radially outward for the outer surface, and radially inward off of the inner surface.

Theory: The paper balls represent rays of light which strike the surface of the curved umbrella (mirror) and reflect radially from the focus of the curved surface. The outer surface of the umbrella represents a convex mirror; the inner surface a concave mirror.

Notes: Be sure to throw the paper balls as horizontally as possible.

12.2.3 Images in a Convex Mirror

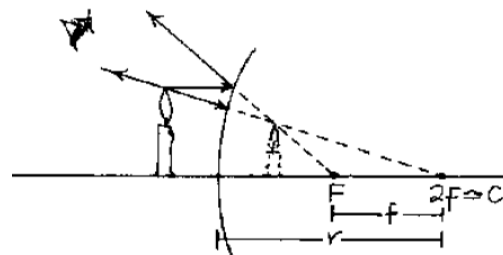

Materials: Spoon, candle/pin, paper

Procedure: Arrange a convex mirror (spoon) and lit candle on a piece of paper as shown. Locate the image formed using a pin or lit candle behind the mirror.

Questions: Mark the position of the object, mirror and image. Measure the object size, object distance and image distance. Draw the ray diagram to show how the convex mirror forms images.

Theory: The image seen is always virtual, erect and reduced in size.

Applications: Rearview mirror in cars, supermarket surveillance

Refraction through Plane Media

12.2.4 Rising Coin

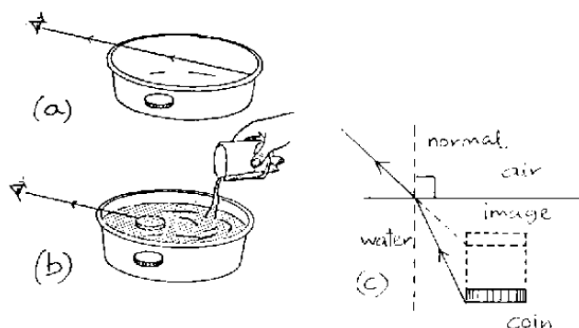

Materials: Coin, dish of water

Procedure: Put a coin in a dish of water. Look across the edge of the lid so the coin is just not visible. Ask someone to gently pour water into the dish, so the eye does not change position.

Questions: What do you see after adding water?

Observations: The coin becomes visible and appears to have risen in the water.

Theory: The ray diagram in (c) shows that we can only see the coin because the light rays coming from it are *refracted* at the water surface away from the normal of the water surface.

12.2.5 Bending a Pencil with Water

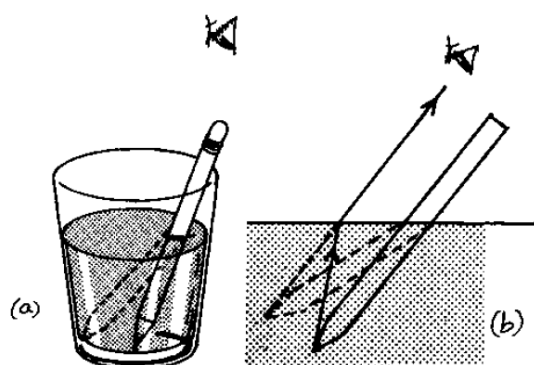

Materials: Glass, pencil, water

Procedure: Pour water in a glass. Place a pencil in the water at a slant (a). Look at the pencil through the surface of the water from the side along its length and note what you see.

Observations: The pencil seems to be bent.

Theory: The ray diagram in (b) explains the observation. Light from the tip of the pencil is refracted at the surface of the water and appears to the eye to be bent.

12.2.6 Candle in Water

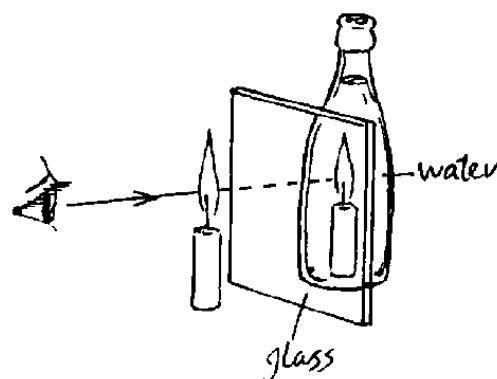

Materials: Glass plane, bottle of water, candle

Procedure: Place a transparent glass plane midway between a lit candle and a bottle full of water. View the bottle through the glass plane from the side of the candle.

Observations: The candle appears to burn in the water in the bottle.

Theory: The light from the candle is refracted by the glass plane, causing it to appear within the bottle.

12.2.7 Refractive Index of Water

NECTA PRACTICAL

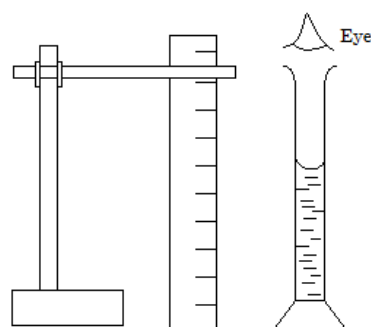

Materials: Measuring Cylinder, Retort Stand, metre rule, pins

Setup: Pour 150 mL of water into the measuring cylinder and drop a pin to the bottom. Look in the measuring cylinder from above. Move another pin up and down outside the cylinder to locate the image position by the no parallax method. Record the depth of the image (H_1) and of the water (H_2). Repeat for 175 mL, 200 mL, 225 mL and 250 mL.

Questions: Plot a graph of H_2 (vertical axis) against H_1 (horizontal axis). Find the slope and give its physical meaning.

Theory: H_1 is the *apparent depth* of the pin, while H_2 is the *actual depth*. Refractive index, η , is found by $\eta = \frac{\text{real depth}}{\text{apparent depth}}$, so the slope of the graph gives the refractive index of water, which should be around 1.33.

12.2.8 Refractive Index of Glass

12.2.9 Total Internal Reflection

NECTA PRACTICAL

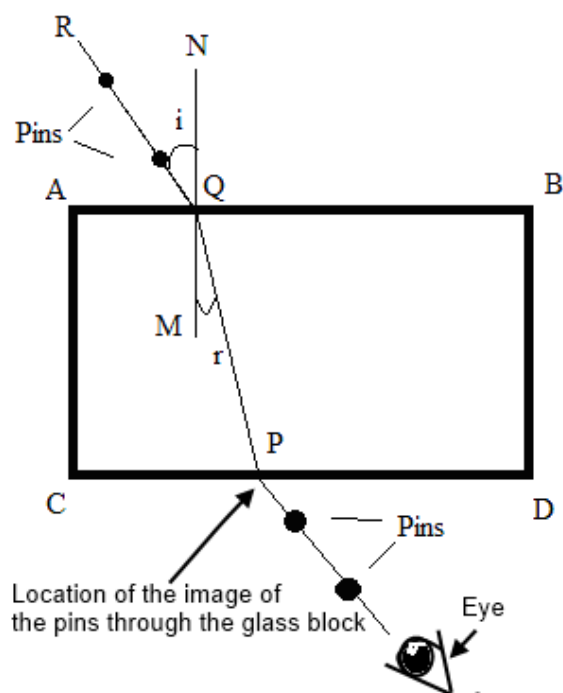

Materials: Glass block, 4 pins, plain paper, ruler, pencil

Procedure: Trace the outline of a glass block ABCD on a piece of paper. Measure an angle of $i = 20^\circ$ and stick 2 pins along this line as shown. Draw the normal to the block surface at Q. Look through the other side of the block (CD) horizontally, and place 2 more pins so that they appear in a straight line with the other pins. Remove the pins and connect with a straight line. Connect points Q and P. Measure the value of r as shown in the figure. Repeat for $i = 30^\circ, 40^\circ, 50^\circ$ and 60° .

Questions: Tabulate results for $i, r, \sin i$ and $\sin r$. Plot a graph of $\sin i$ (vertical) against $\sin r$ (horizontal). Find the slope and give its physical meaning.

Theory: Light is refracted through the glass, so when you look through it, the pins appear to lie on a different straight line. The refractive index, η , can be found by $\eta = \frac{\sin i}{\sin r}$. Thus, the slope of the graph gives the refractive index of glass, which should be around 1.5.

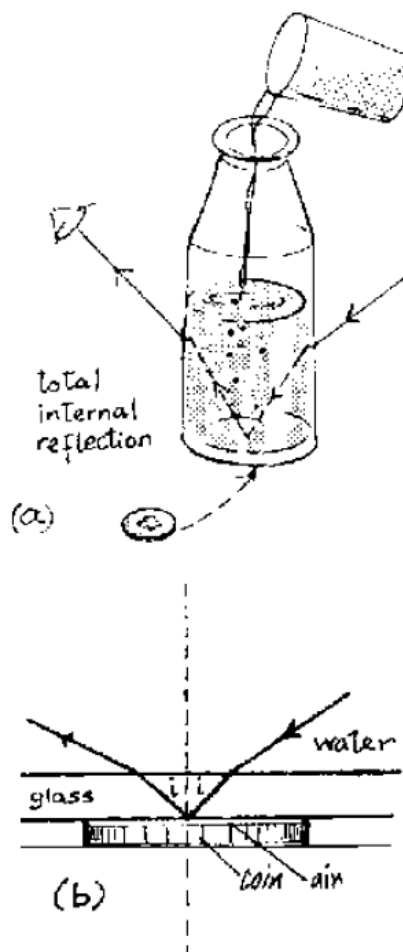

Materials: Bottle, coin, pitcher of water

Procedure: Place a transparent bottle on a coin and look at the coin from above at an angle from the normal. Pour water into the bottle slowly and notice what happens to the image of the coin.

Observations: Initially, the coin can be seen. However, there is a level of water at which the coin disappears from sight.

Theory: At the interface between the glass and air above the coin, *total internal reflection* occurs. This only happens at the boundary between an optically denser medium (e.g. glass) and an optically less dense medium (e.g. air) when the angle of incidence in the denser medium is greater than the *critical angle*. The rays coming from the right side hit the bottom of the glass and are totally reflected (no refraction) before meeting your eye. Thus, these strong totally reflected rays of the bottom of the glass completely cover the weaker rays coming from the coin, and so the coin cannot be seen.

Applications: Prisms in binoculars, periscopes

Refraction by Lenses

12.2.12 Magnification Using a Convex Lens

12.2.10 Plastic and Water Lenses

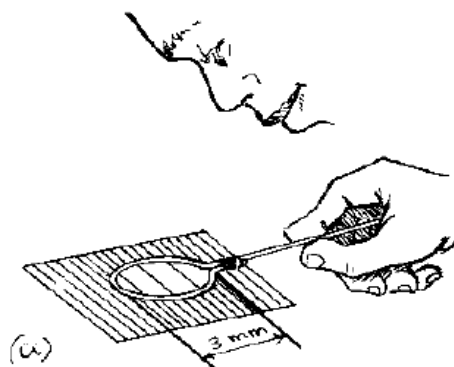
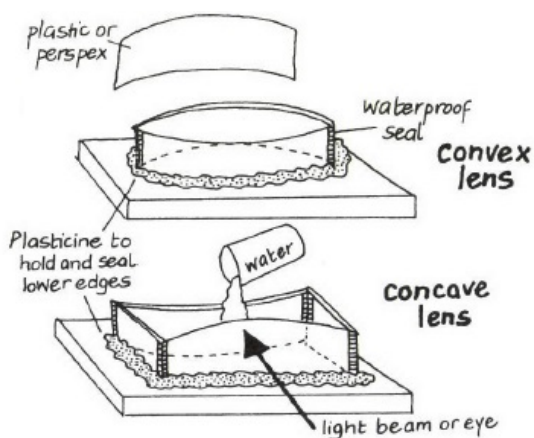

Materials: Sheets of plastic, candle wax, super glue, board, water

Procedure: Bend the plastic sheets into either a convex or concave shape. Keep them in position by bedding them into candle wax on a board. Seal the edges with wax or super glue. Fill the container with water and it acts as a lens.

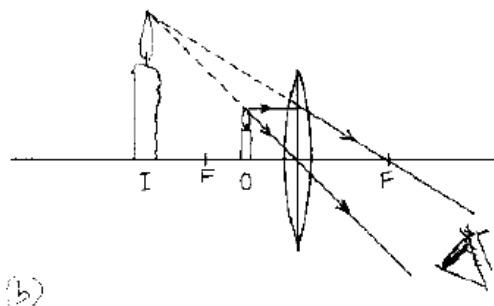

12.2.11 Focusing an Image Through A Convex Lens

Materials: Convex lens (magnifying glass), white paper or screen, tissue paper, pen, point light source (headlamp, desk lamp, etc.), optional retort stand

Procedure: Cut a piece of tissue paper to fit over the light source. Draw a thick arrow on the tissue paper and tape it over the light source. Shine it directly on a white screen or paper about half a metre away (the distance depends on how strong the light is). Move the magnifying glass/convex lens back and forth between the light and screen until the image of the arrow is focused on the screen. Measure the distances from the lens to the screen and lens to the light source.

Questions: Calculate the focal length of the lens.

Theory: The lens equation is given as $\frac{1}{f} = \frac{1}{u} + \frac{1}{v}$, where f is the focal length of the lens, u is the distance from the object to the lens, and v is the distance from the focused image to the lens. By focusing the image, we set u and v and can calculate f .

Applications: Fry bugs with sunlight

Materials: Paper clip, water, water bottle

Procedure: Produce a magnifying glass by looping a paper clip wire around the tip of a pen. Dip the loop in water and hold it above letters in a book.

Observations: The water drop lens acts as a convex lens, magnifying the letter.

Theory: The ray diagram for the convex lens is shown in (b). The image is larger than the object. However, the image is *virtual* because it cannot be obtained on a screen. The object distance u must be less than f .

Applications: Magnifying glass, eye lens of compound microscope, telescopes, etc.

Notes: Alternatively, hold a filled water bottle horizontally over the book and look through.

Dispersion of White Light

12.2.13 Soap Bubbles

Materials: Water, soap, water bottle, straw

Procedure: Make a soap solution by mixing water and soap. Place the soap solution near a source of white light or in open sunlight. Immerse the straw into the soap solution and blow into it to form bubbles.

Observations: Different colours are observed as the sunlight hits the soapy bubbles and undergoes refraction into its component colours.

Theory: Dividing of white light into its colours is called dispersion. This occurs because the light is refracted when passing into the soap and then again when passing back into air.

12.2.15 Mirrors and Water

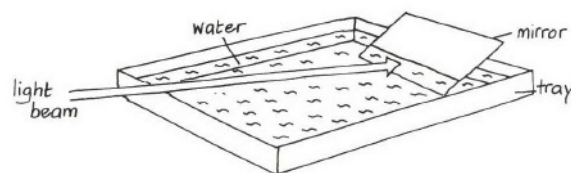

Materials: Plane mirror, tray of water

Procedure: Angle the mirror in the dish of water. Direct a beam of light or sunlight through the water and onto the mirror. Project the light onto a piece of white card or a wall.

Observations: The spectrum of colours can be seen.

Theory: The refraction of the incident colours on the surface of the water and of the reflected rays makes the water act as a kind of prism.

12.2.14 Water Prism

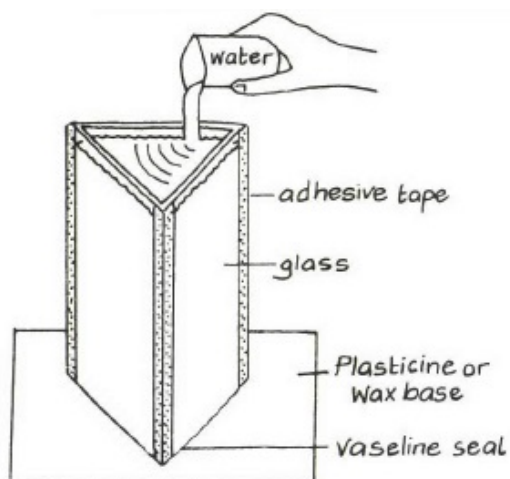

Materials: 3 small sheets of glass, tape, candle wax, Vaseline

Setup: Stick 3 pieces of glass together with tape. Use Vaseline along the joints to make them watertight. Push the prism into a base of Plasticine or candle wax so it is watertight. Fill the prism with water.

Procedure: Shine a beam of light through the prism to view a spectrum of colours.

12.2.16 Water Hose Rainbow



Procedure: In the early morning or late afternoon on a sunny day spray water from a hose pipe against a dark background of trees with your back towards the sun.

Observations: The colours of the rainbow can be seen in the spray from the hose.

Theory: The rainbow is the result of the dispersion of light rays striking water droplets.

Colour

12.2.18 Batik and Tie Dyeing

12.2.17 Colour Wheel

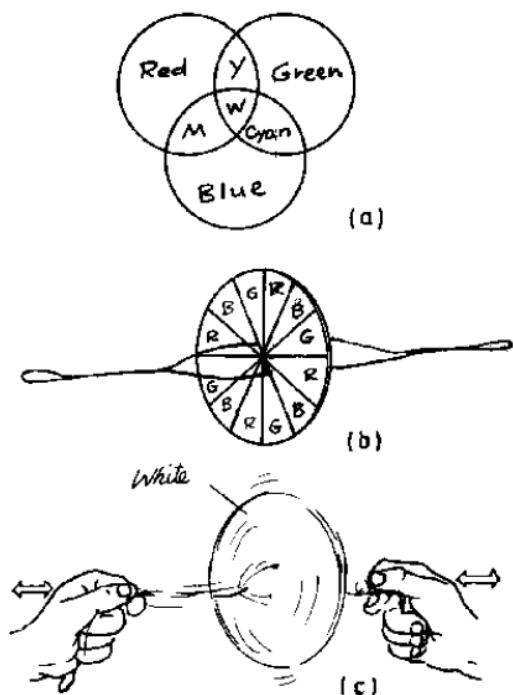

Materials: White card, string, markers or paint of different colours

Setup: Colour 12 equal sectors of a white card disk with red, green and blue colours arranged in that order as shown. Poke two holes around the centre of the disk and tie a string through them.

Procedure: Swing and pull the string ends with both hands so that the disk spins.

Observations: The spinning disk appears white.

Theory: Blue, green and red are *primary colours*, meaning they cannot be produced by combining other colours. When combined together, these colours form white light.

Notes: Try making colour wheels using other combinations of colours to see how they mix together (e.g. red and orange, blue and yellow, red and green, etc.)

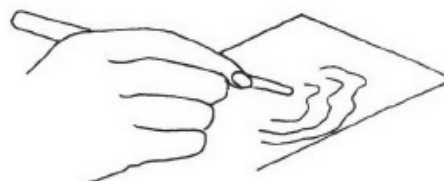

batik dyeing

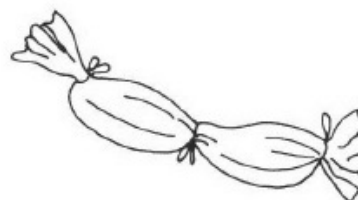

tie dyeing

Materials: Rosella leaves, coloured flowers, fruits, etc., metal container, candle wax, cloth, fine string

Setup: Crush the flowers or fruit and boil in water for 15 minutes or more. Strain the coloured liquid through a cloth into a bucket.

Experiment with different plants to find new colours. For example:

green - spinach or cassava leaves

yellow - onion skins

brown - tea, coffee, iodine

blue - drops of iodine in warm flour solution

Procedure: For batik, draw a design on cloth with molten candle wax. Then place the cloth in the dye. Dye does not affect the waxed areas. After the dye has dried remove the wax by ironing through paper.

In tie dyeing the cloth is pleated and then tied tightly with string. The dye does not penetrate the areas which are tied tightly.

12.3 Optical Instruments

12.3.1 Simple Microscope

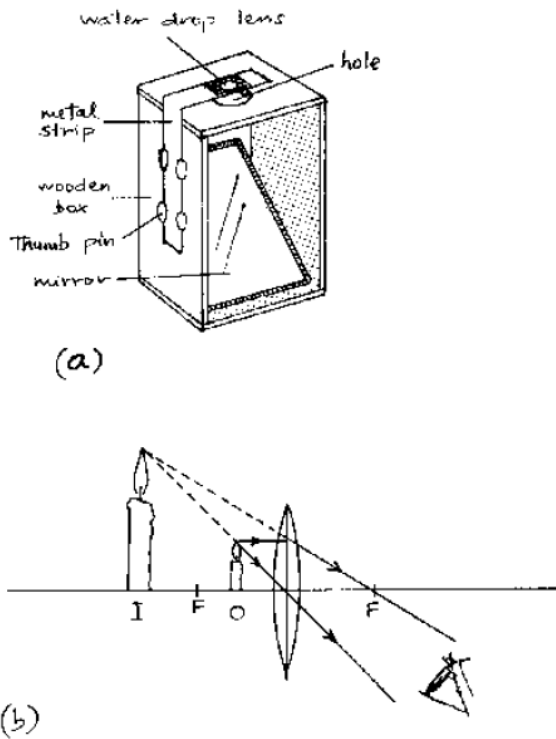

Materials: Mirror, thumb pins, wooden box, metal strip, knife

Setup: Construct the simple microscope according to the figure above.

Procedure: Adjust the mirror so that sun rays are reflected to the hole below the lens. Place a transparent object (e.g. wing of a fly) on the hole and adjust the metal strip so that the water drop lens has less distance from the object than its focal length, as shown in the ray diagram.

Theory: The lens acts as a magnifying glass. When the object distance decreases, the magnification increases

Notes: For more ideas on locally available microscopes, see the section on [Low Tech Microscopy](#) (p. 139).

12.3.2 Human Eye

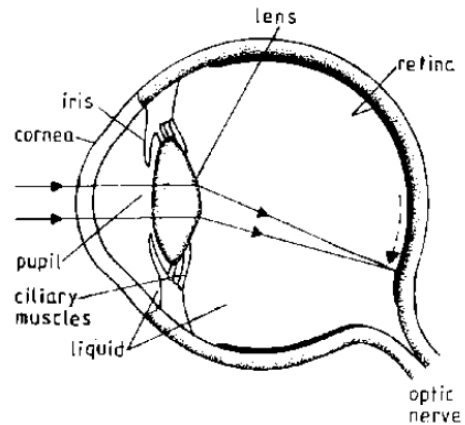

Procedure: Draw a display chart of the above figure on a manila sheet and post in the classroom.

Theory: The eye contains a convex lens which focuses light on a sensitive membrane called the retina. Unlike a camera, the eye lens changes its curvature and hence focal length to focus light from objects at various distances. The focal length varies according to object distance, while the image distance is kept constant and is roughly equal to the diameter of the eye.

12.4 Thermal Expansion

12.4.1 Explaining Expansion



Theory: Expansion can be explained by a simple human model: When a group of students stands still, they are close together and they do not need much space. But if they start to dance or run about, each of them needs more space and the group as a whole takes more space. The particles in a body are like the students, they only move far apart when they are heated and hence need more space.

12.4.3 Expansion of a Coin



Materials: Coin, 2 nails, mounting board/cardboard, candle

Procedure: Place the coin between the nails, then heat the nails.

Observations: The coin cannot be removed after heating the nails.

Theory: Metals expand when heated, thus the nails expand and fit tightly around the coin.

Thermal Expansion of Solids

12.4.2 Ring and Nail

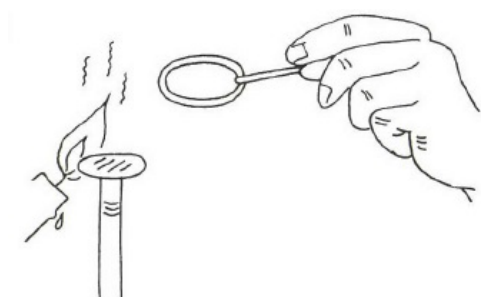

Materials: Nail, wire (10 cm), candle

Procedure: Make a wire loop which is just big enough to pass over the head of the nail. Heat the nail.

Observations: After heating, the loop no longer fits over the head of the nail.

Theory: Heating the nail causes it to expand, and thus the loop can no longer fit over the hot nail head.

12.4.4 Expansion of a Wire

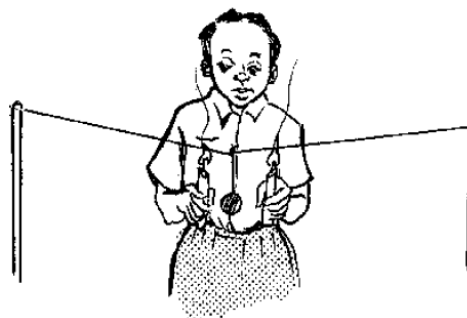

Materials: Copper wire, chairs, small weight, candle

Procedure: Fix a thin copper wire between two chairs and hang a weight in the middle to stretch the wire. Then heat the wire along its length.

Observations: The weight sags further down upon heating the wire.

Theory: The heated wire expands and hence increases its length.

12.4.5 Breaking Glass

Materials: Soda bottle, water, [Heat Source](#)

Procedure: Fill an open glass container about half way with water. Place the bottle over a heat source and wait. If the bottle does not break before the water boils, remove it and place it in a bath of cold water.

Hazards: Be sure the bottle is not covered when heating. If covered, the bottle can explode rather than break evenly.

Observations: The bottle breaks evenly at the level of the water inside.

Theory: The water in the bottle gains more heat than the air above it, so the glass touching the water also gains more heat and thus expands more than the glass above the water. As a result, the glass breaks evenly.

12.4.6 Thermal Switch

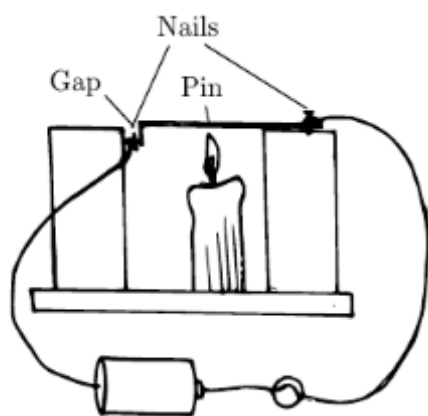

Materials: Piece of wood, 2 thick sticks (5 cm tall), several small nails, pin, connecting wires, 2 dry cells, bulb or galvanometer, candle

Setup: Nail the sticks upright on the wood, a few cm apart. Fix one nail horizontally near the top of one stick. Bend the end of the pin (half cm) at a right angle and place on top of the other stick so that the bent end just touches the horizontal nail. Move the pin back slightly to leave a small gap and fix it in place with another nail. Attach connecting wires to the back end of the pin and the opposite nail, and connect in series with to a bulb/galvanometer and dry cells.

Procedure: Heat the pin until it touches the horizontal nail.

Observations: The bulb lights or the galvanometer shows a deflection.

Theory: Heating the pin causes it to expand and thus close the circuit, allowing current to flow.

12.4.7 Bimetallic Strip

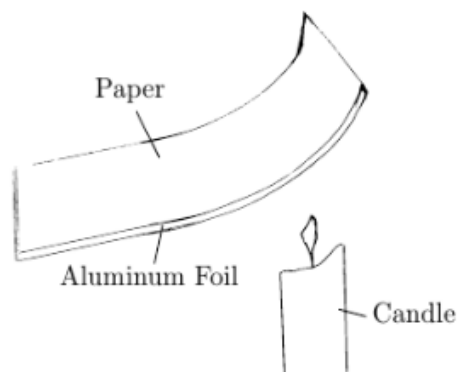

Materials: Strip of paper, aluminum foil, glue, candle

Setup: Cut equal size pieces of aluminum foil and paper (about 3 cm × 10 cm). Glue the two pieces together.

Procedure: Place the bimetallic strip over a flame. Try heating either side.

Observations: The strip bends towards the paper side.

Theory: Aluminum expands more than paper, so the aluminum side becomes longer than the paper side.

12.4.8 Measuring Expansion

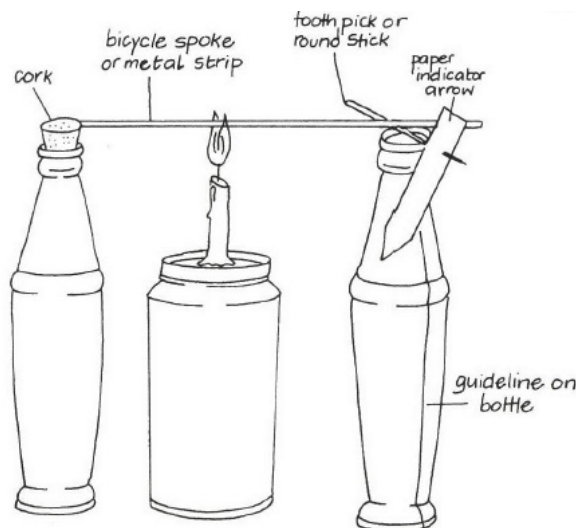

Materials: 2 bottles, cork/rubber stopper, bicycle spoke/thick wire, candle, toothpick, paper

Setup: Push the spoke into the cork so that it is held firmly. Arrange the rest of the equipment as shown.

Procedure: Heat the spoke and observe the paper indicator arrow.

Observations: As the metal is heated it expands and the indicator moves.

12.4.9 Allowing for Expansion

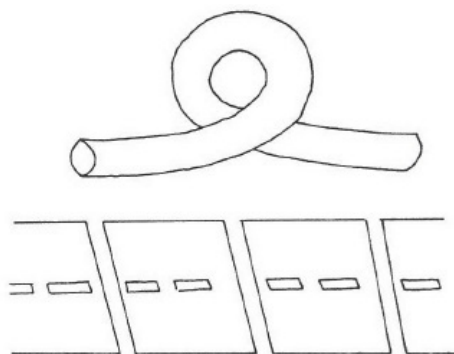

Applications: Steam and oil pipelines in hot areas often have loops to allow for expansion and contraction. Slabs on a concrete road have gaps between them to allow them to expand in the heat. Tar is put into the gaps because it is flexible.

Thermal Expansion of Liquids

12.4.10 Rising Colours

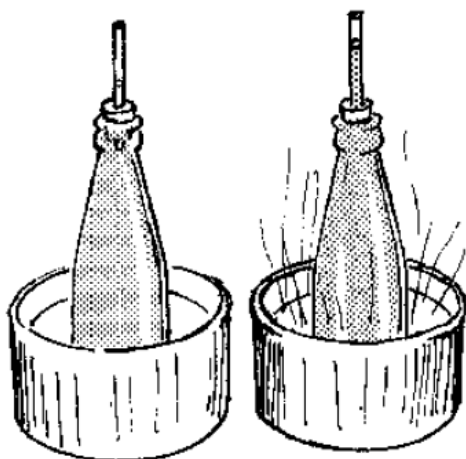

Materials: Bottle, cork/stopper, pen tube, water, food colour, container, [Heat Source](#)

Procedure: Fill a bottle to the rim with coloured water. Tightly fix a cork bearing a transparent hollow pen tube. Place the bottle in hot water.

Theory: The liquid rises in the tube because it is heated by the hot water and expands.

Applications: Mark even intervals on the pen tube to make a simple thermometer.

12.4.11 Jumping Coin



Materials: Bottle, coin, container, [Heat Source](#)

Procedure: Wet the rim of a bottle with water and cover it with a coin. Place the bottle into a hot water bath.

Observations: The coin vibrates, opening and closing the bottle.

Theory: When the air in the bottle expands, it pushes up on the coin, and when the air escapes, the pressure inside drops and the atmospheric pressure pushes down on the coin.

12.4.12 Liquid Thermometers

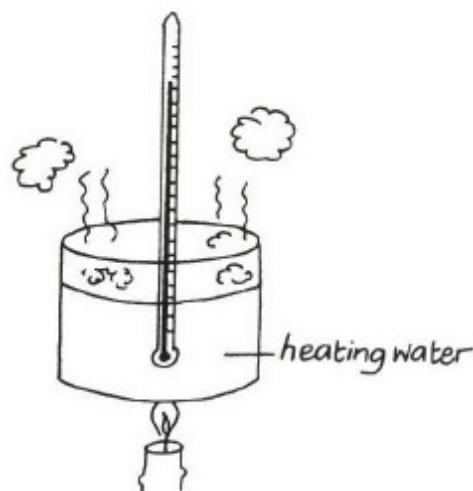

Applications: The mercury or alcohol expands and contracts according to its temperature.

12.4.13 Allowing for Liquid Expansion

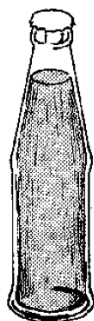

Observations: Observe the liquid level at the top of an unopened soda or beer bottle.

Questions: Why does the bottle contain a small amount of gas trapped above the soda or beer?

Theory: The space is to allow the expansion of soda or beer when the bottle is stored in a warm place.

Thermal Expansion of Gases

Charles' Law

12.4.14 Bottle Crush

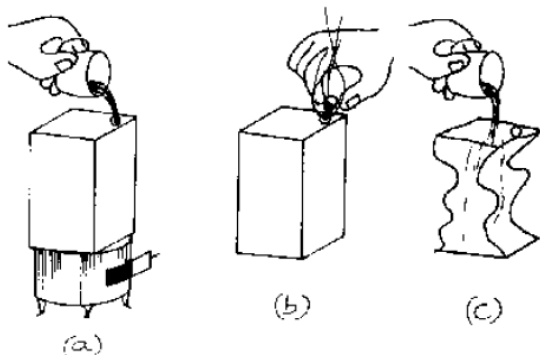

Materials: Plastic water bottle, boiling water, cold water

Procedure: Pour some boiling water into the bottle and cap it immediately. Shake it to make sure all the air inside is heated. Pour out the hot water and cap the bottle. Then pour cold water on the outside of the bottle.

Observations: Upon pouring the cold water, the bottle crushes.

Theory: Boiling water is used initially to increase the temperature of the air in the bottle. It is removed and the bottle is sealed, forcing the pressure to remain constant. As the air inside the bottle cools, it decreases the volume, causing the bottle to be crushed from the inside. $T \propto V$ when P is constant.

Applications: See also .

12.4.15 Egg Suck

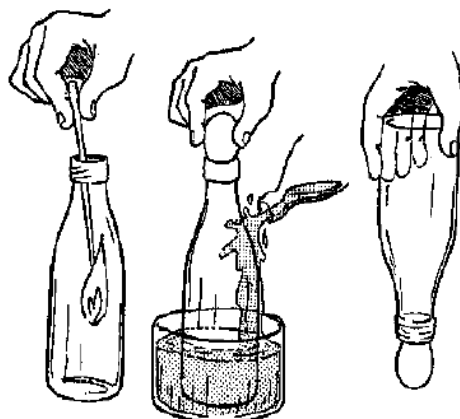

Materials: Bottle, wooden stick, matches, boiled egg, cold water

Setup: Boil and peel an egg.

Procedure: Place an empty bottle into a hot water bath or burn a wooden stick inside of it. After it has warmed up, close the bottle with the egg. Now immerse the bottle in cold water.

Observations: The egg is held by the bottle and may even be sucked into the bottle.

Theory: Cooling the air in the bottle (decrease in temperature) causes it to contract (decrease in volume) and hence lowers the air pressure inside. If the pressure difference with the outside atmospheric pressure is great enough, the egg will be slowly sucked into the bottle.

Notes: Try to use an egg of comparable size to the opening of the bottle.

12.4.16 Spray Balloon

Materials: Can of aerosol spray (e.g. Rungu insect repellent), balloon/plastic bag

Procedure: Place a balloon or plastic bag over the mouth of the spray can and spray into the balloon. Use a funnel if necessary to fill the balloon. Tie the balloon.

Observations: The spray liquefies and is cold inside the balloon. As the liquid warms to room temperature, it changes from a liquid to a gas. Students can hear and feel it boiling. As the gas heats up, the balloon expands.

Theory: The spray begins as a cool liquid when released from the can. As the temperature increases to that of the room, the volume of the trapped gas also increases.

Boyle's Law

12.4.17 Syringe Suck



Materials: Syringe

Procedure: Fill the syringe with air and place a finger at the tip to create a seal. Press the plunger as far as possible.

Observations: It is easy to decrease the volume most of the way but impossible by human means to completely remove all the air inside.

Theory: As you increase the pressure by pressing the plunger, the volume inside the syringe decreases. As the volume decreases, the pressure inside the syringe increases, making it increasingly difficult to continue pressing the plunger.

12.4.18 Balloon Blow

Materials: Bottle, balloon

Procedure: Place a balloon over the mouth of a bottle so that it hangs inside the bottle. Try to blow up the balloon inside the bottle.

Observations: It is impossible for a normal person to fill the balloon.

Theory: In order to fill the balloon, the volume of air inside the bottle must decrease. For this to happen, Boyle's Law states that the pressure must increase. A normal human's lungs cannot blow at a high enough pressure to fill the balloon inside the bottle.

12.4.19 Balloon Suck

Materials: Balloon, plastic bottle, straw, super glue

Setup: Put a straw through the wall of a plastic bottle and seal with super glue.

Procedure: Place a balloon over the mouth of the bottle so that it hangs inside the bottle. Use the straw to suck air out of the bottle.

Observations: As the air is sucked through the straw, the balloon fills with air.

Theory: Sucking air out of the bottle decreases its volume. Atmospheric pressure compensates by pushing the balloon into the bottle, which fills up with air.

12.5 Transfer of Thermal Energy

Conduction is the transfer of heat *through a material* from a region of higher temperature to a region of lower temperature.

Convection is the transfer of heat *in fluids* due to the movement of material particles of the medium.

Radiation is the transfer of heat from one place to another without the use of any material medium.

12.5.1 Football Model of Thermal Energy

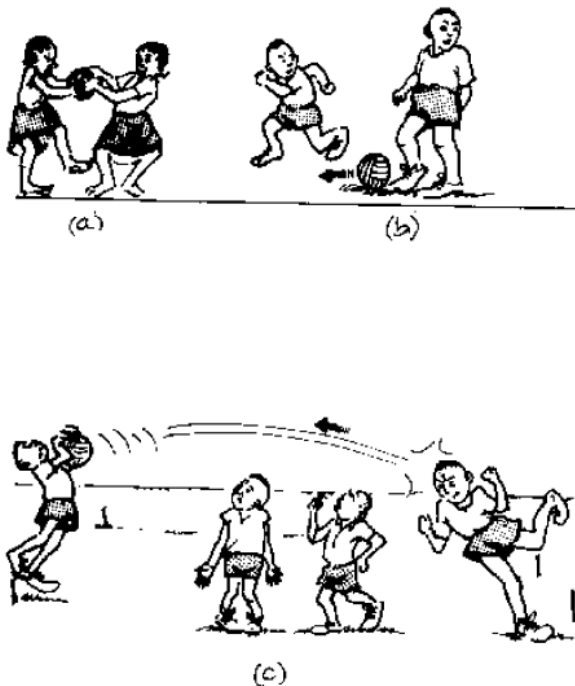

Conduction is likened to a football being passed from one player to another, just as heat passes from one molecule to another (a).

Convection is likened to a football being taken by one player from one point of the field to another, just as heat in a fluid is transported by a particle from one point to another (b).

Radiation is likened to a football being kicked by one player from one point to another without the use of intervening players, just as heat is transmitted from a hot object to another without any medium (c).

12.5.2 Heat Transfer in a Candle

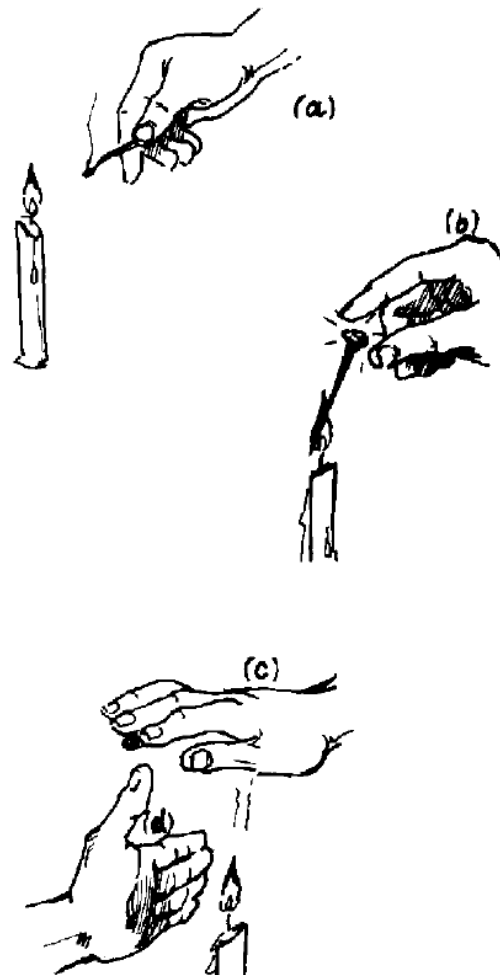

Materials: Candle, nail

Procedure: Light a candle to demonstrate three forms of heat transfer by simple hand movement (a).

Conduction: Stick one end of a nail into the flame (b).

Convection: Place your hand above the flame (c).

Radiation: Place your hand at the side of the flame (d).

Notes: To see the amount of heat transferred for each case, hold a new matchstick in each arrangement and see how long it takes to ignite the match.

Conduction

12.5.3 Good and Bad Conductors of Heat

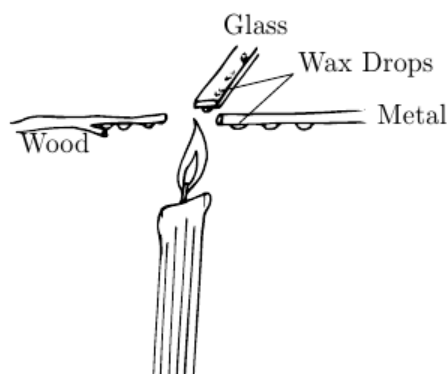

Materials: Iron nail, piece of glass, wooden stick, candle, matches

Procedure: Use a lit candle to drip wax at even intervals along the glass, iron and wood (about 1 cm apart). Set the items on the edge of a chair so that one end of each sticks out above the candle (they should not be touching).

Observations: The wax on the iron nail melts quickly, near the candle first, then moving back along the nail. The wax on the glass melts very slowly while the wax on the stick does not melt at all.

Theory: Heat moves quickly through metal and slowly through wood and glass. Thus metal is a good conductor of heat and glass and wood are poor conductors of heat.

Applications: Cooking pots are made of metal to efficiently transfer heat to the food. *Insulators* are used to prevent heat loss (e.g. in clothes).

12.5.4 Rate of Conduction

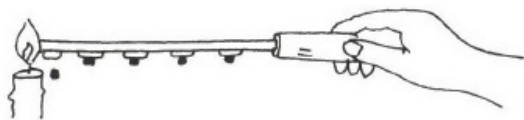

Materials: Candle, metal rod, small stones or seeds, cloth/paper

Procedure: Use drops of candle wax to stick small stones onto the metal rod at regular intervals. Use a cloth as a handle to hold the end of the rod over the flame.

Observations: The stones drop off one-by-one along the rod as that part of the rod gets hot.

Theory: The rod conducts heat from the flame, beginning near the flame and then moving back.

12.5.5 Coin Burn

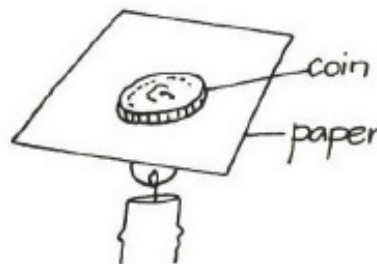

Materials: Coin, paper, candle

Procedure: Place a coin on a piece of paper and hold above a candle so that the coin is directly above the flame.

Observations: The paper does not burn! Why?

Theory: Metal is a better conductor of heat than paper, so the coin conducts heat away from the candle before the paper burns.

12.5.6 Paper Pan

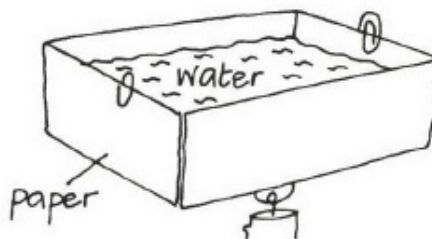

Materials: Paper, paper clips, tape, water, candle

Procedure: Construct a water pan out of paper using paper clips and tape. Fill the pan with water and place over a candle.

Theory: The paper does not burn as the heat is conducted by the water and the paper never rises above 100°C.

12.5.7 Fireproof Material



Materials: Coin, cloth, candle

Theory: A coin conducts heat away before the cloth can burn.

Hazards: Do not use synthetic materials as many melt at quite low temperatures.

12.5.8 Candle Snuffer

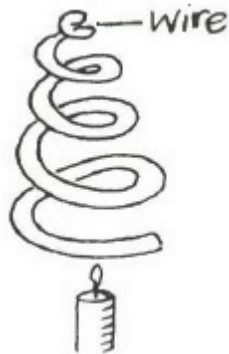

Materials: Thick copper wire (about 40 cm), candle

Procedure: Bend the wire into a spiral coil, leaving enough length for a handle. Light a candle and then put out the flame with the snuffer.

Theory: Copper is a good conductor of heat and thus conducts all of the heat away from the flame.

12.5.10 Convection Currents



Materials: Clear container/bottle, water, sawdust, candle

Procedure: Fill a container with water and a small amount of sawdust. Heat the container and observe the sawdust.

Observations: The convection currents are visible in the water.

Theory: The warm water rises and the cooler water sinks down to the bottom as seen by the movement of the sawdust. As the water on top cools, it sinks again to replace the new warm water rising, continuing the cycle.

Applications: Wind, breeze currents

Convection

12.5.9 Convection Detectors

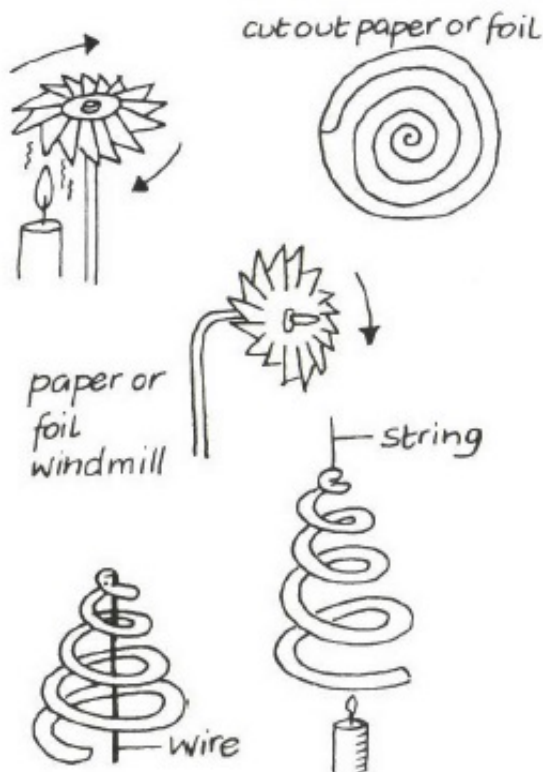

Procedure: Make the convection detectors shown. If held above a candle they will turn around.

12.5.11 Breeze as a Convection Current

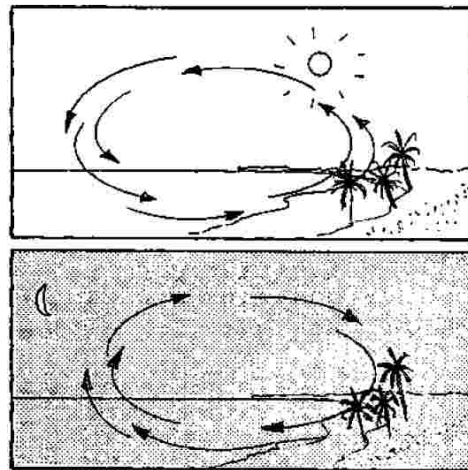

Observations: At the coast and on lake shores, a gentle air stream or breeze is always blowing. The direction of the breeze during the day is different from that at night.

Theory: During daytime, the land warms up faster than the sea. The warm air rises over the land and cooler air from the sea flows to the land. This creates a breeze from sea to land.

During night, the water stays warmer than the land, air over the water rises, colder air from the land flows to the sea. This creates a breeze from land to sea.

12.5.12 Ventilation System

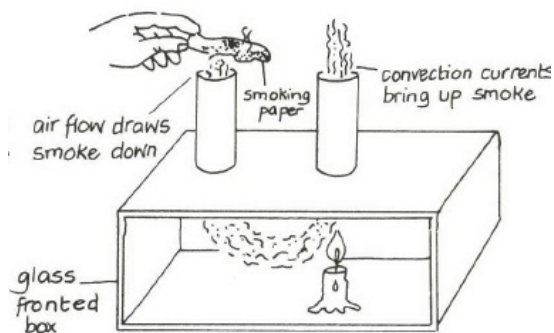

Materials: Glass- or plastic-fronted box, 2 cardboard tubes, candle, smoking paper

Setup: Make 2 holes in the top of the box and push in the cardboard tubes. Place a candle under one of the tubes.

Procedure: Light the candle and hold a smoking cloth or paper above the other tube.

Observations: Smoke is drawn into the first tube and flows out the other.

Theory: Convection currents can be seen by the movement of the smoke. The air heated by the candle rises, allowing for cooler smoky air to flow downward through the first tube. As this air is heated, it then moves upward out of the second tube.

Applications: Ventilating a room, drawing in cool air to a container

12.5.13 Hot Air Balloon

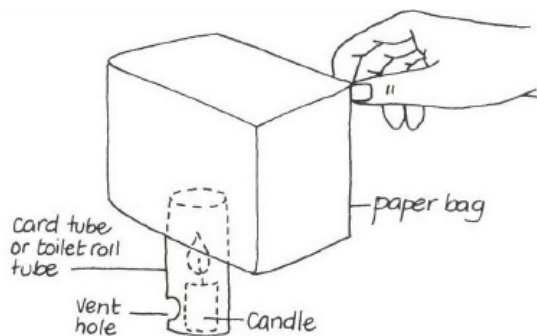

Materials: Lightweight paper bag, candle, cardboard tube

Setup: Cut a small vent hold at the bottom of a toilet paper tube and place a candle inside the tube.

Procedure: Light the candle and hold the bag over it.

Observations: The bag rises as the air inside heats up.

Theory: Warm air is lighter than cool air, so it rises upward. If the bag is light enough, it will be lifted by the air current.

Applications: Have students design their own hot air balloons and test which flies highest.

Radiation

12.5.14 Good and Bad Radiators

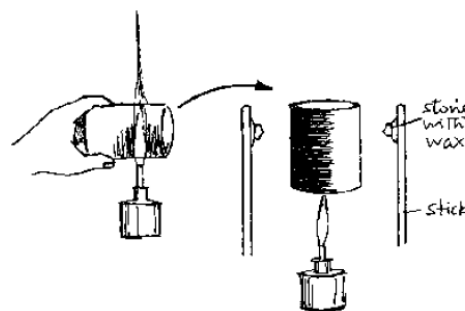

Materials: Shiny can, black paint/shoe polish, 2 wooden sticks, candle, 2 small stones

Setup: Paint one half of the outside of an open can or cover with soot by holding over a candle. Leave the other half shiny.

Procedure: Place a wooden stick near each side of the can. Stick a small stone with candle wax on each stick. Heat the bottom of the can.

Observations: The candle wax opposite the blackened surface begins to melt faster than the wax opposite the shiny surface.

Theory: A black surface is a better radiator than a shiny surface.

12.5.15 Good and Bad Heat Absorbers

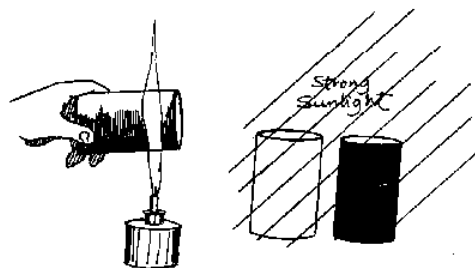

Materials: 2 identical cans, black paint/shoe polish, candle

Setup: Paint the outside of one can black or cover with soot by holding it over a candle.

Procedure: Place both cans in the sun or at equal distances from a fire for about a half hour. Then feel each can.

Observations: The blackened can is hotter than the shiny can.

Theory: A black surface absorbs heat more quickly than a shiny surface.

Applications: It is wise for people in hot areas to wear bright clothes and paint their houses white so that they absorb less heat.

Questions: What colour should a petrol tank be painted? Why?

12.6 Measurement of Thermal Energy

Specific Heat Capacity

12.6.1 Specific Heat Capacity of Liquids

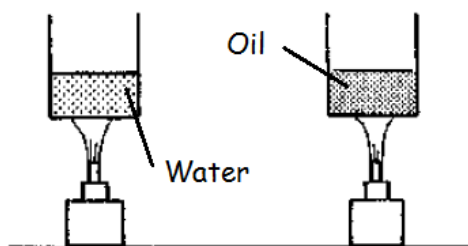

Materials: Heat Source, 2 containers, water, oil
Procedure: Heat equal masses of different liquids (e.g. water and oil) in two identical containers for the same length of time.

Hazards: Take great care not to overheat the oil, as it can catch fire. Do not touch if you have heated it for a long time.

Questions: What difference in temperature can you feel with your finger?

Theory: The temperature of the oil is higher because it needs less energy to raise the temperature of one gram of oil by 1°C than that of water. Thus, using the same amount of heat and mass, the temperature of the oil must be higher.

12.6.2 Mass and Thermal Energy

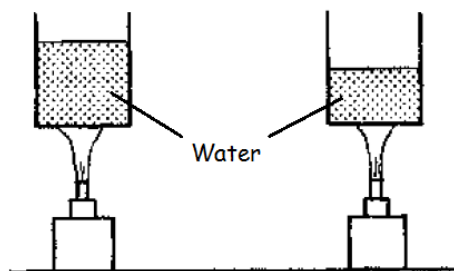

Materials: Heat Source, 2 containers, water
Procedure: Heat different quantities of water in two identical containers (e.g. tin cans) for the same length of time. Dip your finger into the two containers of water.

Questions: What difference in temperature can you feel?

Theory: The temperature of the smaller quantity of water is higher, because it received more thermal energy per gram of its mass than the larger quantity. So for the same heat input the temperature rise of the smaller quantity of water will be greater.

12.6.3 The Calorimeter

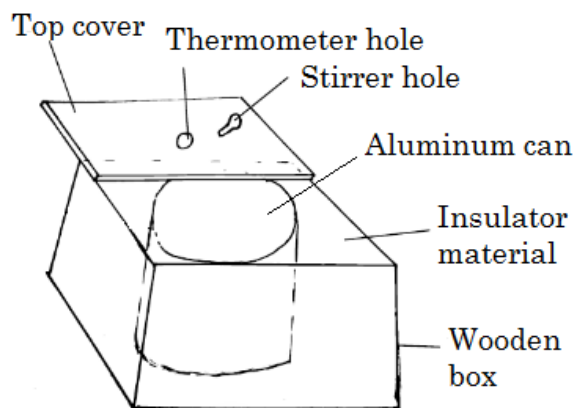

Materials: Wooden box (10 cm \times 10 cm \times 12 cm), ceiling board/piece of wood, aluminum can, aluminum wire, pieces of blanket/sweater, thermometer

Setup: Prepare a wooden box with a cover from wood or ceiling material. Use aluminum wire to make a stirrer with a rubber holder.

Procedure: Place the piece of blanket in the box as an insulator, then the aluminum can with stirrer. Place the top cover on the box, followed by stirrer holder and thermometer in the middle hole.

Theory: To measure specific heat capacity, a liquid of known mass and temperature is added to the container (e.g. water) and a solid or liquid of known mass and temperature (and unknown specific heat capacity) is added to the liquid.

Applications: The specific heat capacity, c of the object can be found by using the relationship $(mc\Delta T)_{object} = (mc\Delta T)_{al} + (mc\Delta T)_w$, where c_{al} and c_w are known for aluminum and water and all masses and temperatures are measured.

Notes: The can and stirrer must be of the same material.

12.6.4 Determining Specific Heat Capacity of a Liquid

Materials: Thermometer, water, any liquid, [Measuring Cylinder](#), small pot, glass jar, [Heat Source](#)

Procedure: Measure a known volume of the liquid into a glass container. Heat the water in the pot over a stove until it is significantly warmer than the other liquid. Measure the volume of the water in the measuring cylinder. Before mixing the liquids, measure each temperature and record it. Now pour the hot water into the other liquid and wait for the temperature of the mixture to equalize. When the temperature levels off, measure and record it.

Questions: Determine the specific heat capacity of the liquid.

Theory: Since the liquid and water are being mixed, the same amount of heat energy H used to raise the liquids temperature is lost by the water to cool it down. Thus $H_w = H_l$, or $(mc\Delta T)_w = (mc\Delta T)_l$. The masses of the substances are known from their densities or measured, and the changes in temperature are measured with the thermometer. The specific heat capacity of water is 4200 J/kg K, so the specific heat capacity of the liquid can be found.

12.6.5 Application of Specific Heat Capacity



Procedure: Use your hand to find out how fast a water puddle and a heap of sand warm up during the day and cool during the night.

Observations: The sand heats up faster during the day and cools down faster at night.

Theory: Sand has a lower specific heat capacity than water ($c_{water} = 4200$ J/kg K, $c_{sand} = 800$ J/kg K), and so less heat energy is required to change its temperature.

Change of State

There are three states of matter, *solid*, *liquid* and *gas*. Matter can be converted from one state to another:

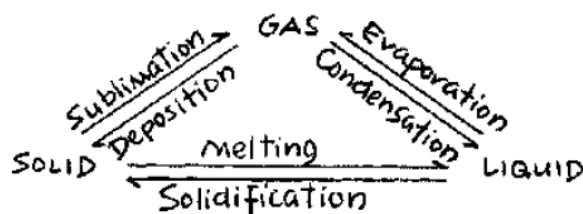

12.6.6 Condensation

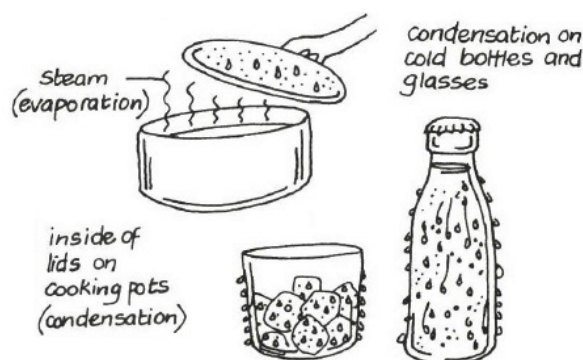

Condensation occurs when a gas (e.g. water vapour) cools down and becomes a liquid.

12.6.7 Bottle Condensation

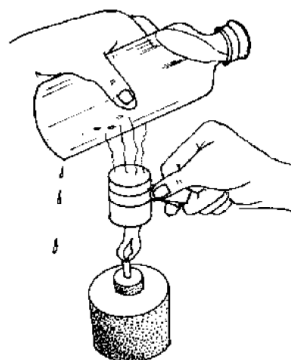

Materials: Tin can, glass bottle, water, [Heat Source](#)

Procedure: Pour a small amount of water into a tin can and heat it until it boils. Fill a bottle with cool water and hold it above the tin can.

Observations: Water drops form on the outside of the cool bottle when it is touched by the steam of the boiling water.

Theory: Water particles escape from the boiling water as vapour and condense on the lower surface of the bottle to form water droplets. Hence water is made up of small particles.

Melting Point

12.6.8 Determining Melting Point

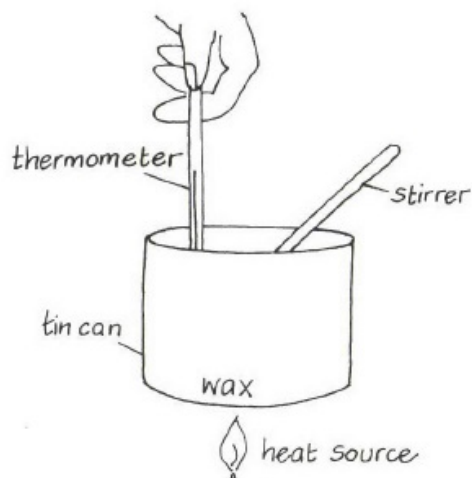

Materials: Tin can, thermometer, stirrer, Heat Source, candle wax

Procedure: Gently melt the wax, stirring continuously to make sure the thermometer does not rest on the bottom of the tin. Record the temperature at which all of the wax has melted.

Observations: You should notice that the temperature remains constant until all the wax has melted, then begins to rise.

Theory: The point at which the temperature changes is the melting point.

Applications: Collect several temperatures over time and make a temperature-time graph for wax.

Boiling Point

12.6.9 Impurities and Boiling Point

Materials: Tin can, salt, Heat Source, thermometer

Procedure: Add water and a small amount of salt to a container and heat over a stove. Measure the temperature at which the water boils.

Observations: The water boils at a temperature slightly higher than 100°C when salt is added.

Theory: Impurities such as salt increase the boiling point of water.

Applications: Adding salt causes water to take a longer time to begin boiling, but when it does boil it is at a higher temperature and thus can cook food faster.

12.6.10 Boiling Water at Room Temperature

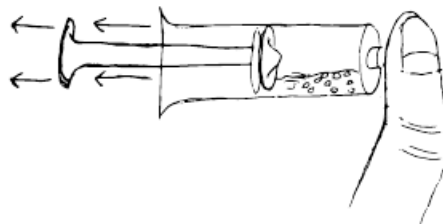

Materials: Syringe (10 mL or 20 mL), water

Procedure: Fill the syringe with a small amount of water. Place your thumb over the opening and pull the plunger out as far as you can.

Observations: When the plunger is pulled back the water begins to bubble, meaning that it is boiling.

Theory: The pressure inside the syringe decreases, and the boiling point of water is decreasing with the pressure. When the boiling point is reduced to room temperature, the water begins to boil.

Notes: The activity will not work if you use too much water.

12.6.11 Pressure Cooker

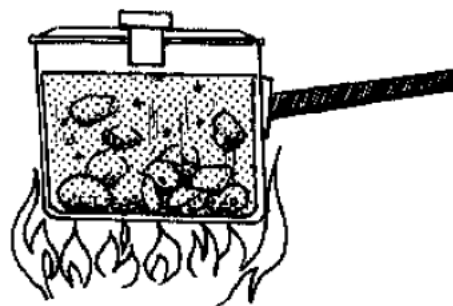

Theory: Under the high pressure in such a pot the water boils at a higher temperature of about 120°C . At this temperature food like beans need only about one hour (instead of 3 in a normal pot) to cook and become soft. Therefore the pressure cooker uses less fuel to cook.

Applications: At high altitudes air pressure decreases, and thus water boils at a lower temperature. So food would need a very long time to be cooked (e.g. at the top of Mount Kilimanjaro). To cook food faster we need to use a pressure cooker to increase the temperature inside.

Hazards: Do not try to make a homemade pressure cooker as it can easily explode.

Evaporation

12.6.12 Evaporation and Cooling



Materials: Petrol/spirit (e.g. Konyagi)

Procedure: Pour some petrol or spirit on the back of your hand.

Theory: The back of the hand feels cold, because evaporation of the spirit needs energy which it absorbs from the skin.

Applications: When you go swimming and come out of the water, you feel cold because evaporation of water from your body absorbs heat from your skin. This is also why the body produces sweat in order to cool down.

12.6.13 Cooling Water



Applications: In many houses water is kept in fired clay pots (*chungu*). They have very tiny pores through which minute amounts of water ooze out.

Theory: Some water passes through the tiny pores and evaporates. The energy needed for the evaporation is taken from the pot and water and hence the water cools down.

12.6.14 Latent Heat of Vaporisation

Materials: Heat Source, water, small pot, thermometer

Procedure: Fill the pot half-way with water and heat with a thermometer inside. Record the temperature every 10 seconds after the water begins to boil.

Questions: Plot a graph of temperature (vertical axis) against time (horizontal axis).

Observations: The temperature increases steadily as the water is heated, then upon boiling remains constant while the water vapourizes. The graph will show a steadily increasing temperature until it reaches the boiling point on the vertical axis (about 100°C). At this point, the temperature will level off as time continues to increase.

Theory: When a substance is heated, its temperature increases as it gains heat as per its heat capacity. However, when it changes state from solid to liquid or liquid to gas, its temperature remains constant as it is absorbing latent heat.

12.6.15 Distillation

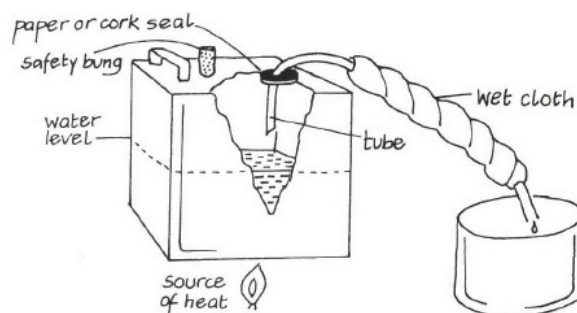

Materials: Metal can, cork/rubber stopper, plastic tubing, wet cloth, container, Heat Source

Procedure: Fill a container half way with water. Cut a hole in the top and fix a rubber stopper with a plastic tube through the center. Wrap a wet cloth around the tube and feed it into a can. Add a safety bung using rubber or cork to prevent against very high pressures within the container and place the container over the heat source.

Hazards: Make sure the safety bung is not too tight and that the container always has water inside.

Theory: Heating the can produces steam which is then cooled by the wet cloth. Steam condenses to produce water.

Applications: This method can be used to purify water.

12.7 Vapour and Humidity

Evaporation

12.7.1 Surface Area and Evaporation

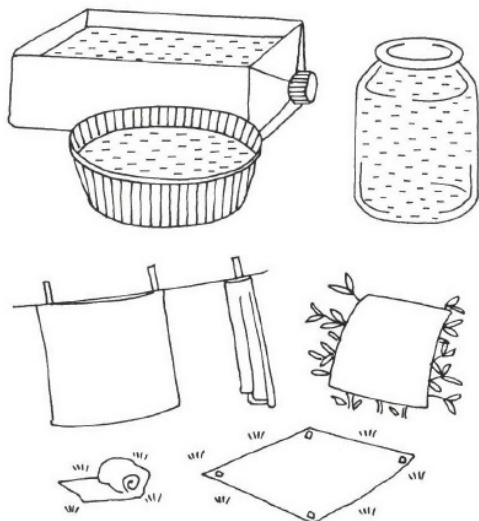

Materials: Open containers of different sizes, water

Procedure: Fill different containers with water and place them outside on a sunny day. Check the containers periodically to see which has lost the most water.

Observations: Containers with a larger surface area lose more water due to evaporation.

Applications: This is why we spread out our clothes in the sun after washing them. The greater the surface area, the more quickly water evaporates.

Humidity

12.7.2 Relative Humidity

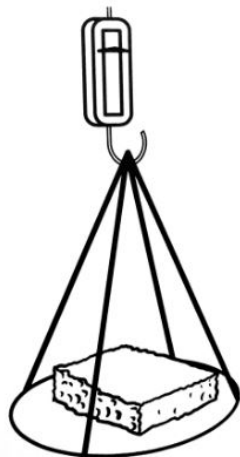

Materials: Sponge, Spring Balance, Scale Pans

Procedure: Weigh a dry sponge using a spring balance. Then wet the sponge so it is soaked but not dripping and weigh again to determine the weight of water added. Dry the sponge again and add $\frac{1}{2}$ or $\frac{1}{4}$ of the water that the sponge can hold.

Theory: The sponge represents the air. When soaked, it is said to be *saturated*, i.e. it contains 100% of the moisture it is capable of holding. When holding $\frac{1}{2}$ of that amount of water, it is 50% saturated, and so on.

12.7.3 The Hygrometer

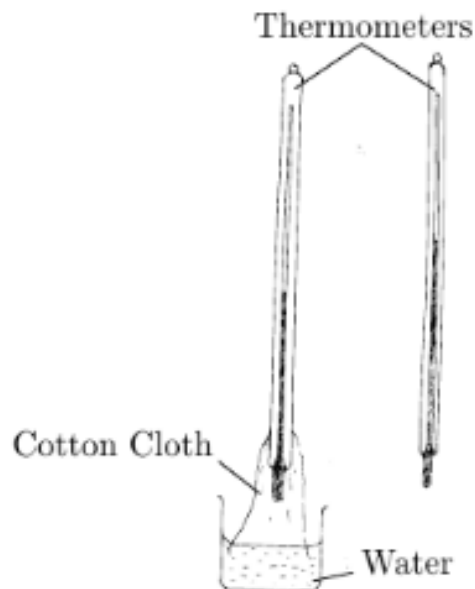

Materials: 2 mercury or alcohol thermometers, container of water, cotton cloth, thread

Procedure: Wrap one of the thermometers with the cloth, tie it securely with string, and dip it into the water. Remove from the water and tie the tops of both thermometers with thread. Holding the thread tightly, quickly spin the thermometers together over your head for at least 30 seconds. Read and record the temperatures on both thermometers.

Observations: The reading on the thermometer with the cloth drops.

Theory: When rotated the cloth loses water and is therefore cooled by evaporation. The amount of water that the cloth loses depends on the humidity of the air. By observing the difference between the temperature of the wet cloth and air, we can tell the relative humidity (a small difference implies a high relative humidity and vice versa).

12.8 Current Electricity

See also the Form II Chapter on [Current Electricity](#).

Potential Difference and Electromotive Force

12.8.1 Measuring Emf of a Cell

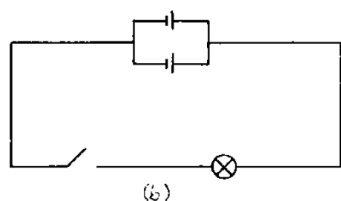
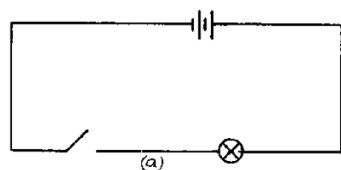

Materials: Dry cell batteries, speaker wire, voltmeter/multimeter

Procedure: Connect the terminals of the multi-meter to the terminals of the battery so that a voltage level is displayed. Connect two cells in series, i.e. positive terminal of one to negative terminal of the other. Then connect two cells in parallel, i.e. positive terminal of one to positive terminal of the other.

Questions: What difference is there in the voltage readings?

Observations: The voltage level is higher when the cells are in series (around 3 V) than when in parallel (around 1.5 V)

Theory: The potential difference in a cell or battery when no current flows out of the battery is the *electromotive force (e.m.f.)* of the cell. The voltage of two cells add together in series, but in parallel, it stays the same as that of a single cell.

Applications: In torches and car batteries cells are connected in series to get the required voltage. In cars, 12 volts are needed, so 6 cells are connected in series, since each cell carries only 2 V.

Electric Current and Resistance

12.8.2 Internal Resistance of a Cell

NECTA PRACTICAL

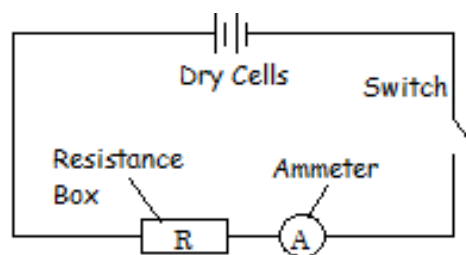

Materials: Dry cell, resistance box/rheostat, ammeter/galvanometer, speaker wire

Setup: Connect the circuit shown.

Procedure: Adjust the resistance box/rheostat to give 1 Ω . Read the current I on the ammeter. Repeat for different resistances (2 Ω , 3 Ω , 4 Ω , 5 Ω).

Questions: Plot a graph of resistance, R (vertical) against $\frac{1}{I}$ (horizontal). Find the slope and y -intercept.

Observations: According to Ohm's Law, $V = IR$. When accounting for internal resistance of a cell, this becomes, $V = I(R + r)$. Solving for R we get, $R = \frac{V}{I} - r$. Because $\frac{1}{I}$ is the value on the x -axis, we can see that this equation follows the standard $y = mx + c$ form, where the slope m in this case is the voltage V , and the y -intercept c is in this case $-r$ (crosses the y -axis at a negative value, though r itself is positive).

Theory: Cells have an internal resistance that opposes flow of current through them. This value can be obtained through experiment as outlined above.

12.8.3 Making a Potentiometer/Metre Bridge

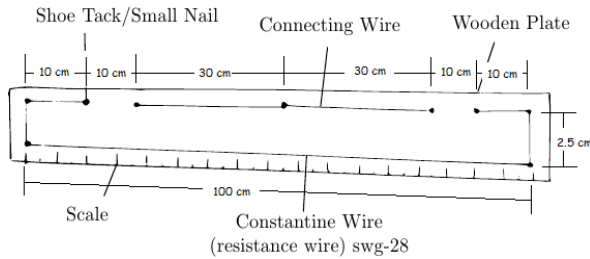

Materials: Wooden plate 110 cm × 4 cm, Constantine or nichrome wire, small nails, metre rule

Procedure: Fix nails into the wooden plate as shown in the figure. Use a metre rule to mark a cm scale along the bottom side and fix resistance wire between the nails, making sure the wire is tight. Use connecting wire to join the other nails as shown.

12.8.4 The Potentiometer

NECTA PRACTICAL

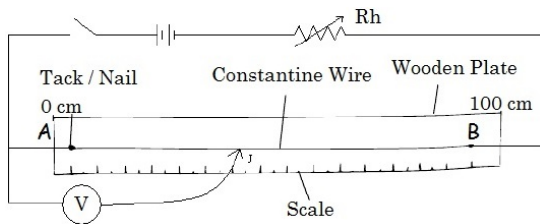

Materials: Potentiometer (see above), dry cells, resistance box/rheostat, voltmeter

Setup: Set up the circuit as shown by connecting 2 dry cells across the first gap in the potentiometer assembled above, and a rheostat across the second gap. Connect one lead of the voltmeter to one end of the resistance wire and leave the other lead free to move (J).

Procedure: Adjust the rheostat so that when J touches B, there is a near full deflection of the voltmeter. Now place the terminal J of the voltmeter 10 cm from side A. Record the voltage reading. Repeat for different values of AJ (20 cm, 30 cm, 50 cm, 70 cm).

Questions: Tabulate your results and plot a graph of voltage (V) against AJ. Calculate the slope of the graph.

Theory: From Ohm's Law, $V = IR$. However, resistance depends on many factors, including length l , resistivity ρ , and cross-sectional area A . Hence this equation can be rewritten as $V = \frac{I\rho l}{A}$. Because we are plotting against l , the slope of the graph is $\frac{I\rho}{A}$.

12.8.5 Wheatstone Bridge

NECTA PRACTICAL

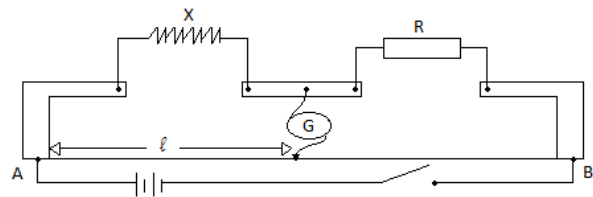

Materials: Metre bridge (see above), dry cells, galvanometer, resistance box, unknown resistor (e.g. 10 Ω)

Setup: Connect the circuit as shown by placing one *unknown* resistor (X) across the first gap of the metre bridge assembled above, and a resistance box (R) across the second gap. Connect 2 dry cells across either end of the resistance wire and a galvanometer attached at one end with its other terminal free to move as shown.

Procedure: Adjust the resistance box to 1 Ω and slide the jockey, J (free lead of galvanometer) along the resistance wire until the galvanometer gives a zero reading. Record the length l of AJ. Repeat for different values of the resistance box (2 Ω , 4 Ω , 7 Ω , 10 Ω).

Questions: Tabulate your values and plot a graph of resistance R against $\frac{1}{l}$. Find the slope and y -intercept of the graph and use them to determine the value of the unknown resistance X .

Theory: The balancing ratio for the wheatstone bridge states that $\frac{X}{l} = \frac{R}{(100-l)}$. Solving for R , we get $R = \frac{X}{l}(100-l)$, or $R = \frac{100X}{l} - X$. From this equation it can be seen that the slope of the graph is $100X$ and the y -intercept is simply the unknown resistance X .

Heat and Electric Current

12.8.6 Heating Effect of an Electric Current

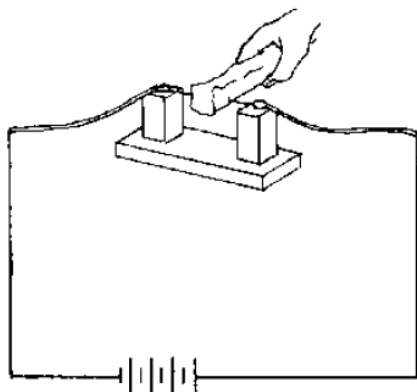

Materials: Styrofoam, dry cells, speaker wire, steel wool, wooden blocks

Setup: Set up the circuit as shown by connecting a thin strand of steel wool across two wire ends supported by wooden blocks.

Procedure: Wait a short time for the steel wool to heat up. It may begin to glow red. Press the Styrofoam gently across the steel wool.

Hazards: Don't touch the heated steel wool!

Observations: The steel wool easily cuts through the Styrofoam.

Theory: The electrical energy in the circuit has been converted into heat energy which melts the Styrofoam.

Applications: Electric iron, electric kettle, electric cooker

12.8.7 Electric Matches

Materials: Dry cells, steel wool, matches

Setup: Set up the circuit as above.

Procedure: Instead of using Styrofoam, wrap the steel wool around the head of a match and connect the circuit.

Observations: The match heats up and after a short time it ignites.

Theory: Electric current produces heat energy which lights the match.

12.8.8 Making an Electric Heater

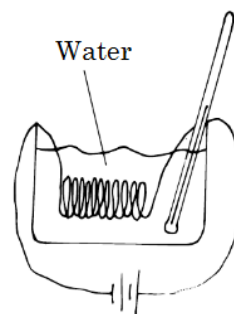

Materials: Nichrome (resistance) wire (1 m), paper, speaker wire, 2-4 dry cells, water container, thermometer (optional)

Procedure: Roll a piece of paper and coil the resistance wire around it so that the coils are close but not touching. Use speaker wires to connect the ends of the resistance wire to the terminals of the batteries. Place the coil of resistance wire into the container of water.

Hazards: Do not touch the water when current is flowing. If the heater is connected to the cells while not in the water, the wire can melt or burn other objects.

Observations: By touching the water container *on the outside*, it begins to warm up. If left for long enough, the water will begin to boil.

Theory: The electric heater converts electrical energy into heat energy. The larger the coils are, the more efficient the heater will be.

Applications: Boiling water, heating houses

12.8.9 The Fuse

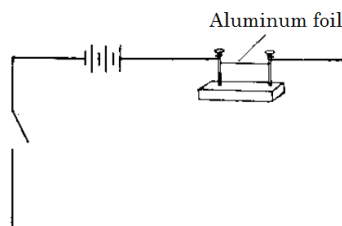

Materials: Power source, speaker wire, 2 small nails, small piece of wood, metal foil

Procedure: Hammer the nails into the wood about 5 cm apart. Connect wires to each nail and secure a thin strip of foil between them. Connect wires to the power source.

Observations: The foil will heat and eventually burn, breaking the circuit.

Theory: Foil has a very small cross-sectional area compared to that of a wire, so it has a low tolerance for current. If too much current passes through the foil, it will burn away.

Applications: Radios or other electrical devices to prevent large currents which could start fires.

Cells

12.8.11 Creating a Leclanche Cell

12.8.10 Opening a Dry Cell

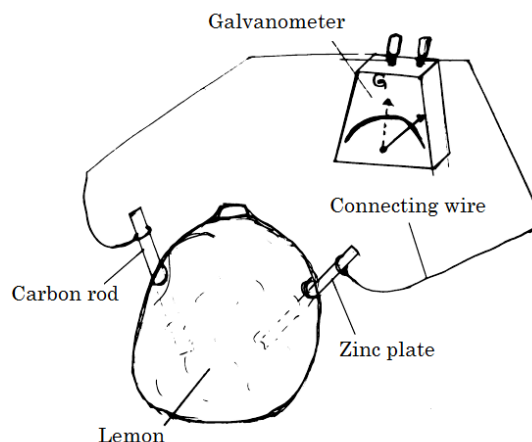
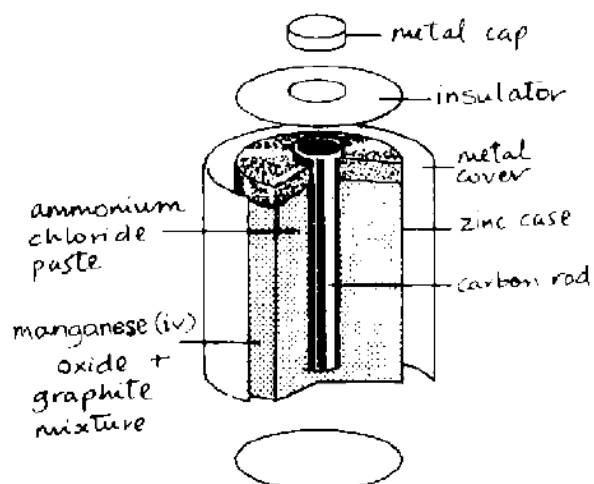

Materials: Dry cell battery, knife

Procedure: Remove the outer coating and cut the inside in half so the components can be seen clearly.

Hazards: The black powder found in the dry cell is poisonous and will also corrode metal - wash all tools well that touch the powder.

Observations: The black rod in the centre is a carbon rod (graphite). The black substance contains manganese (IV) oxide and ammonium chloride paste. There is a zinc plate surrounding the black powder.

Theory: The electrical energy is produced by a chemical reaction between the zinc and the ammonium chloride paste.

Applications: Zinc cases and carbon rods may be used for other activities.

Materials: Lemons, zinc plate and carbon rod from old dry cell (see above), connecting wires, galvanometer, bulb

Procedure: Make two holes in a lemon and insert the carbon rod and zinc plate into the holes. Connect the lemon to the galvanometer using connecting wires and notice any deflection that may occur. Repeat for several lemons by placing them in series and in parallel.

Observations: The deflection increases with the number of lemons placed in series. With enough lemons, the bulb will light up.

Theory: Electric current can be produced from different cells - dry and wet. Wet cells can be made from natural foods such as lemons, Irish potatoes and salts which produce electric current based on the principle of Leclanche cells.

Physics Activities for Form IV

13.1 Waves

Introduction to Waves

13.1.1 String Waves

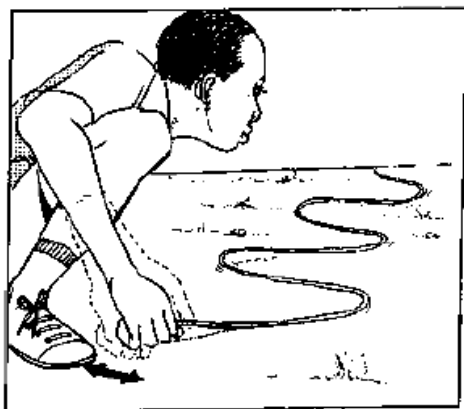

Procedure: Take a piece of rope about 6 m long.

Hold it at one end and jerk it sideways.

Questions: Draw a sketch of what you observe.

Theory: The jerking of the rope acts as a source of disturbance which travels along the rope. The direction of motion of the wave is perpendicular to the direction of jerking, so this is a *transverse wave*.

13.1.2 Flick-Sticks

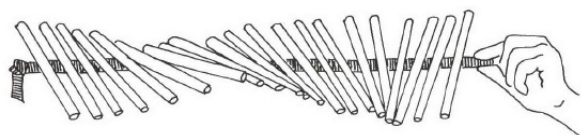

Materials: Straws or toothpicks, rubber strip or tape, glue

Setup: Cut the straws to be the same length or use toothpicks. Glue them to the tape/rubber strip. A tape of 3 metres works well.

Procedure: Twist or flick the strip to set off waves.

Notes: Experiment using different lengths of sticks and rubber to create good waves.

13.1.3 Water Waves



Materials: Plastic bag, ink/food colour, water, bucket

Procedure: Use ink or food colour to colour water in a bucket and allow it to come to rest. Fill a plastic bag with water and poke a small hole in the bottom. Raise the bag so that drops of water fall on the surface of the coloured water.

Observations: You can see circular waves spreading out rapidly.

Theory: The drops disturb the water. The disturbance spreads out in concentric circles from the centre. These are water waves.

13.1.4 Energy from Waves

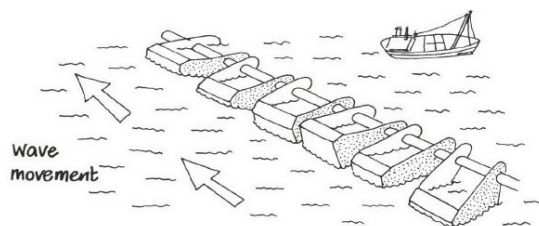

Materials: Stick, floats (wood or card), basin of water

Procedure: Attach several small floats to a long stick as shown. Place in a large basin of water and generate waves with your hand.

Observations: The floats oscillate up and down on the waves.

Theory: Waves carry energy which can be seen in other objects and converted into electrical energy.

Properties of Waves

13.1.5 Water Bottle Sine Wave

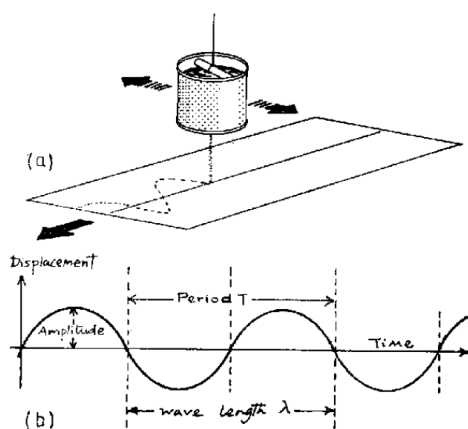

Materials: Water bottle/tin can, pin, coloured water, string

Procedure: Fill a water bottle with water (colour helps to see) and poke a small hole in the cap. Tie a string around the bottle. Walk in a straight line at constant speed while swinging the upside-down bottle from side to side.

Observations: The pattern produced is a sine wave.

Theory: The oscillation of the bottle spans its *displacement*, while walking at constant speed shows the *time*. Amplitude, wavelength and period may be seen from the wave produced.

Notes: Alternately, suspend an oscillating tin can with a hole in the bottom and slowly pull a long sheet of newspaper at constant speed below it.

13.1.6 Student Waves

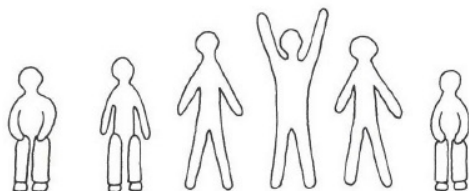

Procedure: Students crouch down in a line or circle. One by one in succession, they stand up, making a wave of students.

Observations: It is not easy to see the wave if you are a part of it!

Theory: The wave carries energy as it passes through the students, but each individual student does not travel with the wave.

13.1.7 Transfer of Energy

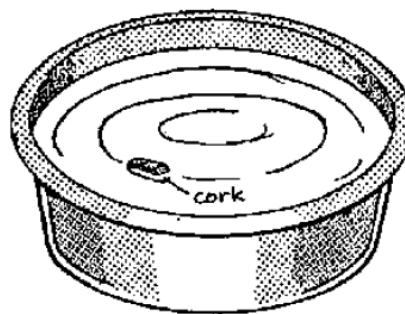

Materials: Small piece of wood/Styrofoam, bowl of water, straw/dropper

Procedure: Put a small piece of wood or Styrofoam on the surface of water in a bowl. With a dropper or straw, release a few drops of water onto the centre of the water surface.

Observations: The water waves move from the centre outwards but the pieces of light material do not travel with the wave.

Theory: Energy travels with the wave. However, the particles of the wave-transmitting medium (e.g. water) do *not* travel with the wave, they only oscillate up and down.

Types of Waves

13.1.8 Slinky Spring

Materials: 2 m of flexible steel/copper wire, long rod or stick (3 cm diameter or more)

Setup: Hold one end of the wire against the rod and coil the wire around the cylinder, keeping coils close together.

Procedure: Have a student hold one end of the spring and stretch the slinky slightly so the coils separate. Next, hold the slinky flat on the floor and move one end quickly from side to side while the student holds the other end stationary. Move your hand back and forth, pushing and pulling the spring. Move the slinky to one side then back to the center only once. Observe the waves generated for each case.

Observations: The transverse wave progresses by alternating crests and troughs, oscillating *perpendicular to the direction of the disturbance*. The longitudinal wave progresses by pushing and pulling *in the direction of the disturbance*. Transverse waves trade crests and troughs when reflected.

13.1.9 Transverse Pendulum

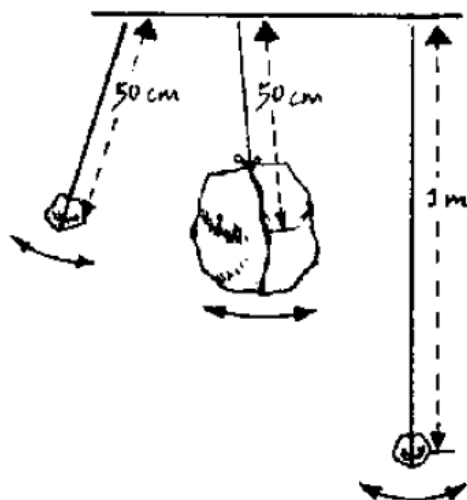

Materials: Stones of different sizes, string

Procedure: Tie a stone to the end of a string 50 cm long. Fix the other end and cause the pendulum to oscillate (no more than 10°). Record the time for 20 oscillations and find the frequency (Frequency = number of oscillations \div time). Replace with a heavier stone and repeat. Change the length of string to 100 cm and repeat.

Observations: The frequency is independent of mass, but depends on the length of the string.

13.1.10 Longitudinal Pendulum

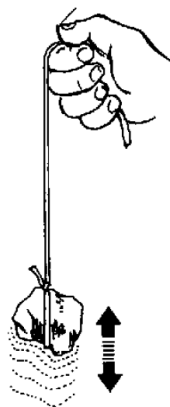

Materials: Rubber bands, stones

Procedure: Tie a stone to one end of a rubber band and hold the other end. Lift the stone and release so that it oscillates. Record the time for 20 oscillations and find the frequency. Repeat by varying the length of the rubber band and the mass of the stone.

Observations: The frequency is independent of mass but depends on length.

13.1.11 Longitudinal Student Waves



Procedure: Line up a group of students and ask each student to place his/her hands on the shoulder of the student in front. Tell the last student to push forward.

Observations: A longitudinal wave moves through the queue.

Behaviour of Waves

13.1.12 Construction of a Ripple Tank

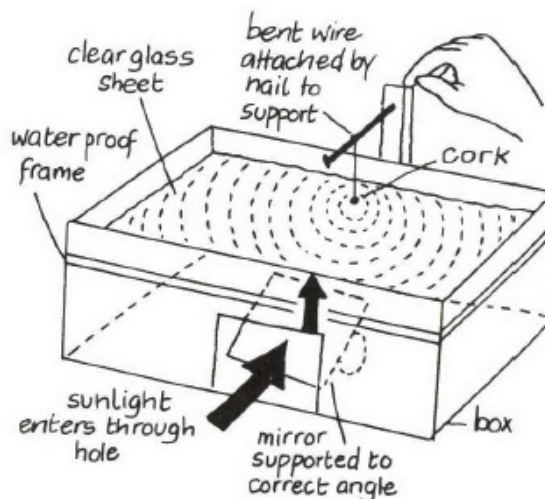

Materials: Sheet of glass, wooden/plastic/glass strips, waterproof glue, large box, mirror, wooden support, wire, string, small object (e.g. cork or eraser)

Setup: Glue the strips to the glass sheet using waterproof glue to create a shallow glass-bottomed dish. Arrange the mirror in the box so that it can direct light up through the glass and project an image of the ripples on a wall.

Procedure: To create circular waves dip the cork once into the water or tap the support.

13.1.13 Using the Ripple Tank

Materials: Spherical ball, ruler, [Using the Ripple Tank](#), slabs of glass/other barriers

Procedure: Use different objects to observe various behaviours of the waves produced, such as reflection, refraction, diffraction and interference.

Observations: When a round ball is used, circular waves are produced, while the ruler produces a plane wave. If a barrier is placed in front of the wave, it is reflected back on itself or in a new direction. When passing between two barriers, the wave diffracts and changes form. A plane wave becomes a circular wave and two diffracted waves interfere to form points of constructive and destructive interference.

Reflection of Waves

13.1.14 Reflection of Water Waves

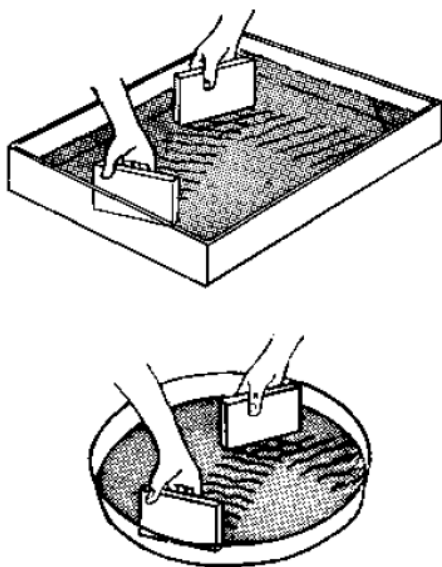

Materials: Large container/dish, coloured water, blocks of wood, plastic/metal

Procedure: Place a straight metal or plastic barrier in the dish containing coloured water. Touch the surface of the water with a rectangular block of wood repeatedly in equal time intervals.

Observations: Parallel waves move across the dish and rebound from the barrier.

Theory: This behaviour is called *reflection* of the waves. When the angle of the barrier is changed, the angle of reflection remains the same as the angle of incidence.

Applications: The barrier acts as a reflector just as a mirror is a reflector of light.

13.1.15 Reflection of Sound Waves



Procedure: 2 students stand on either side of a wall. One student whispers into a cone while the other listens through another cone. Repeat while holding a piece of smooth cardboard as shown. Change the position of the cardboard.

Theory: Initially, no sound is heard. The cardboard reflects the sound waves to the listener, which then allows sound to reach the listener.

13.1.16 Reflection in a Rope

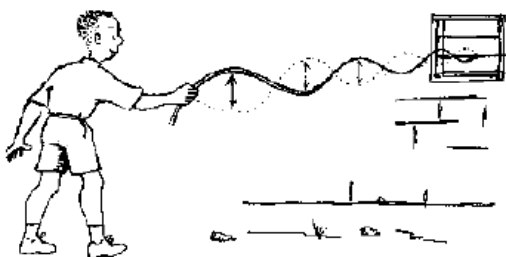

Procedure: Tie a rope about 4 metres long to a fixed bar of a window. Hit the rope with a stick. Repeat by jerking the rope up and down.

Observations: An impulse travels along the rope and comes back.

Theory: When the impulse hits the fixed end of the rope, it bounces off and comes back as shown by the dotted lines in the figure. The reflected impulse is the same shape as the original, but *inverted*.

13.1.17 Reflection in a Hose Pipe



Procedure: Take a long piece of garden hose pipe. Listen at one end while another person whispers into the other end.

Observations: The sound is heard more distinctly.

Theory: When a person speaks into the pipe, sound waves are sent into the pipe and reflected off the walls of the hose. These waves are directed to the other end where they can be heard.

Applications: Glass fibres, or fibre optic cables, employ the same principle using light. Light is reflected along the walls of a glass fibre from one end to the other. These cables are used for telephones, televisions, internet cables, etc.

Sound Waves

13.1.18 Sound from a Ruler

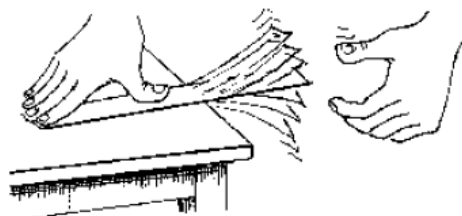

Procedure: Tightly hold a ruler on a table with its free end extending over the edge. Cause the free end to vibrate and listen to the sound. Repeat for different extending lengths of the ruler.

Questions: How does the sound change with extending length of the ruler?

Observations: When the vibrating length is reduced, a higher pitch and quieter sound is heard and the vibrations become faster and faster. When the vibrating length is increased, a lower pitch and louder sound is heard.

Theory: The short lengths cause small masses of air to vibrate with small amplitudes and so produce a soft sound. The long lengths vibrate large masses of air with large amplitudes, making a louder sound.

13.1.19 Straw Kazoo

Materials: Straw, scissors

Procedure: Cut one end of a straw so that it comes to a point like an arrowhead. Blow into the straw to produce a sound like a kazoo or vuvuzela. While blowing, cut short lengths of the free end of the straw continually until it is very short.

Observations: As you cut off lengths of the straw, the sound produced becomes a higher pitch.

Theory: Vibrations in the long straw have a low frequency and hence low pitch, while those in the short straw have a high frequency and hence high pitch.

13.1.20 Sound Sandwich

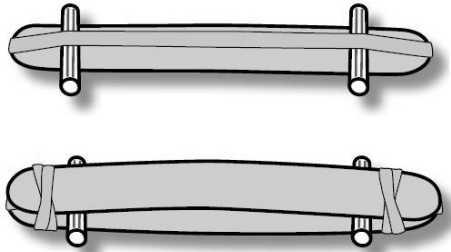

Materials: Straw, scissors, 2 tongue depressors, 2 small rubber bands, 1 wide rubber band

Setup: Stretch a wide rubber band lengthwise across a tongue depressor. Cut two small pieces of straw (about 3 cm) and place them under the rubber band about a third of the way from either end. Cover with the other tongue depressor and fix the two together at the ends with the small rubber bands.

Procedure: Blow through the sticks (not the straws) to hear a sound. Change the position of the straws and blow again.

Theory: The sound produced is caused by vibrations in the wide rubber band. The pitch depends on the length of rubber band between the two straws. A longer length produces a lower pitch, while a shorter length produces a higher pitch.

13.1.21 Sound Vibrations



Materials: Open tin, paper, rubber band, sand

Procedure: Cover a one end of an open tin with a membrane (paper) and fasten it using a rubber band. Spread fine dry sand on the membrane. Speak a soft and loud sound into the tin from the bottom while a friend watches the sand.

Observations: The louder the sound, the larger the amplitude of the vibrations.

Theory: The air underneath the membrane gets disturbed by the sound waves which in turn disturb the membrane and make it vibrate. This shows that sound travels as a vibration.

13.1.22 Drum Vibrations

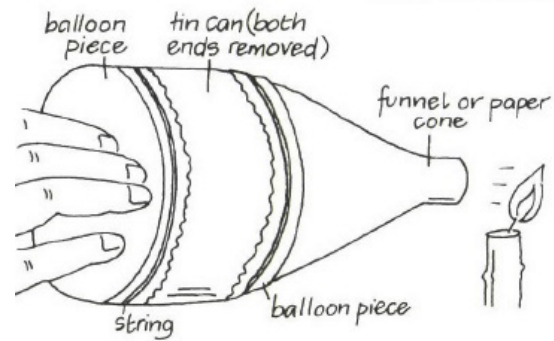

Materials: Tin can, balloon, string, funnel, candle

Setup: Remove the ends from the tin. Tie the balloon pieces to the tin as shown and attach the funnel.

Procedure: Place the drum in front of a lit candle and tap the drum softly and then harder.

Observations: When the drum is tapped hard, it can put out the candle.

Theory: Sound vibrations are carried through the air in the can, making the other sheet vibrate. The funnel concentrates the sound vibrations so that the air from the funnel can put out the candle.

13.1.23 Knocking a Water Tank

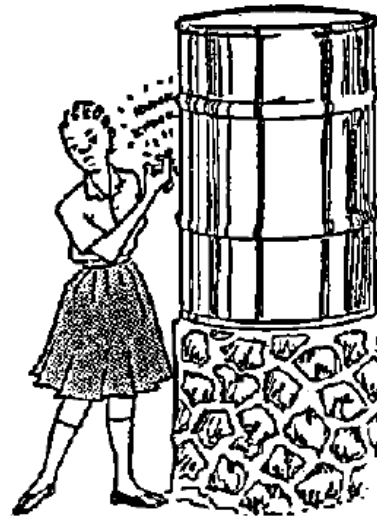

Procedure: Gently knock the side of a water tank from the top downwards to the bottom and listen to the tones.

Observations: A loud sound is heard at the top, and a soft sound at the bottom.

Theory: The knock causes the drum to vibrate. At the top, the knocking vibrates the air inside the tank giving a loud sound. At the bottom, the knocking vibrates water inside the tank giving a soft sound.

Applications: This can be used to check the presence of liquids in tanks or large containers.

Propagation of Sound Waves

13.1.24 String Telephone



Materials: 2 tin cans, string

Procedure: Punch a small hole at the centre of the bottom of each empty can. Connect the cans with a long string knotted inside each can. Hold the cans so that the string is stretched. One student talks into one can while another listens through the other can.

Observations: The speaker can be heard distinctly, even with the other ear closed with a finger.

Theory: Sound travels through the string (as a medium) from one can to the other.

13.1.25 Sound in Air

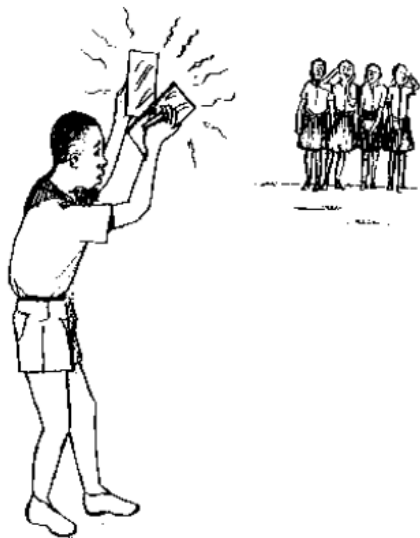

Procedure: One student stands about 100 m from the class and makes sound by clapping two metal lids together.

Theory: The sound is transmitted from the source to the class using air as a medium.

13.1.26 Sound in a String

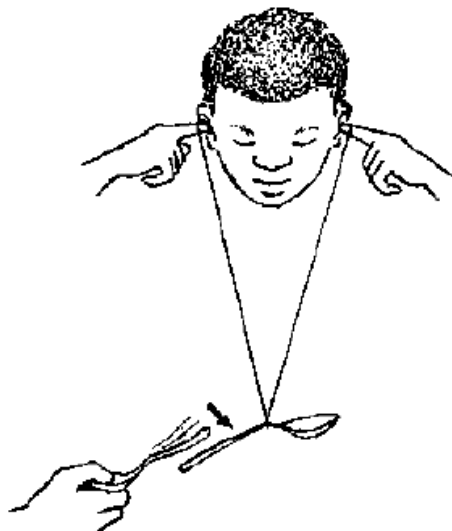

Materials: Thread, 2 spoons

Procedure: Tie a metal spoon at the middle of a 1 m cotton thread. Wind each end of the thread around a fingertip and press the fingertips into your ears. Bend down so the spoon hangs freely and let someone hit the spoon slightly with a nail or another spoon.

Observations: A chime is heard like that of a church bell.

Theory: Sound travels through the string to your ears. Sound travels better in strings than in air.

13.1.27 Sound in Wood

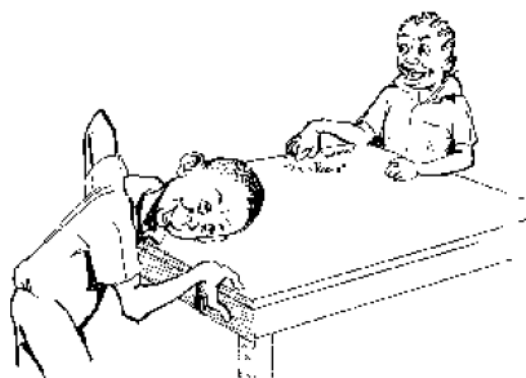

Procedure: Place your ear against one edge of a table while a friend is knocking the opposite edge slightly. Listen to the sound through air and the sound through the table.

Observations: The sound traveling through the table is heard more distinctly than when heard through the air.

Theory: Sound travels better in wood than in air.

13.1.28 Sound in Metal

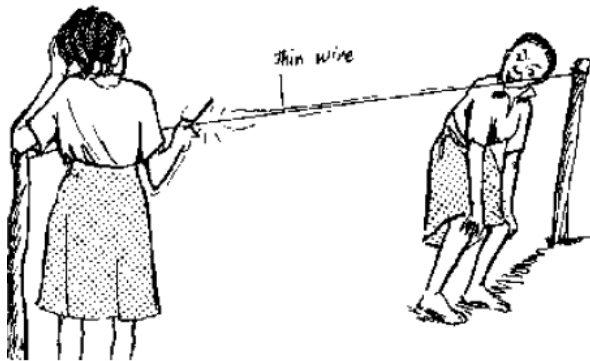

Procedure: Fix a long thin wire to two posts about 5 m apart. One student scratches the wire while the other listens both in air and by placing an ear against the wire.

Observations: Nothing is heard unless the student's ear is placed against the wire.

Theory: Sound travels better in metal than it does in air.

13.1.29 Sound in Water



Materials: Plastic bucket, water, 2 stones

Procedure: Fill a plastic bucket with water and knock 2 stones against each other *in the water* while another person puts an ear close to the bucket.

Observations: The sound is heard more loudly when listening near the bucket.

Theory: Sound travels better in water than in air.

13.1.30 Doppler Whirl

Materials: Mobile phone, sock, string

Procedure: Program a ring tone on a mobile phone that repeats a single note for a period of 20 seconds or more. Place the phone in a sock, tie it to a string and swing it rapidly around your head so that the phone moves in a large circle.

Observations: As the phone moves towards the students, they will hear the pitch increased, and as it moves away, they will hear the pitch decreased. The person swinging the phone hears no noticeable difference in pitch.

Theory: This is known as the Doppler effect. When the source of a sound is moving, the sound waves in front of the source become compressed, making for shorter wavelengths and higher frequency. The sound waves behind the source are extended (like they are being stretched), so the wavelength is longer and frequency lower.

Applications: The same effect is seen for sirens of an ambulance or emergency vehicle approaching and moving away from you.

Musical Instruments

13.1.31 Bottle Orchestra



Materials: 4 bottles, water

Procedure: Fill four equal bottles with different levels of water and blow into the bottles one after another, listening to the tones produced.

Observations: The shorter the air column, the higher the tones.

Theory: Adding water shortens the height of the column of air, shortening the wavelength and increasing the frequency.

Applications: Organ, flute

13.1.32 Bamboo Organ

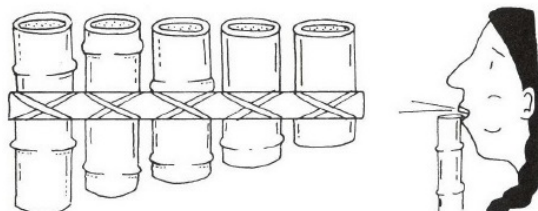

Materials: Pieces of bamboo, string/tape

Procedure: Hollow out the bamboo pieces and attach them as shown. The length of the pipes determines the pitch of the sound.

13.1.33 Bamboo Flute

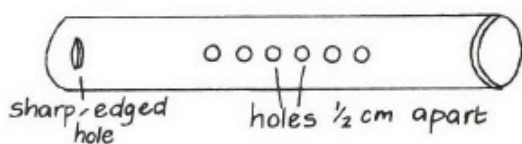

Materials: Bamboo tube (1.5 cm diameter, 30 cm length)

Procedure: Hollow out the bamboo tube and dry it until its colour changes to yellowish-brown. Make a mouth-piece and row of holes as shown. Blow air into the mouth-piece while closing some of the holes with your fingers.

Observations: Different tones are produced by the flute as you remove your fingers from different holes.

Theory: The pitch of the tones depends on the distance of the first open hole from the mouth-piece, i.e. the closer the whole hole is to the mouth-piece, the higher the tone produced. Thus the tone produced is determined by the vibration of air in the column between the mouth-piece and the first uncovered hole.

13.1.34 Marimba

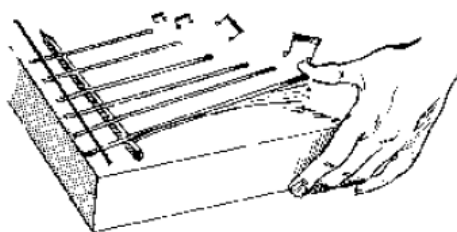

Materials: Bicycle spokes, piece of wood, pencil

Setup: Cut bicycle spokes into different lengths and arrange them on a piece of wood. Fix them with another spoke across as shown. Lift the spokes by inserting a pencil underneath them.

Procedure: Pluck the free ends one after another and listen to the tones produced.

Theory: Plucking causes the spokes to vibrate and produce sound. The longer the spoke, the lower the tone.

13.1.35 Xylophone



Materials: Wooden box, wooden bars, string, sticks

Procedure: Make a wooden box with the bottom and top sides open. Take timber bars of different types and thickness. Drill four holes into each bar and pass two strings to hold all the bars together on the top of the wooden box. Beat the bars in turn using two sticks.

Observations: Different sizes of bars give different tones and different materials of the same thickness give different tones.

Stationary Waves

13.1.36 Sonometer (One-String Guitar)

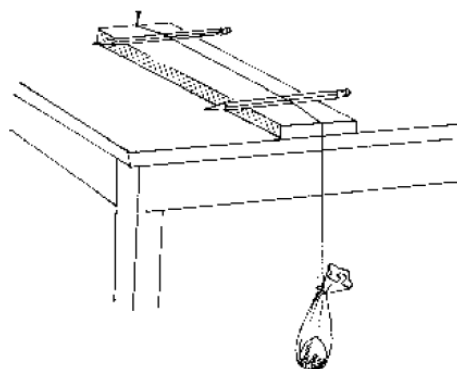

Materials: Soft wood board, string or thin wire, nail, plastic bag, stones, 2 pencils

Setup: Place a soft board on a table. Fix a string with a nail to one end of the soft board and tie a heavy mass of stones to the other end so that it hangs below the edge of the table. Insert two pencils under the thread so as to raise the thread off the board.

Procedure: Pluck the thread between the two pencils. Repeat by varying the distance between the pencils and the mass hanging.

Observations: Reducing the distance between the pencils produces a higher tone. Increasing the mass produces a higher tone.

Theory: The tone produced by the vibrating string depends on its vibrating length and the tension in the string.

13.1.37 Resonance Tube

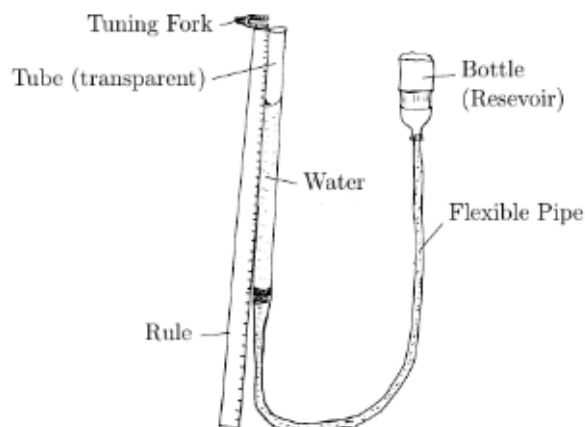

Materials: Fluorescent tube (tube light), thick rubber tubing, two 1.5 L plastic water bottles, super glue, wax, tuning fork, retort stand, bucket, water, long stick, knife, metre rule, rubber or cork, piece of cloth

Setup: Carefully cut the rims off both sides of the tube and clean it with a cloth on a long stick. Cut the bottom 5 cm off one bottle (bottle 1) and the top 5 cm off the other (bottle 2). Make a hole in each bottle cap and insert the rubber tubing through both holes. Attach one end of the pipe with glue and wax to the inside top of bottle 2. Hold the tube vertically with a metre rule using a retort stand. Raise bottle 1 vertically until you have created a U-shape and pour water into bottle 1.

Hazards: Do not touch the fluorescent dust in the tube; it is poisonous.

Procedure: Strike the tuning fork with a soft material (e.g. rubber) and place it at the top of the tube. Raise and lower the water level in the tube by changing the vertical position of bottle 1. Repeat for different tuning forks, noting the fundamental note and overtone.

Observations: The tube can be heard resonating at two or more water levels. The lowest water level is the fundamental and each smaller water level is a higher harmonic.

Theory: The length of the tube from the water to the top can be used to calculate the speed of sound in air. Resonance frequency occurs when the natural frequency of the air column is equal to the forced frequency from the tuning fork.

13.2 Electromagnetism

13.2.1 Induced Magnetic Field from a Coil

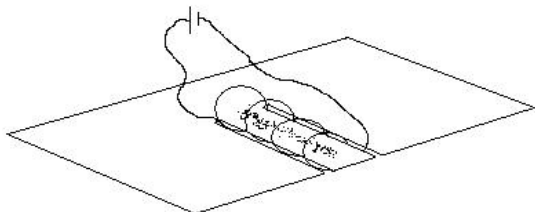

Materials: Dry cell, 50 cm of wire, cardboard, iron wool

Procedure: Coil a wire through a piece of cardboard and connect to a dry cell. Use the iron wool to sprinkle iron filings inside the coil and around either end.

Observations: The filings create a single solid line the length of the coil, spreading out at each end.

Theory: A coil of wire creates a single strong magnetic field inside it in one direction. At the poles, the field spreads out again. The Right Hand Rule can be used to find the direction of the field.

13.2.2 Induced Magnetic Field from a Wire

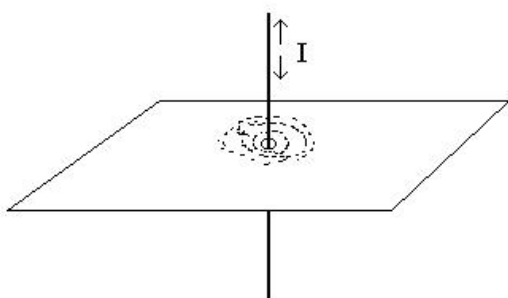

Materials: Dry cell, straight wire, paper, iron wool

Procedure: Cut a hole in the paper so that the wire passes vertically through the middle and the paper lies flat. Connect the wire to the dry cell. Sprinkle iron filings across the paper.

Observations: The filings form concentric circles around the wire.

Theory: Current in a straight wire produces a magnetic field around the wire in concentric circles. The filings align themselves in the field to show the lines of force. the Right Hand Rule can be used to find the direction of the field.

13.2.3 Making a Galvanometer

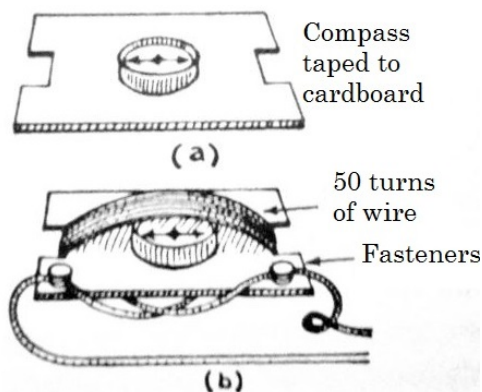

Materials: Cardboard, tape, compass, copper wire, fasteners/thumb pins

Setup: Tape the compass to the cardboard and wind 50 turns of wire around it, leaving about 50 cm free at each end. Fix the wire using fasteners. Scrape the insulation at the free ends of the wire.

Procedure: Connect to a dry cell. Still watching the compass, reverse the terminals of the wires.

Theory: The compass deflects, revealing the presence of electric current. Reversing the connection changes the direction of current and thus magnetic field.

13.2.4 Spinning Compass

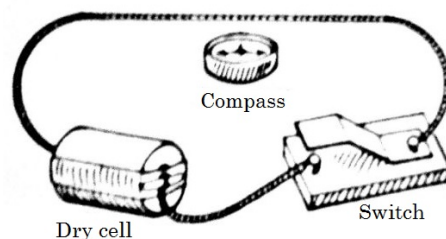

Materials: Power source, wire, compass/magnetized pin

Procedure: Connect the wire to the power supply. Run the wire over the compass in a straight line.

Observations: If the current is DC, the compass will turn to face a new direction. If AC, the compass will spin back and forth quickly.

Theory: Current in a straight wire creates a magnetic field around the wire. DC current produces a steady magnetic field in one direction (circular), so the magnet aligns itself with the field. AC current produces a constantly shifting field, so the compass will spin, trying to align itself as the field changes direction.

13.2.5 Force on a Current-Carrying Conductor in a Magnetic Field

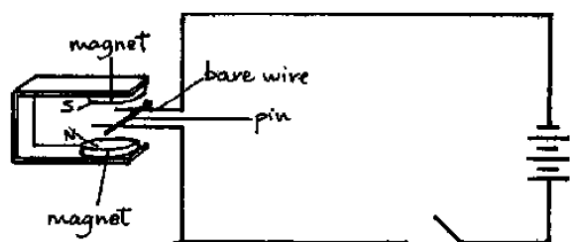

Materials: Dry cells, pin, 2 speaker magnets, wire, switch

Procedure: Connect the circuit as shown and place a pin across the straight bare wires between the poles of the magnets and close the switch *for a short time only*.

Observations: The pin rolls along the straight wires.

Theory: The pin closes the circuit and thus has current running through it. The magnetic field around the pin produces a force on the current in the pin, causing it to roll.

Applications: Electric motors, loudspeakers

Electromagnetic Induction

13.2.6 Creating Current in a Wire

Materials: 50 cm of wire, ammeter or bulb, strong magnet

Procedure: Coil the wire to make a solenoid, connecting the free ends to an ammeter or bulb. Use a bar magnet and pass it through the solenoid.

Observations: As the magnet passes through the coil, the ammeter or bulb shows a current. When the magnet stops moving or leaves the coil, the current ceases.

Theory: A magnetic field moving perpendicular to a conductor induces a current in the conductor. The current strength can be increased by increasing the number of coils or by using a stronger magnet.

13.2.7 Creating Alternating Current

Materials: Syringe, 50 cm of wire, strong bar magnet, ammeter/bulb, small piece of cloth

Procedure: Wrap the wire around a syringe multiple times and connect the ends to an ammeter or bulb. Place a small wad of cloth in the bottom of the syringe and insert the magnet. Cover the opening with your thumb and shake. The cloth and your thumb protect the magnet as it bounces back and forth, creating an alternating current in the coil.

Generators

13.2.8 Simple Motor

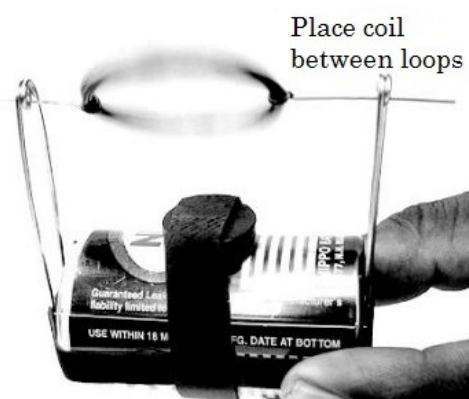

Materials: Dry cell, insulated copper wire (1 m), 2 paper clips/safety pins, rubber bands, speaker magnet

Setup: Make several turns of copper wire around the dry cell, leaving about 5 cm on either side. Use a knife to remove the insulation from all sides of the wire on one end, and 3 sides on the other end. Bend two paper clips as shown to make supports for the wire or use safety pins.

Procedure: Attach the paper clips/safety pins to either end of the dry cell using a rubber band. Lay the copper wire coil across the paper clip holders. Bring the coil close to a speaker magnet.

Observations: The coil begins to turn when brought close to the magnet.

Theory: The magnetic field applies a force to the current-carrying wire following Fleming's left-hand rule and causes the loop to spin. If the current is increased the coil spins faster, showing the force is proportional to the current. If the current is reversed the coil will rotate in the other direction. If there is a stronger magnet the coil spins faster, which shows the force is proportional to the magnetic field strength. If all of the insulation is scratched off from both sides then the loop will not spin but will instead reach an equilibrium position where the force acting on the top and bottom of the loop are balanced.

13.2.9 Wind Turbine

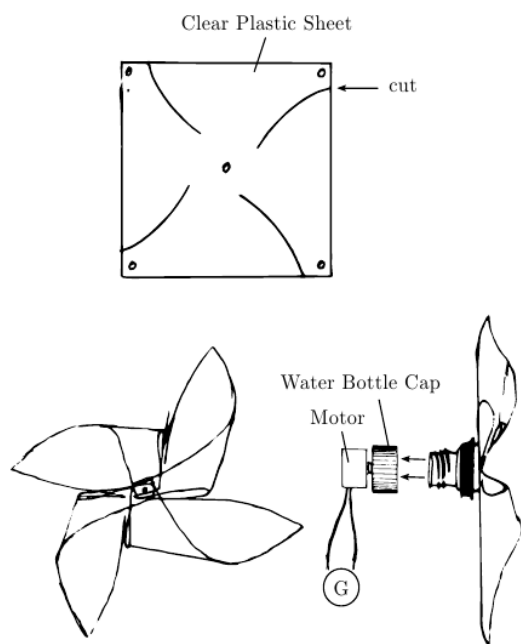

Materials: 30 cm × 30 cm flexible plastic sheet, pin, scissors, super glue, plastic water bottle, small motor (e.g. from car stereo), connecting wires, galvanometer

Propeller: Make 5 small holes in the plastic sheet - one at each corner and one in the middle. Cut along the curved lines shown. Fold each corner towards the centre so that all five holes are aligned and glue them in place. Cut the top off of a water bottle just below the lip where the cap sits. Glue the bottle top to the propeller as shown.

Generator: Make a small hole in the centre of the bottle cap using a pin. Glue the top of the cap to the motor wheel so that the two spin together evenly.

Setup: Screw the propeller onto the generator like closing a bottle. The propeller should be able to turn freely on the motor. Connect the terminals of the motor to the terminals of the galvanometer.

Procedure: Hold the propeller upright into the wind so that it spins.

Observations: The galvanometer will deflect to show that a current is being created in the wire.

Theory: Mechanical energy (wind) is converted into electrical energy (electric current) using a generator. The generator uses a magnet and motion to produce an electric current.

Applications: Sustainable energy sources

13.2.10 Water Turbine

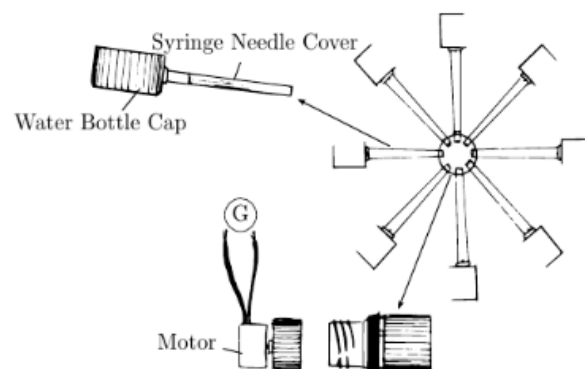

Materials: Plastic bottle, small motor (e.g. from car stereo), super glue, [Heat Source](#), heated nail or soldering iron, 9 water bottle caps, 8 syringe needle caps, scissors, water and pitcher, connecting wires, galvanometer

Water Wheel: Using a hot nail or soldering iron, melt the open end of a syringe needle cap to the side of a water bottle cap to create a sort of spoon. Repeat 7 more times for a total of 8 pieces. Cut the top off a water bottle just below the lip which holds the cap. Melt a plastic cap over the cut end of the bottle top so that the threaded side is open. Use the hot nail or soldering iron to melt 8 holes evenly around the side of this central bottle cap. Insert the 8 spokes into the holes so that they create an 8-spoke wheel with all of the cups facing in one direction at equal distances from the centre. Melt the plastic around each spoke to secure them in place.

Generator: Make a small hole in the centre of the bottle cap using a pin. Glue the top of the cap to the motor wheel so that the two spin together evenly.

Setup: Screw the water wheel onto the generator like closing a bottle. The water wheel should be able to turn freely on the motor. Connect the terminals of the motor to the terminals of the galvanometer.

Procedure: Pour water from a pitcher or spout and place the water wheel under the water so that it turns vertically.

Observations: The galvanometer will deflect to show that a current is being created in the wire.

Theory: Mechanical energy (falling water and subsequent rotating water wheel) is converted into electrical energy (electric current) using a generator. The generator uses a magnet and motion to produce an electric current.

Applications: Sustainable energy sources

13.2.11 Inverter: Converting DC to AC

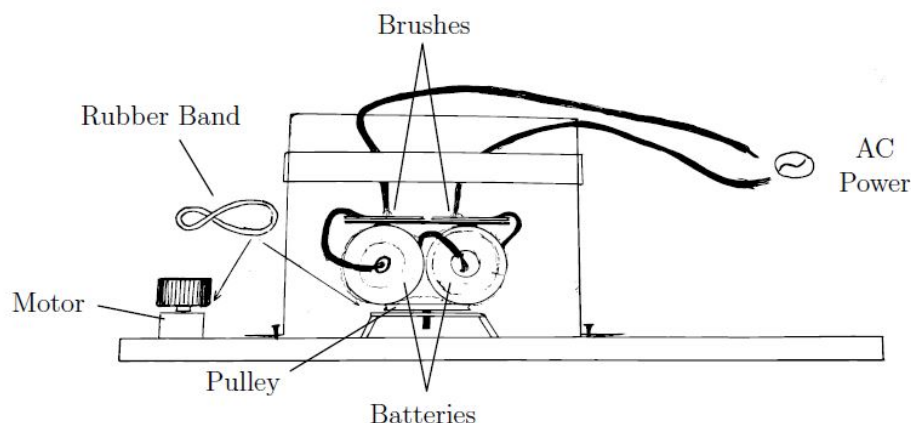

Materials: 4 dry cells, aluminum outer coating of dead dry cell, thin cardboard, super glue, soldering iron and flux, several small nails, connecting wires, board at least 30 cm long, bulb or galvanometer, scissors, knife, retort stand, small motor, horizontal pulley, rubber band, pliers, multimeter

Setup: Attach the pulley and motor near one end of the board so that they are free to rotate horizontally as shown. Connect the pulley and motor using a rubber band so that they rotate together. Solder a connecting wire from the positive terminal of one dry cell to the negative terminal of another so that they are connected in series but still packaged together side-by-side. Glue the battery pack on its side to the centre of the horizontal pulley. Glue a small 5 cm square piece of cardboard on top of the battery pack. Mark the centre of rotation of the pulley and battery pack system on the cardboard. Take a piece of aluminum from a dead dry cell and break it into 2 equal pieces (5 cm × 3 cm) using pliers. Glue the pieces to the cardboard leaving a small space between them so that the hole marking the centre of rotation can be seen. Solder or glue a short connecting wire from the free end of one battery to one of the aluminum plates. Repeat for the other battery and aluminum plate. Check connections using a multimeter. Cut a piece of cardboard 10 cm × 4 cm and fold it in half the long way. Cut two very small holes in the center of the folded edge about 2 cm apart. Insert connecting wires into each hole so that they stick out about 2 cm. Remove the insulation from the wires so that the copper ends form brush shapes and are free to bend slightly. Extend the connect-

ing wires to a bulb or galvanometer and solder or glue the ends to the terminals.

Check the circuit using a multimeter and 2 dry cells across the brush ends. Suspend the bulb/brush circuit about the rotating metal plates so that the wire brushes just touch the metal plates. If each brush is touching a different metal plate, the bulb or galvanometer should indicate a current.

Procedure: Touch the wire brushes to opposite plates to show that a direct current is flowing and the bulb/galvanometer shows a single direction of current. Switch the plates that the brushes are touching to show that, again a direct current is flowing in the opposite direction as before. Connect the motor to the batteries so that the system rotates under the brushes.

Observations: When the metal plates are rotating under the brushes, the galvanometer changes direction quickly. The behaviour of the galvanometer/bulb is different depending on whether the plates are rotating.

Theory: The galvanometer changes direction because the direction of current is changing every time the plates switch brushes. The system is converting direct current (DC) of the battery pack to alternating current (AC) in the bulb or galvanometer.

Notes: Normally, alternating current changes direction 80 times per second, which we cannot see with our eyes. Therefore, the difference between AC and DC is not visible in a normal household or school electrical system. In order to see the effect of AC, we need to slow down the frequency to the point where we can see the direction changing in the galvanometer or bulb.

13.3 Electronics

Diodes

13.3.1 Forward and Reverse Biased Diodes

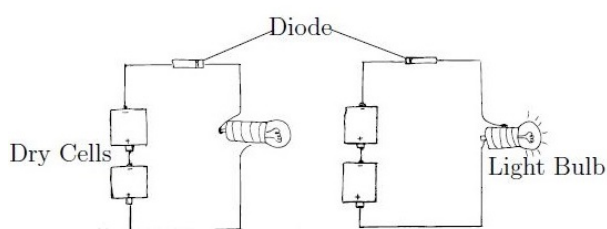

Materials: Diode, dry cell, bulb, connecting wires, nail, heat source or soldering iron

Setup: Remove a diode from a broken radio using a soldering iron or hot nail.

Procedure: Join the bulb in series with the P-N junction (diode). Connect the P-terminal of the junction to the positive terminal of the dry cell and the N-terminal of the junction to the negative terminal of the dry cell. Then reverse the terminals of the dry cell and observe any changes in the circuit.

Observations: The bulb lights in the first arrangement, indicating that current is flowing. If the terminals are reversed, the bulb will not light, indicating that no current is flowing.

Theory: The P-N junction allows current to flow only in one direction; current can flow from the P-terminal to the N-terminal, but not the other way. Current always flows from a positive terminal to a negative terminal.

Applications: Radios, phone chargers, etc.

Notes: A diode has two colours: white and black. The black side is the P-terminal and the white band is the N-terminal. Current will only flow from the black side to the white side.

13.3.2 Full-Wave Rectifier

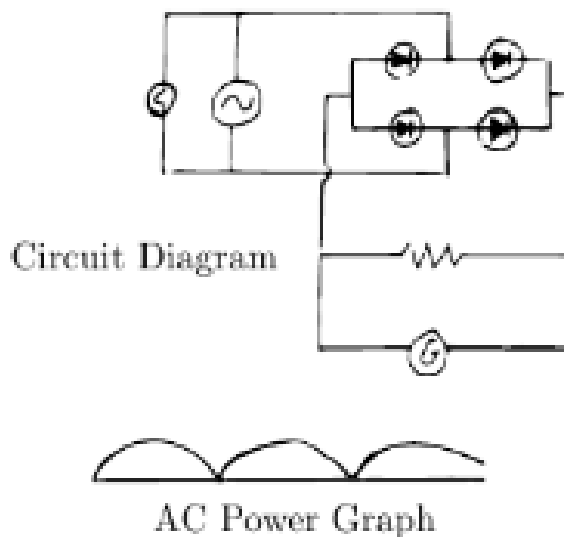

Materials: Low voltage AC power source (see [Inverter: Converting DC to AC](#)), connecting wires, 4 diodes, bulb, resistor, galvanometer, optional super glue

Hazards: Do not use the power from outlets in a house or school. These outlets put out a high voltage (220 V) which can kill you. Instead use a laboratory power supply or use D-cell batteries with an inverter as described above.

Setup: Connect two diodes in series with connecting wire by using super glue or any other means. Repeat for another pair of diodes. Connect these pairs in parallel so that current can flow through either pair but only in one direction. Connect also a resistor and galvanometer in parallel across the pairs of diodes. Attach the AC power source to the middle of each diode pair using connecting wires. Attach a bulb in parallel across the AC source.

Procedure: Connect the AC source directly to the galvanometer and observe the behaviour of the galvanometer. Connect the AC source to the full-wave rectifier and observe the relation of the galvanometer in relation to the bulb.

Observations: When the AC source is connected directly to the galvanometer, the galvanometer needle will jump one direction and then the other, showing the changing direction of current through the circuit. However, when the galvanometer is powered through the full-wave rectifier, it can be seen that the galvanometer only indicates one direction (positive or negative) and jumps quickly between

zero and its maximum value.

Theory: If observed closely with an AC source of low frequency, it can be seen that the bulb and galvanometer flicker at exactly the same rate. This is because the full-wave rectifier creates DC current which increases and decreases (but only in one direction) at the same frequency that the AC current is changing direction. As the bulb is following the AC current at a certain frequency, the galvanometer is being driven by the DC current at the same frequency of increasing and decreasing.

Notes: This activity is normally done with an oscilloscope, which clearly shows the waveform of the AC current and rectified current. However, the effect of the full-wave rectifier can be seen clearly if you are using the correct components.

First, the full-wave rectification can be compared to the half-wave rectification. If you connect the AC source to both a half-wave rectifier and a full-wave rectifier, each with a galvanometer, it can be seen that the full-wave rectifier causes the galvanometer to move at twice the speed of the half-wave rectifier.

Also, when a bulb is attached in parallel across the AC source while the galvanometer reads the current through the full-wave rectifier, it can be seen that the bulb and galvanometer flicker at the same rate, proving that the entire AC wave is being converted directly to DC rather than only half of the wave.

13.3.3 Half-Wave Rectifier

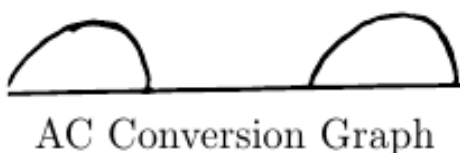
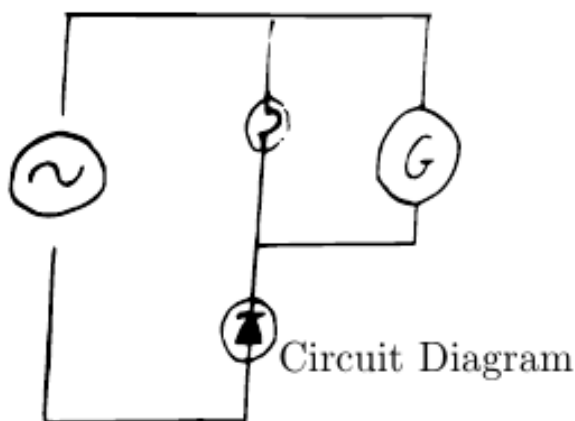

Materials: Low power AC power source (see [Inverter: Converting DC to AC](#)), diode, bulb, galvanometer, connecting wires

Hazards: Do not use the power from outlets in a house or school. These outlets put out a high voltage (220 V) which can kill you. Instead use a laboratory power supply or use D-cell batteries with an inverter as described above.

Setup: Connect the P-side of a diode (the black colour indicates P-type) to one of the connecting wires from the power source. Connect one of the terminals of the bulb to the N-side of the diode (a white band indicates N-type). Connect the other terminal of the bulb to the remaining connecting wire of the power source. You should now have a power source, diode and bulb all in series. Connect the galvanometer in parallel with the bulb.

Procedure: Turn on the power and watch the behavior of the galvanometer.

Observations: When AC power is connected to a galvanometer, it is seen that the current is changing direction quickly, causing the needle to jump back and forth. When the AC is passed through a half-wave rectifier, however, the current is only in one direction (positive or negative) and jumps between zero and the maximum value at half the speed that it did with AC current.

Theory: This is because the AC current is being cut in half through the rectifier and is allowed to move in only one direction. If using a bulb, it will be seen that the bulb flickers quickly with AC current, but only half as quickly with half-wave rectified current.

Notes: This activity is normally done with an oscilloscope, which shows the wave pattern of the AC current (it is a sine wave). If seen on the oscilloscope, the AC appears as a full sine wave, while the half-wave rectified current appears as only the positive or negative part of the sine wave (it looks like hills separated by long spaces).

A half-wave rectifier, rather than converting AC directly to DC, simply removes all current in one direction and allows all current in the other direction. In this way, the product is direct current, but only half of what was produced by the AC power source.

13.4 Elementary Astronomy

The Solar System

13.4.1 Student Solar System



Procedure: Place a chair at the centre of the football field of your school to represent the sun. Now ask 8 students to go around the chair in circles to represent the planets. The radius of each circle should correspond to the distance of the respective planet from the sun. For examples, using a scale of 1 cm representing 1 million km from the sun, then the radius of Mercury must be 58 cm, that of Venus 107 cm, earth 149 cm, and so on. (Of course, in this scale, the sun would be a ball of 2 cm diameter, the earth only a grain of sand).

Questions: What would the radii of the paths of Jupiter and Uranus be in this model?

Theory: They will be 7.8 m and 28.5 m respectively.

Planet	Distance in millions of km from sun
Mercury	58
Venus	107
Earth	149
Mars	227
Jupiter	773
Saturn	1418
Uranus	2853
Neptune	4469

Notes: Pluto is no longer considered a planet, but revolves the sun at a radius of 5866 km.

13.4.2 Solar System Mobile

Materials: Flour, water, balloons, mixing bowl, strips of newspaper or old papers, string, sticks

Setup: Blow up nine balloons, one for each of the 8 planets and sun. Make a **Papier Mâché** mixture with flour and water. Wet the paper strips in this mixture and apply to the balloons until you have a layer a couple papers-thick on each balloon. Leave each balloon slightly exposed at the bottom.

Procedure: When the papers are dried, pop the balloons inside. Use paint or marker pens to make the paper balls look like planets. Attach string and hang the planets in order around the sun.

Notes: Remember that the planets are all at different distance from the sun, but they are all in the same plane. For this reason, hang the planets at about the same height.

13.4.3 Model of Sun-Earth-Moon

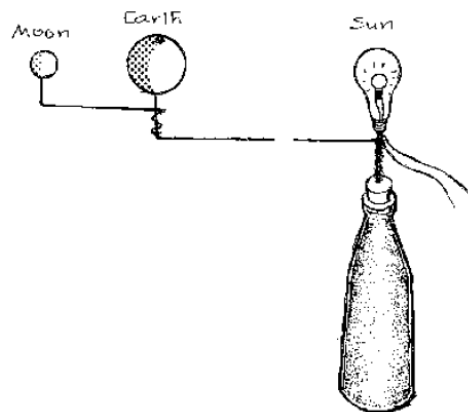

Materials: Seed, fruit, bulb, stiff wires, bottle, sand

Procedure: Pierce a seed and a small fruit with wires. Join a bulb to a bottle filled with sand using a wire. Join the three wires so that they allow rotation.

Observations: The seed, fruit and bulb represent the moon, earth and sun respectively. The bulb may be lit using a battery.

Theory: The model can be used to show the movement of the earth and moon around the sun and earth respectively. It can also show the eclipse of the moon and sun, when the earth shades the moon or the moon shades a part of the earth respectively.

Gravitational Force

13.4.4 Centripetal Force

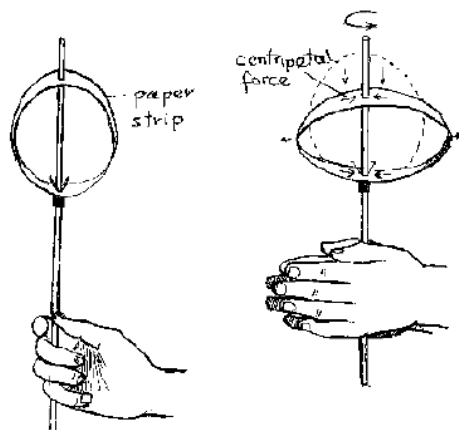
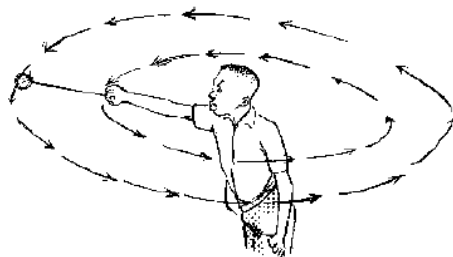

Materials: Ball or stone, thread

Procedure: Tie a ball or stone to a thread and whirl it around as shown.

Questions: What force keeps the stone on its circular track?

Theory: A force acts along the thread (which can be felt in your hand) called *centripetal force* which keeps the stone in its circular path. A centripetal force also acts on each planet to keep it on its circular path.

Notes: Due to its inertia a body will move along a straight path when *no* force acts on it. If the force of gravity between the planets and sun were suddenly turned off, they would drift out of their orbits in straight lines tangent to their orbits.

13.4.5 Bucket Swing

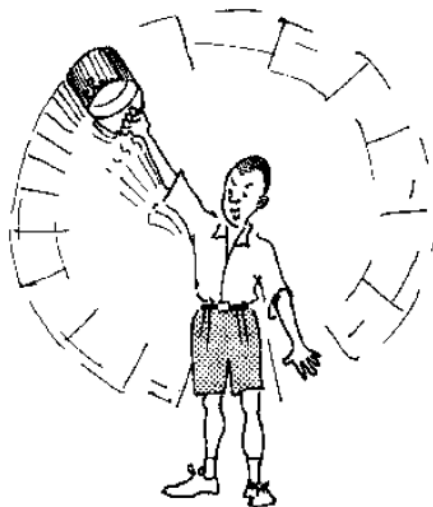

Materials: Bucket, water, rope

Procedure: Swing a bucket partially filled with water in vertical circles over your head by holding a rope.

Questions: What happens to the water inside?

Observations: When you swing the bucket with speed, the water remains in the bucket even when facing upside-down.

Theory: Centripetal force keeps the water forced against the bottom of the bucket, or away from the centre of its orbit. Similarly, there is a centripetal force between the planets and sun.

Constellations

13.4.6 Star Gazing

Procedure: Take the students out at night where there is little light from lamps and fires. Look for constellations, stars, planets and satellites. Discuss the reason for having constellations and the motion of the sky over the course of a night and a year.

Observations: Especially in rural areas, the stars and other celestial bodies are very clear. Depending on the time of year, different planets and constellations will be visible. The most obvious constellations are Orion, Ursa Major and the Southern Cross. The brightest star is Sirius. If the sky is clear then our galaxy, the Milky Way, is visible as a bright stripe across the sky.

Materials and Equipment

Local Materials List

In order to gain a thorough understanding of science, students must be able to make a connection between classroom learning and the outside world. The following is a list of locally available materials which may be used to substitute conventional materials and apparatus for various activities. These materials have the following advantages:

- They are readily available in the village or a nearby town;
- They are cheaper than conventional materials;
- They may safely substitute the conventional materials without fear of losing accuracy or understanding;
- They help students to draw a connection between science education and the world around them.

Imagination and innovativeness is encouraged on the part of the student and teacher to find other suitable local substitutions.

Below are common apparatus you might order from a laboratory supply company, and comments about which have good if not superior alternatives available in villages and towns. Given equal quality, it is generally better to use local materials, because these help connect classroom learning to students' lives.

The apparatus listed in this section are the following:

- | | | |
|-----------------------|----------------------------|------------------------------|
| 1. Alligator Clips | 18. Gloves | 35. Spring Balance |
| 2. Balance | 19. Goggles | 36. Springs |
| 3. Beakers | 20. Heat Source | 37. Stoppers |
| 4. Bulbs | 21. Iron Filings | 38. Stopwatches |
| 5. Bunsen Burner | 22. Masses | 39. Test Tubes |
| 6. Circuit Components | 23. Measuring Cylinder | 40. Test Tube Brush |
| 7. Containers | 24. Metre Rule | 41. Test Tube Holder / Tongs |
| 8. Deflagrating Spoon | 25. Microscope | 42. Test Tube Racks |
| 9. Delivery Tube | 26. Mirrors | 43. Tripod Stands |
| 10. Drawing Board | 27. Nichrome Wire | 44. Volumetric "Glass"ware |
| 11. Droppers | 28. Optical Pins | 45. Wash Bottle |
| 12. Electrodes | 29. Pipettes | 46. Water Bath |
| 13. Eureka Can | 30. Pulleys | 47. Weights |
| 14. Filter Paper | 31. Resistors | 48. Wire |
| 15. Flasks | 32. Retort Stand | 49. Wire Gauze |
| 16. Funnel | 33. Scale Pans | |
| 17. Glass blocks | 34. Slides and Cover Slips | |

How many experiments can be carried out with everyday items?

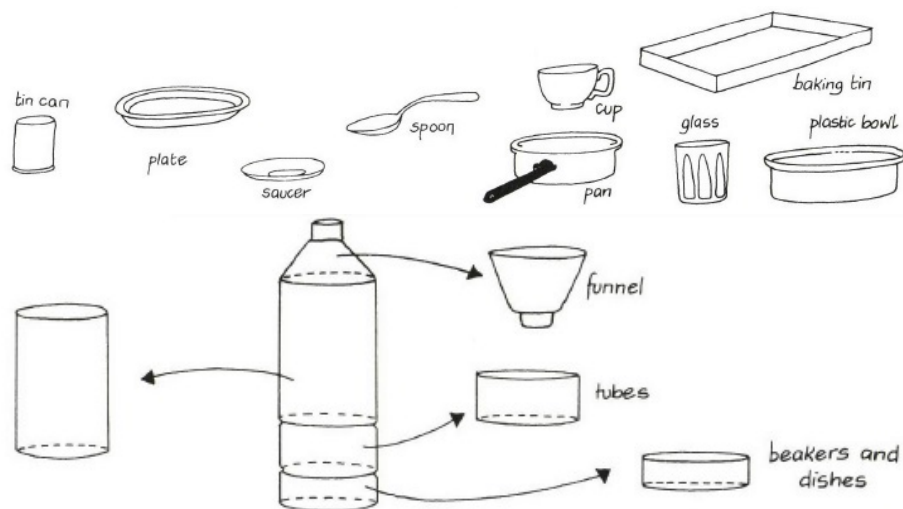

14.1 Alligator Clips

Use: Connecting electrical components

Materials: Clothespins, aluminum foil, glue

Procedure: Glue aluminum foil around the clamping tips of a clothespin.

14.2 Balance

Use: Measuring mass

Materials: Ruler or wooden bar 30 cm × 2 cm, nails, razor/knife, string/wire, pen, 2 Scale Pans

Procedure: Find the balancing point of the ruler/wood block and mark it with a pen. Use a heated nail to make a hole through this point. Make notches at 5 cm intervals on either side of the center hole using a razor/knife to suspend scale pans. Use a string/wire tied through the center hole to suspend the balance.

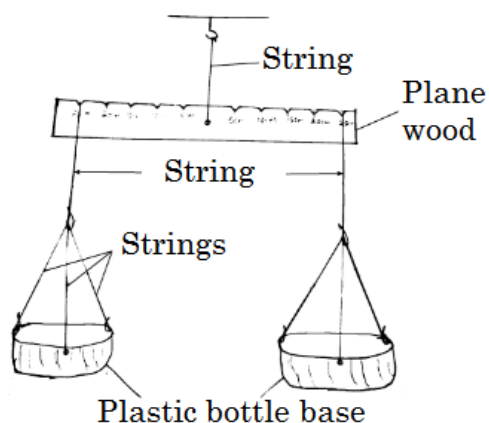

14.3 Beakers

Use: To hold liquids, to heat liquids

Materials: Water bottles, jam jars, metal cans, knife/razor

Procedure: Take empty plastic bottles of different sizes. Cut them in half. The base can be used as a beaker. Jam jars made of glass, cut off metal cans and aluminum pots may be used when heating.

Safety: Glass containers may shatter if heated too much. Use standard laboratory equipment if extreme heating is needed.

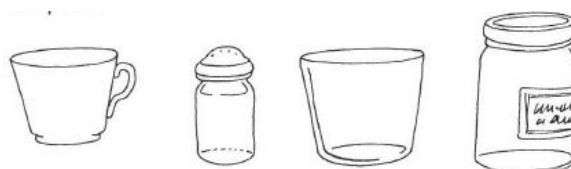

14.4 Bulbs

Use: Electrical circuits, diodes

Materials: Broken phone chargers, flashlights, other electronic devices

Procedure: Look for LEDs from broken items at hardware stores, local technicians, or small shops.

14.5 Bunsen Burner

See [Heat Source](#) (p. 132).

14.6 Circuit Components

Use: Building simple circuits, Ohm's Law, amplifier, wave rectifiers

Materials: Broken radio, computer, stereo, other electrical devices

Procedure: Remove resistors, capacitors, transistors, diodes, motors, wires, transformers, inductors, rheostats, pulleys, gears, battery holders, switches, speakers and other components from the devices. Capacitors tend to state their capacitance in microFarads on their bodies.

14.7 Containers

Use: Measuring large volumes (100 mL – 2 L) of solution, titration, storage

Materials: Plastic water bottles, jars, tin cans

Procedure: Identify the volume of useful marks on the bottles and combine to measure accurate volumes.

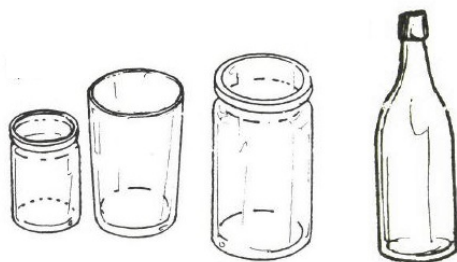

14.8 Deflagrating Spoon

Use: For heating chemicals to observe melting, decomposition, or other changes on heating

Materials: Metal spoons, galvanised wire, soda bottle cap

Procedure: Bend 30 cm of galvanised wire as shown. The wire should hold the bottle cap firmly.

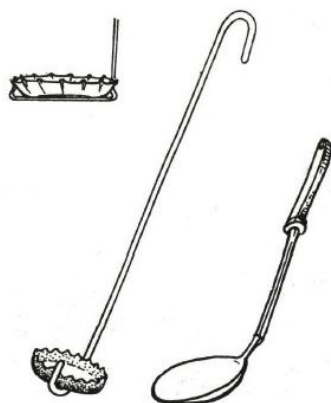

14.9 Delivery Tube

Use: Movement and collection of gases, capillary tubes, hydraulic press

Materials: Straws, pen tubes, IV tubing (giving sets) from a pharmacy, bicycle tubing

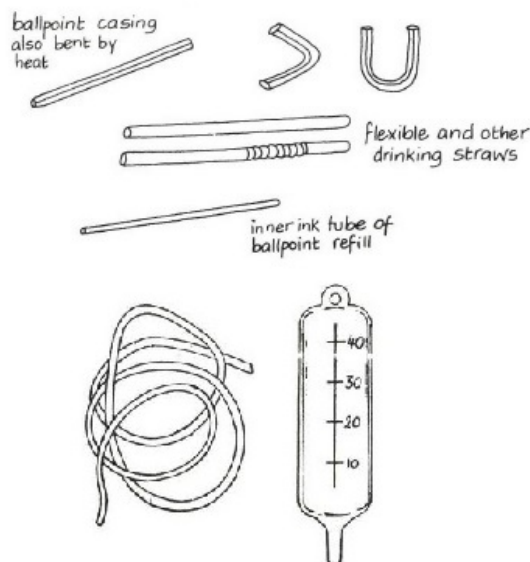

14.10 Drawing Board

Use: Dissection, reflection, refraction of light

Materials: Thick cardboard

14.11 Droppers

Use: To transfer small amounts of liquid

Materials: 2 mL syringes, straws

Procedure: Take a syringe. Remove the needle to use as a dropper. Or insert a straw into a liquid and then plug the free end with a finger to remove a small amount and use as a dropper.

14.12 Electrodes

Use: Electrolysis

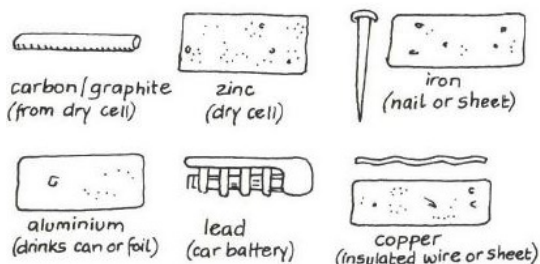

14.12.1 Graphite

Materials: Old dry cell batteries

Procedure: Gently smash an old battery (D size) with a rock and pull out the electrode with pliers. DO NOT do this with alkaline batteries (most AA size) as they contain caustic liquids.

14.12.2 Zinc

Materials: New dry cell batteries

Procedure: Carefully open up a NEW dry cell (D size) battery by peeling back the steel shell and slicing the plastic inside. You should find a cylindrical shell of zinc metal. Empty out the black powder inside (manganese dioxide mixed with zinc chloride and ammonium chloride; wash your hands after) and keep the graphite electrode for another day. The zinc shell should then be cut into strips, scraped clean, and boiled in water or washed with soap to remove any residual chemicals that might affect your experiment.

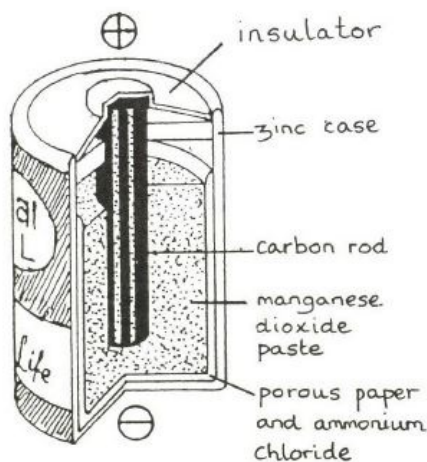

14.12.3 Iron

Materials: Ungalvanized nails from a hardware store

14.12.4 Copper

Materials: Thick wire stripped of its insulation, also from a hardware store. Note that copper earthing rods have only a thin surface layer of copper these days.

14.13 Eureka Can

Use: To measure volume of an irregular object, Archimedes' Principle, Law of Flotation

Materials: Plastic bottle, knife, Optional: super glue, straw, nail, candle

Procedure: Cut the top off of a 500 mL plastic bottle. Then cut a small strip at the top (1 cm wide by 3 cm long) and fold down to make a spout. Alternatively, heat a nail using a candle and poke a hole near the top of a cut off bottle. Super glue a straw so that it fits securely in the hole without leaking.

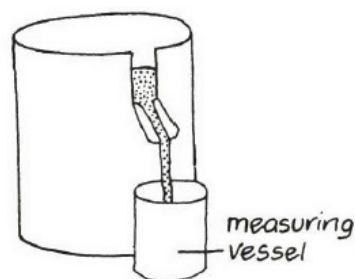

14.14 Filter Paper

Use: Filtration, separating mixtures, solutions

Materials: Cement bag paper, toilet paper, cloth

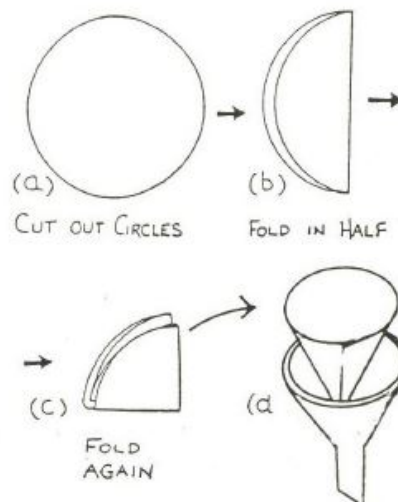

14.15 Flasks

Use: Titrations, mixing solutions

Materials: Clean used liquor bottles, small water bottles

Procedure: When using these flasks for titrations, students must practice swirling enough that the solution remains well mixed.

Safety: When heating glass liquor bottles, make sure the cap is off.

14.16 Funnel

Use: To guide liquid or powder into a small opening

Materials: Empty water bottles, knife

Procedure: Take an empty water bottle and remove the cap. Cut it in half. The upper part of the bottle can be used as a funnel.

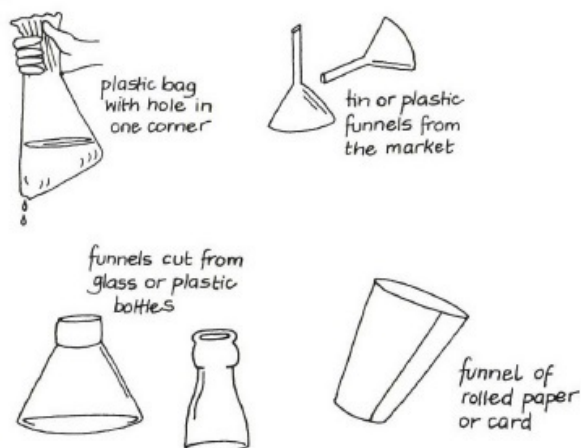

14.17 Glass blocks

Use: Refraction of light

Materials: 8 mm - 15 mm slabs of glass

Procedure: Have a craftsman make rectangular pieces of glass with beveled edges, so students do not cut themselves. Glass blocks from a lab supply company are generally 15 mm thick. 8 mm and 10 mm glass is relatively common in towns. 12 mm and thicker glass exists though is even more difficult to find. Stack several pieces of thinner glass together and turn them on their edge.

14.18 Gloves

14.18.1 Latex gloves

Use: First aid, when one has open cuts on hands, handling specimens. They are worthless to the chemist because they make the hands less agile and give the user a false sense of security.

Safety: Concentrated acids and organic chemicals burn straight through latex.

14.18.2 Thick gloves

Use: For working with organic solvents. Remember that the most dangerous organic solvents (benzene, carbon tetrachloride) should never be used in a school, with or without gloves.

Materials: Thick rubber gloves from village industry supply companies and some hardware stores

Safety: In general, avoid using chemicals that would make you want to wear gloves.

14.19 Goggles

Use: Handling concentrated acids

Materials: 1.5 L plastic water bottles, cardboard, sunglasses

Procedure: Cut a strip of plastic from a water bottle. Attach around your head with string or by using stiff cardboard as a frame. Goggles do not need to be impact resistant – they just need to stand between hazardous chemicals and your eyes.



14.20 Heat Source

Use: Heating substances

Materials: Candles, kerosene stoves, charcoal burners, Motopoa (alcohol infused heavy oil), butane lighters, spirit burners, metal can, bottle caps. Motopoa provides the best compromise heat source – it is the easiest to use and safest heat source with locally available burners.

Procedure: Cut a metal can in half or use a bottle cap and add a small amount of Motopoa.

Safety: Always have available fire-fighting equipment that you know how to use. Remember that to put out a Bunsen burner safely, you need to turn off the gas.

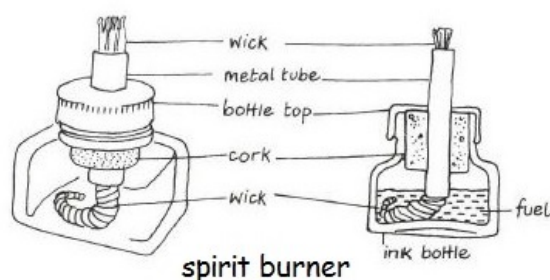
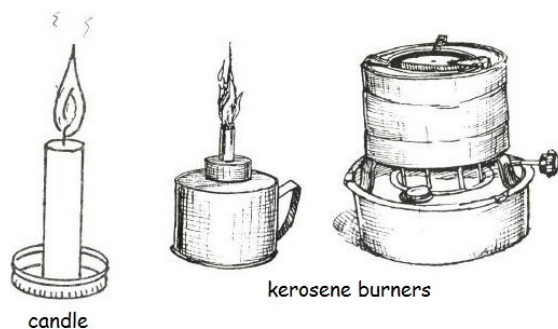

14.20.1 Heating Solutions

The ideal heat source has a high heat rate (Joules transferred per second), little smoke, and cheap fuel, i.e. Motopoa. A charcoal stove satisfies all of these but takes time to light and requires relatively frequent re-fueling. Kerosene stoves have excellent heat rates but are smoky.

14.20.2 Heating Solids

The ideal heat source has a high temperature and no smoke, i.e. a Bunsen burner. For heating small objects for a short time (no more than 10-20 seconds), a butane lighter provides a very high temperature. Motopoa will provide a flame of satisfactory temperature for as long as necessary.

14.20.3 Flame Tests

The ideal heat source has a high temperature and produces a non-luminous flame, i.e. a Bunsen burner. Motopoa is next best hot and non-luminous. Spirit burners produce a non-luminous flame at much greater cost, unless methylated spirits are used as fuel in which case the flame is much cooler. A butane lighter produces a very hot flame of sufficient size and time for flame tests although the non-luminous region is small. Kerosene stoves will work for some salts.

14.21 Iron Filings

Use: To map magnetic fields

Materials: Steel wool / Iron wool used for cleaning pots

Procedure: Rub some steel wool between your thumb and fingers. The small pieces that fall are iron filings. Collect them in a matchbox or other container to use again.

14.22 Masses

See [Weights](#) (p. 137).

14.23 Measuring Cylinder

Use: Measuring volume

Materials: Plastic bottles of different sizes, syringes (10 mL - 50 mL), fluorescent light tubes, marker pen, ruler, bucket of water

Procedure: Using the syringe, transfer a known volume of water from the bucket to the empty bottle. Use the marker pen to mark the level of water on the bottle. Repeat for a range of volumes, using a ruler to complete the scale.

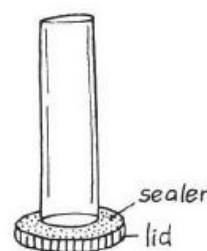

14.24 Metre Rule

Use: Measuring length

Materials: Slabs of wood, ceiling board, permanent pen

Procedure: Buy one, take it and a permanent pen to a carpenter, and leave with twenty. Measure each new one to the original rule to prevent compounding errors.

14.25 Microscope

See [Low Tech Microscopy](#) (p. 139).

14.26 Mirrors

14.26.1 Plane Mirrors

Use: Microscope, Laws of Reflection

Materials: piece of thin glass, kibatari, super glue, small wooden blocks

Optional: Small pieces of mirror glass are cheap or free at a glass cutter's shop

Procedure: Light the kibatari so that it creates a lot of smoke. Pass one side of the glass repeatedly over the kibatari until that side is totally black. The other side acts as a mirror. Super glue to small wooden blocks to stand upright.

14.26.2 Curved Mirrors

Use: Curved mirror practicals

Materials: Spoons

Procedure: Inside surface is a concave mirror; back surface is a convex mirror.



14.27 Nichrome Wire

For flame tests in chemistry, you can use a steel wire thoroughly scraped clean with iron or steel wool. For physics experiments, see [Wire](#) (p. 138).

14.28 Optical Pins

Use: Compass needles, making holes, dissection, mirror practicals

Materials: Office pins, sewing needles, needles from syringes

14.29 Pipettes

Use: Transferring small amounts of liquid

Materials: Disposable plastic syringes (1, 2, 5, 10, 20, 25, 30 and 50 mL sizes)

Procedure: Suck first 1 mL of air and then put the syringe into the solution to suck up the liquid. There should be a flat meniscus under the layer of air.

Safety: Avoid standard pipettes to eliminate danger of mouth pipetting.

14.30 Pulleys

Use: Simple machines

Materials: Bent nail, twisted wire, thread reel, water bottle, string, coat hanger

Procedure: Cut off the top of a water bottle just below the lip where the top screws on. Run string or stiff wire through the centre to hang from a table or chair.

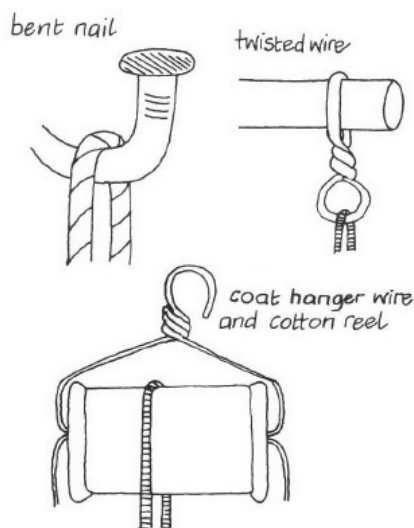

14.31 Resistors

Use: Electrical components

Materials: Old radios, circuit boards, soldering iron

Procedure: Remove resistors from old radios and circuit boards by melting the solder with a soldering iron or a stiff wire heated by a charcoal stove. If you need to know the ohms, the resistors tell you. Each has four strips (five if there is a quality band) and should be read with the silver or gold strip for tolerance on the right. Each color corresponds to a number:

black = 0	yellow = 4	violet = 7
brown = 1	green = 5	gray = 8
red = 2	blue = 6	white = 9
orange = 3		

and additionally for the third stripe: gold = -1 and silver = -2.

The first two numbers should be taken as a two digit number, so green-violet would be 57, red-black 20, etc. The third number should be taken as the power of ten (a 10^n term), so red-orange-yellow would be $23 \times 10^4 = 230000$, red-brown-black would be $21 \times 10^0 = 21$ and blue-gray-silver would be $68 \times 10^{-2} = 0.68$. The unit is always ohms. The fourth and possibly fifth bands may be ignored.

14.32 Retort Stand

Use: To hold springs, burettes, pendulums or other objects

Materials: Filled 1.5 L water bottle, straight bamboo stick, tape, marker

Procedure: Tape the bamboo stick across the top of the water bottle so that it reaches out 20 cm to one side. Attach a small clamp if required or hang the object directly from the bamboo stick.

Alternatively, place a 1 cm piece of reinforcing rod in a paint can full of wet cement and let it dry. Then attach a boss head and clamp.

14.33 Scale Pans

Use: Beam balance

Materials: Plastic bottle, cardboard box, string

Procedure: Cut off the bottom of a plastic bottle or cardboard box. Poke 3 or more holes near the top and tie string through each hole. Join strings and tie at the top to hang from a single point.

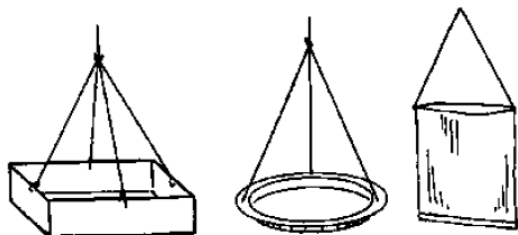

14.34 Slides and Cover Slips

Use: Microscopy

Materials: Small pieces of glass, stiff plastic

Procedure: Small piece of glass provides a slide for mounting the specimen. Cover slips can be made from thin (but stiff) transparent plastic from display packing or bottles. Cut into small squares or circles.

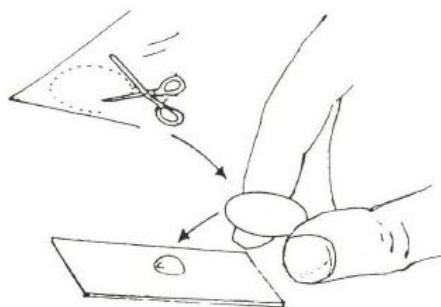

14.35 Spring Balance

Use: To measure force applied on an object

Materials: Strip of cardboard, rubber band, 2 paper clips, staple pin, pen

Procedure: Cut a rubber band and fix one end to the top of a cardboard strip using a staple pin. (A stronger rubber band allows for a greater range of forces to measure.) Attach one paper clip near the top as a pointer. Attach the other paper clip as a hook at the bottom of the rubber band. Calibrate the spring balance using known masses. Write the equivalent force in Newtons on the cardboard. (A 1 g mass has a weight of 0.01 N, 100 g has a weight of 1 N, etc.)

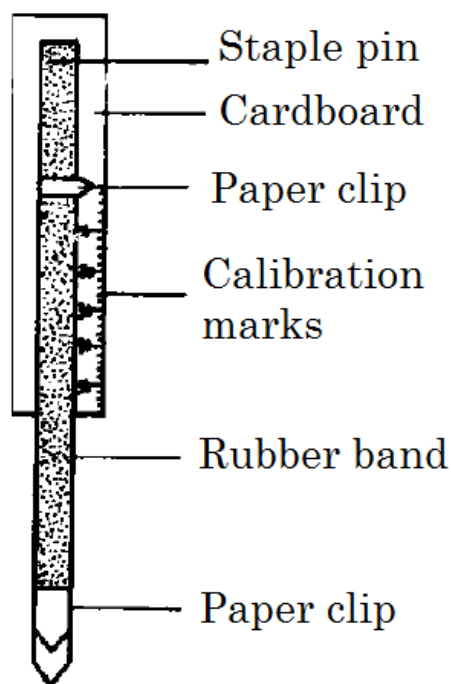

14.36 Springs

Use: Hooke's Law, potential energy, work, spring balance

Materials: Springs from hardware stores, bike stores, junk merchants in markets, window blinds; stiff wire; rubber bands; strips of elastic

Procedure: Remove plastic covering if necessary and cut to a desired length (5 cm). Alternatively wind a stiff wire around a marker pen or use rubber bands or elastic from a local tailor.

14.37 Stoppers

Use: To cover the mouth of a bottle, hold a capillary tube

Materials: Rubber from old tires or sandals, cork, plastic bottle cap, pen tube, super glue

Procedure: Cut a circular piece of rubber. If the stopper is being used to hold a capillary tube, a hole can be melted in a plastic cap or rubber stopper. Alternatively, super glue a pen tube to a plastic bottle cap and connect to rubber tubing.



14.38 Stopwatches

Use: Simple pendulum, velocity, acceleration

Materials: Athletic and laboratory stopwatches from markets, digital wristwatches

14.39 Test Tubes

14.39.1 Plastic Test Tubes

Use: To heat materials without a direct flame, to combine solutions

Materials: 10 mL syringes, matches

Procedure: Remove the needle and plunger from 10 mL syringes. Heat the end of the shell with a match until it melts. Press the molten end against a flat surface (like the end of the plunger) to fuse it closed. If the tube leaks, fuse it again. Test tubes made this way may be heated in a water bath up to boiling, hot enough for most experiments.



14.39.2 For Thermal Decomposition

See [Deflagrating Spoon](#) (p. 130).

14.40 Test Tube Brush

Use: Cleaning test tubes

Materials: Sisal, wire

Procedure: Twist the wire around the sisal as shown or put a little sand in the test tube as an abrasive.

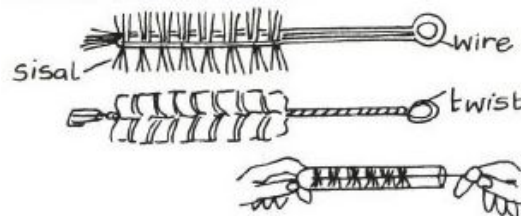

14.41 Test Tube Holder / Tongs

Use: To handle test tubes

Materials: Wooden clothespins, stiff wire, strip of paper or cloth

Procedure: Use clothespins or stiff wire for prolonged heating, or strips of paper or cloth for short-term heating.

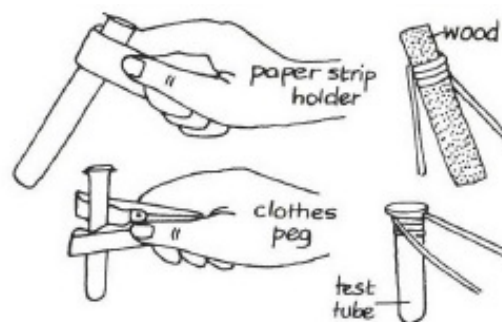

14.42 Test Tube Racks

Use: To hold test tubes vertically in place

Materials: Wire grid from local gardening store, styrofoam block, plastic bottle, sand, knife

Procedure: Fold a sheet of wire grid to make a table; punch holes in a piece of styrofoam; cut a plastic bottle in half and fill it with sand to increase stability. Or cut a plastic bottle along its vertical axis and rest the two cut edges on a flat surface. Cut holes into it for the test tubes.

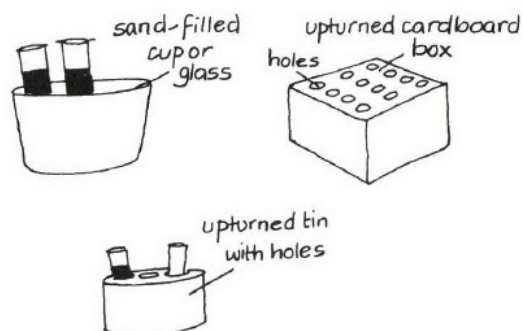

14.43 Tripod Stands

Use: For supporting containers above heat sources, for elevating items

Materials: Stiff wire, metal rods, tin can

Procedure: Join bent pieces of thick wire together. Or cut the sides of a tin can to leave 3 legs.

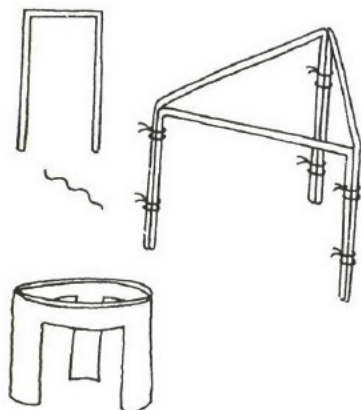

14.44 Volumetric “Glass” ware

See [Containers](#) (p. 130).

14.45 Wash Bottle

Use: Washing hands after experiments

Materials: Water bottle, detergent, needle

Procedure: Put a hole in the cap of a water bottle using a syringe needle.

14.46 Water Bath

Use: To heat substances without using a direct flame

Materials: [Heat Source](#), water, cooking pot

Procedure: Bring water to a boil in a small aluminum pot, then place the test tubes in the water to heat the substance inside the test tube. Prevent test tubes from falling over by clamping with clothespins or placing parallel wires across the container.

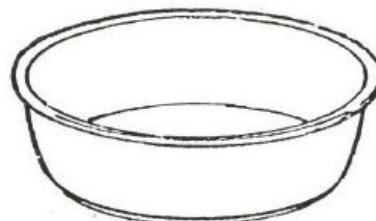
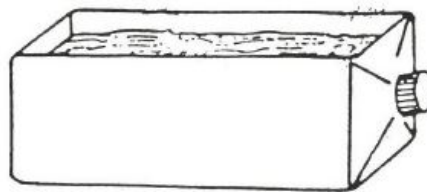

14.47 Weights

14.47.1 Crude Weights

Use: Concept of units, mass, weight

Materials: Batteries, coins, glass marbles from town, etc.

Procedure: Use objects of unknown mass to create new units and impart the concept of unit measure.

14.47.2 Adding Weight in Known Intervals

Use: Hooke’s Law practical

Materials: Water bottles, syringe

Procedure: Consider “zero added mass” the displacement of the pan with an empty water bottle. Then add masses of water in g equal to their volumes in mL (e.g. 50 mL = 50 g).

14.47.3 Precise Weights

Materials: Plastic bags, sand, stones, 250 mL water bottles (all identical), tape, pen

Procedure: Use a beam balance and known masses at a market or nearby school to measure exact masses of bags of sand or stones. Use a marker pen to mark the masses on the bags.

If using water, use a beam balance from a nearby school to measure the exact mass of an empty water bottle. Add a volume of water in mL equal to the mass in g needed to reach a desired total mass. (The density of water is 1.0 g/mL.) This can be done precisely by using a plastic syringe. Label the bottle with tape and a pen.

14.48 Wire

14.48.1 Connecting Wires

Use: Connecting circuit components, current electricity

Materials: Speaker wire, knife

Procedure: Speaker wire can be found at any hardware store or taken from old appliances - the pairs of colored wires braided together. Strip using a knife, scissors or a wire stripper.



14.48.2 Specific Gauge Wire

Use: Electrical components, motors, transformers, simple generators

Materials: Copper wire without plastic covering (transformer wire), knife/scissors, matches

Procedure: Scrape or burn off the insulating varnish at any points you wish to make electrical contact. These wires come in a variety of diameters (gauges). A useful chart for converting diameter to gauge may be found at <http://www.dave-cushman.net/elect/wiregauge.html>. If the wire is sold by weight, you can find the length if you know the diameter - the density of copper metal at room temperature is 8.94 g/cm^3 . For example, with 0.375 mm wire, 250 g is about 63 metres.

14.49 Wire Gauze

Use: Placing objects over heat

Materials: Tin can lid

Procedure: Poke holes in a tin can lid.

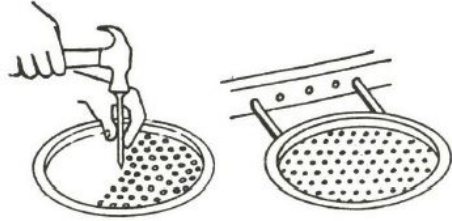

Low Tech Microscopy

Microscopes are powerful tools for teaching biology, and many of their benefits are hard to replace with local fabrications. However, simple materials can be used to achieve sufficient magnification to greatly expand students' understanding of the very small. They may view up close the anatomy of insects and even see cells.

15.1 Water as a lens

Water refracts light much the way glass does; a water drop with perfect curvature can make a powerful lens. A simple magnifier can be made by twisting a piece of wire around a nail and dipping the loop briefly into some water. Students can observe the optical properties of the trapped drop of water.

15.2 Perfect circles

Better imaging can be had if the drop is more perfect in shape – the asymmetry of the wire twisting distorts the image. Search for a piece of thin but stiff plastic – water bottles work well. Cut a small piece of this plastic, perhaps 1 × 2 centimeters. Near one end, make a hole, the more perfect the better. The best hole-cutting tool is a paper hole punch, available in many schools. With care, fine scissors or a pen knife will suffice; remove all burrs.

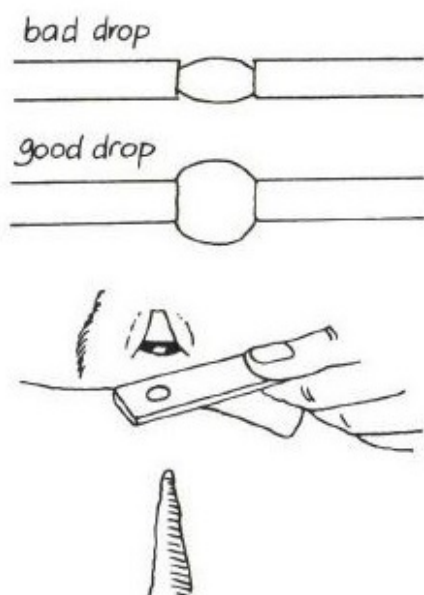

15.3 Slides

A slide and even cover slip may be made from the same plastic water bottles, although being hydrophobic they will not have the same properties of glass when making wet mounts. Improvise a method for securing the punctured plastic over the slide; ideally the vertical spacing can be closely adjusted to focus.

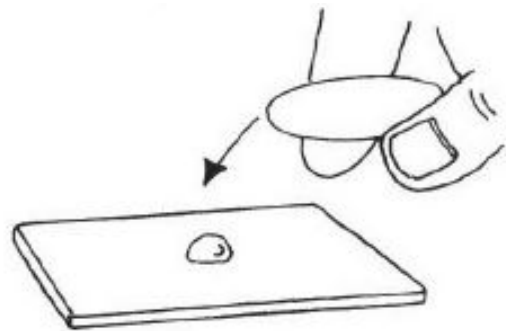

15.4 Backlighting

On a bright day, there may not be any need for additional lighting, but in most classrooms the image will be too dim to be easily seen. The sun is a powerful light source, though not always convenient. Flashlights are generally inexpensive and available; many cell phones have one built in the end. To angle the light into the slide, find either a piece of mirror glass, wrinkle-free aluminum foil, the metalized side of a biscuit wrapper, etc.

Experiment with a variety of designs to see what works best given the materials available to your school. If you use a slide of onion cells stained with iodine solution, your students should be able to see cell walls and nuclei.

15.5 Simple Microscopes and Magnifiers

the eye should be placed as near as possible to the lens when viewing.

15.5.1 Clear-Container Magnifiers

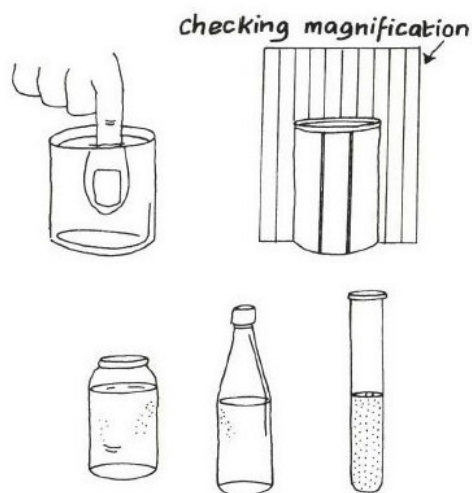

Any of these containers filled with water will make good magnifiers.

15.5.2 Simple Microscope

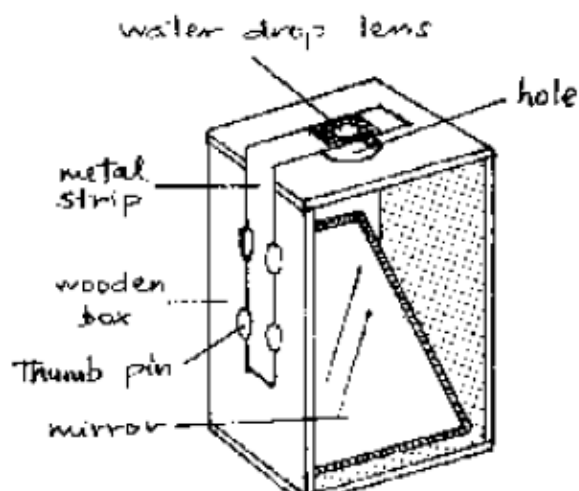

Construct a small wooden box from plywood as shown (or use a small cardboard carton such as a light bulb box). Make a round hole of 2 cm diameter, at the top. Fit a small mirror (glass or polished metal) in the box, angled to reflect light up through the hole. Make a small hole (about 6 mm) in a strip of metal. Remove the round top from a pen-torch bulb and secure it in the strip using adhesive tape. Carefully cut off the tape where it may cover the lens. Bend the strip, then fix it to the side of the box, so that it can be moved up and down. Drawing pins or nails could be used for this. The object is focused by moving this strip. Note

15.5.3 Simple Compound Microscope

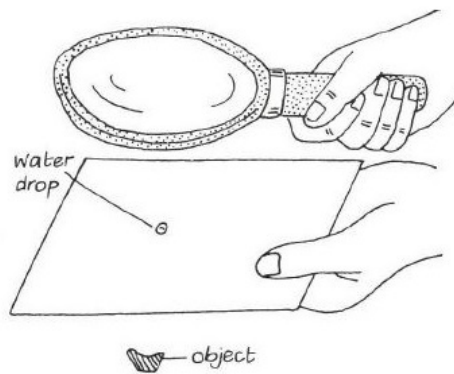

- Using 2 lenses together allows much greater magnification.
- Use a hand lens to make a water drop into a more powerful magnifier.
- Try using a hand lens with a lens from a torch bulb to make another simple compound microscope.

15.5.4 Card Bridge Microscope

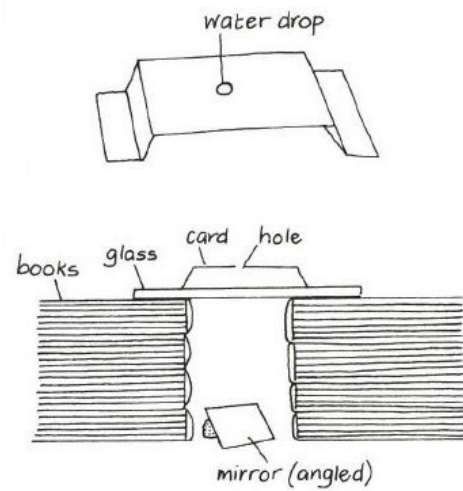

- Place a water drop in the card 'bridge'.
- Place this on a sheet of glass as shown.
- Place the object you are looking at on the glass. This arrangement is most suitable for thin items, e.g. sections of leaves.
- Experiment with the angle of the mirror so that light shines up through the specimen.
- Use this arrangement with a hand lens to produce a compound microscope.

Storage of Materials

16.1 The Science Box

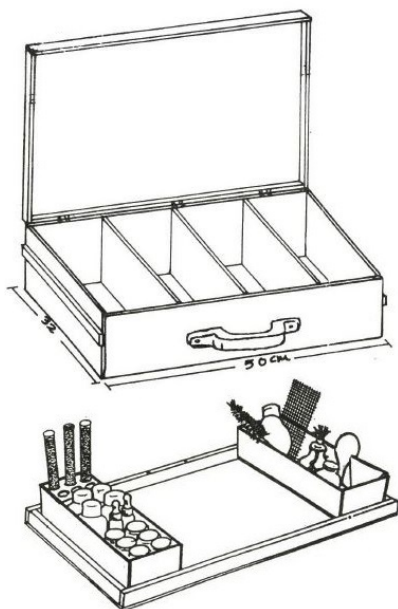

- Use a metal storage trunk to organize all of your new, locally-made science equipment.
- Metal or cardboard sheets can be used as dividers. Tape firmly in place.
- Use the lid as a science tray for safely and easily moving liquids and chemicals.

16.2 Card and Picture Boxes

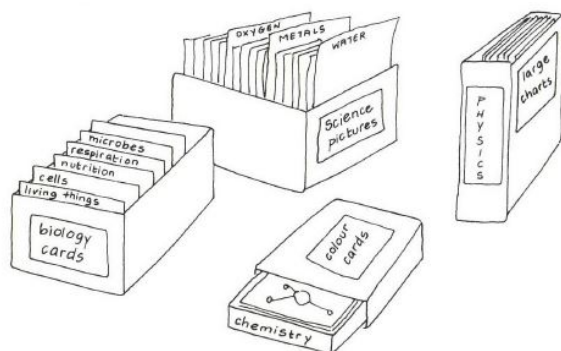

- Cards and pictures can be stored in all sorts of boxes. Store according to syllabus topic or alphabetically.
- Dividers and compartments can be made from cardboard.

16.3 Matchbox Drawers

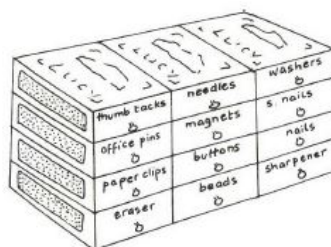

- Drawers to store small items can be made from matchboxes glued together as shown.
- Small pieces of string, wire or buttons can be used as handles.

16.4 Dividing Boxes

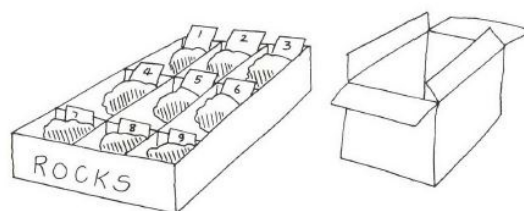

- Cut down the sides of boxes for displays.
- Samples can be sorted, then displayed or stored in cardboard boxes as shown.
- The flaps from the top of the box may be cut off and used as dividers for the same box.

16.5 Envelopes and Bags

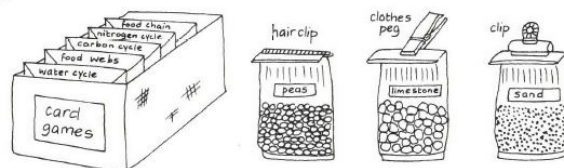

- Envelopes and bags of different sizes can be used for storage. Clearly label all containers.

Pastes and Modeling Materials

17.1 Papier Mâché



- Soak pieces of paper or card in water for half a day.
- Mash, grind, stir or pound the mix to a smooth fine pulp.
- Squeeze or press out excess water.
- Mix in a little flour paste and work the material into a sticky modeling consistency.

17.2 Papier Mâché Layering

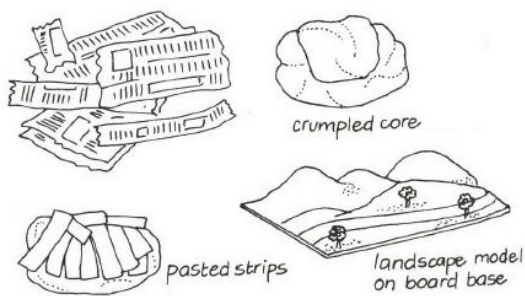

- Soak small pieces, or narrow strips, of newspaper in paste.
- Use crumpled newspaper as a core or skeleton for the model.
- Build up the model in layers of strips and pieces.
- After drying, sandpaper smooth and paint or varnish.

17.3 Modeling Clay



- Dig out or collect your clay. Seek local advice on where to find suitable deposits.
- Add water and stir to a creamy consistency.
- Filter through cloth or a sieve.
- Allow the filtered material to settle.
- Decant excess water.
- Dry the filtered material on newspaper until it becomes a powder.
- Mix in glycerine to give a plastic texture.
- Knead well and add Vaseline to soften if necessary.
- Adding paste (see page 118) to the clay helps stop it cracking as it dries.

17.4 Paste and Sand Cement

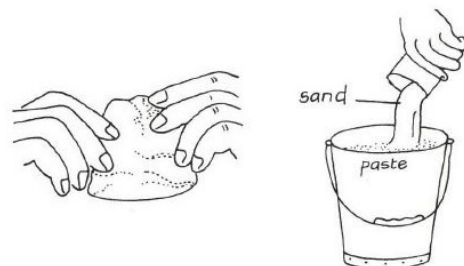

- Mix evenly together dry sand and flour paste or commercial glue.
- The wet cement moulds very easily and dries hard.

17.5 Flour Paste



- Sift flour to remove lumps. Maize, wheat and cassava flours are all suitable.
- Mix the flour with water a little at a time to avoid lumps. It should be the consistency of thin cream.
- Cook the mixture gently until it thickens. Keep stirring to ensure the paste remains smooth and of even texture.
- Allow the paste to cool.
- Add insecticide to the paste if needed.
- Store in a clearly labeled container with a good lid, preferably in a cool place.
- Cold method paste is made by simply stirring sifted flour into water.

17.6 Casein Glue

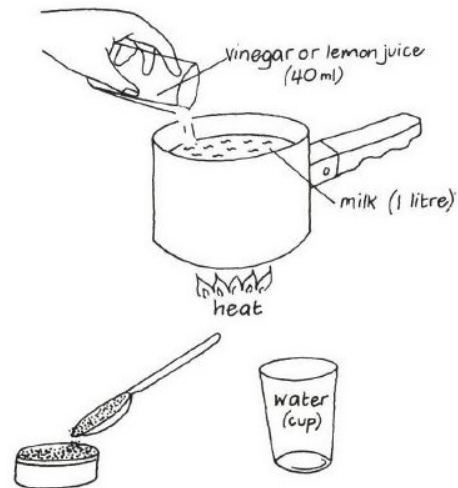

- Mix milk with vinegar or lemon juice. Add just enough vinegar or lemon juice to curdle the milk. The amounts will vary according to the type of milk used.
- Heat while stirring continuously. Soft lumps will form.
- Strain out the lumps using a cloth.
- Add a teaspoon of sodium hydrogen carbonate (bicarbonate of soda) to the lumps and mix with a little water to produce casein glue.

Activity Template

The Shika members know that there is always room for new and improved activities, and it is much appreciated, so below is a template for contributing activities to the current manuals.

Please fill out the table below and send it to **shika.mikono.tz@gmail.com**. Not every cell has to be filled in - some cells may not be applicable to each activity. Examples of how the activities should look can be found throughout this manual. Corresponding pictures can also be sent to the above email address.

Section	Fill this in...	Comments
Title		The title of your activity
Form, Topic, and Subtopic		The form, topic, and subtopic that this activity applies to in the syllabus
Materials		List all the materials needed to complete the activity
Setup		What to do to prepare the activity
Procedure		How to carry out the actual activity
Hazards		If there is any danger involved with the activity, state it here and what to do if it happens
Questions		Possible follow-up or discussion questions
Observations		State what is observed as a result of the activity
Theory		Background information and theory behind the activity
Applications		Any real-life applications or uses of the activity
Notes		Any other information that should be stated about the activity